

This **CHARTER** is entered into by and between **ST. ALOYSIUS** (“**Sponsor**”) and **The Edge Academy** (“**School Governing Authority**”), the governing board of a new start-up Ohio public community school established as a public benefit corporation under Ohio Revised Code (R.C.) Chapter 1702.

WHEREAS, R.C. Chapter 3314 permits Ohio public community schools; and

WHEREAS, **St. Aloysius** is an authorized **Sponsor** under R.C. Chapter 3314; and

WHEREAS, the **School Governing Authority** is an Ohio public benefit corporation with its corporate principal place of business located at **92 North Union Street, Akron, Ohio 44304** (“**School**”) in **Summit County**, Ohio; and

WHEREAS, the **School** is located in the **Akron City School District**; and

WHEREAS, the **School Governing Authority** wishes to fully state or restate its agreement to operate an Ohio community school;

NOW THEREFORE, the **School Governing Authority** and the **Sponsor** enter into this Charter pursuant to the following terms and conditions. All Attachments and Recitals to this Charter are incorporated by reference and made a part of this Charter.

ARTICLE I

Purpose

- 1.1 **Purpose.** This Charter authorizes the operation of the **School** pursuant to R.C. Chapter 3314. Such school shall be a public school, independent of any School District and is part of the State of Ohio Program of Education. Pursuant to R.C. Section 3314.01, the **School Governing Authority** may sue and be sued, acquire facilities as needed, and charter for services necessary for the operation of the **School**. The **School Governing Authority** may carry out any act and ensure the performance of any function that is in compliance with the Ohio Constitution, R.C. Chapter 3314, other statutes applicable to community schools and the terms of this Charter. The **School Governing Authority** covenants and agrees to Sections 1.2 through 1.6 below.
- 1.2 **Non-Profit Corporation.** The **School** is established and operated as a non-profit corporation under R.C. Chapter 1702 if established prior to April 8, 2003. The **School Governing Authority** shall maintain in good standing the **School’s** status as a non-profit corporation. The **School Governing Authority** shall hold all rights to the name of the **School** and any trade names or fictitious names.
- 1.3 **Public Benefit Corporation.** The **School Governing Authority** must be an Ohio Public Benefit Corporation under R.C. 1702.01(P), if formed after April of 2003. Attached as **Attachment 1.3** are the Certificate of Incorporation, Articles of Incorporation, and Code of Regulations. Any changes or updates in any of these documents must be reported in

writing to the **Sponsor** within five (5) business days of the effective date of such changes, along with a copy of all documentation and filings.

For schools beginning operation after July 1, 2020 than December 31 of the current year, the **School Governing Authority** shall apply to qualify as a federal tax exempt entity under Section 501(c)(3) of the Internal Revenue Code. The **School Governing Authority** shall submit a copy of the application as submitted to the IRS the **Sponsor** within five (5) business days of submission. Any change in tax status of the **School** must be reported in writing to the **Sponsor** within ten (10) business days after notice to the **School** or the **School Governing Authority**, with a copy of any documentation and official/governmental notices or letters.

1.4 **Sponsor.** The **Sponsor** shall carry out the responsibilities established by law and provide monitoring, oversight and technical assistance to the Schools in accordance with R.C. 3314.03(D) by completing the following:

- (a) Monitor the **School's** compliance with the laws applicable to the **School** and with this Charter;
 - (i) Conduct site visits to the **School** as necessary, but at least twice annually while classes are in session with one visit during the first half of the school year and the other visit during the second half of the school year; and
- (b) Monitor and evaluate the academic performance and the organization of the **School** as delineated in the Performance Framework included as Attachment 6.4b, the state report cards issued for the **School** under R.C. 3302.03 and R.C. 3314.07 on at least an annual basis and provide the **School** and **School Governing Authority** with an annual report.
 - (i) Report on annual basis the results of the evaluation conducted under R.C. 3314.03(D)(2) to the department of education and to the parents of students enrolled in the community school; and
- (c) Provide reasonable technical assistance to the **School Governing Authority** in complying with this Charter and with applicable laws (provided, however, the **Sponsor** shall not be obligated to give legal advice to the **School Governing Authority** (*See 2.7 below*); and
- (d) Take steps to intervene in the **School's** operation to correct problems in the **School's** overall performance. If necessary, declare the **School Governing Authority** to be on probation pursuant to R.C. 3314.073. The **Sponsor** shall monitor the actions taken by the **School Governing Authority** to remedy the conditions that have warranted probationary status as specified by the **Sponsor**. The **Sponsor** may take over the operation of the **School**, if the material conditions are not remedied to the

reasonable satisfaction of the **Sponsor**. The **Sponsor** may also take steps to terminate the charter with the **School Governing Authority** or to suspend operation of the **School** if the **Sponsor** at any time finds that the **School Governing Authority** is no longer able or willing to remedy those material conditions to the reasonable satisfaction of the **Sponsor**.

- (e) Monitor and evaluate the **School's** fiscal performance and establish and/or require a plan of action to be undertaken if the **School** experiences financial difficulties before the end of the school year;
 - (i) Upon learning of financial difficulties, the **Sponsor** shall provide the **School Governing Authority** with a reasonable time frame to submit a plan of action; and
 - (ii) The **Sponsor** shall review and approve the plan within five (5) business days of receipt; and
- (f) Provide assurances in writing to the department of education not later than ten business days prior to the opening of the **School's** first year of operation or, if the **School** is not an internet- or computer-based community school and it changes the building from which it operates, the opening of the first year it operates from the new building, as required in R.C. Section 3314.19; and
- (g) Abiding by the requirements in its contract with the Ohio Department of Education; and
- (h) Other activities designed to specifically benefit the **School**.

ARTICLE II

School Governing Authority

- 2.1 **Governing Authority Members.** The **School Governing Authority** (its Board of Directors "Directors" or "Board") must contain at least five (5) Directors, who are not owners or employees, or relatives of owners or employees, of the **School** or any for-profit company that operates or manages the **School**. Further, **School Governing Authority** members shall be disinterested parties as defined by R.C. 102.03, 2921.42 and 2921.43. The Board shall provide the **Sponsor** with personal information not related to school business in order to enhance the Sponsor's ability to contact the Board, which personal information will not be attached to this Contract as it is not a public record. Current resumes, which shall include full name, home and/or work address, a valid telephone number and electronic mail address, for each **School Governing Authority** member will be provided to the **Sponsor** prior to the member being appointed to the **School Governing Authority**, but shall not be a part of this Contract. The **School Governing Authority** agrees to comply with the procedures by which the members of the **School Governing Authority** of the **School** will be selected in the future as set forth in its code of regulations. The **Sponsor** shall be notified of any changes in Directors in within five (5) business days of such change. **School Governing Authority** members

may be compensated per R.C. 3314.02(E)(5) in accordance with the Board's policy on compensation.

Each **School Governing Authority** member agrees to execute a conflict of interest statement on an annual basis and provide a copy to the Sponsor within ten (10) days of signing.

The **School Governing Authority** must meet at least six (6) times per year and must send notice of all regular meetings to the **Sponsor** at least three (3) business days prior to the meeting. If the **School Governing Authority** calls a special meeting, notice must be sent twenty-four (24) hours prior to the meeting. If the **School Governing Authority** calls an emergency meeting, notice must be sent immediately. The **School Governing Authority** must maintain a policy regarding how it will notify the public of all meetings. The **School Governing Authority** shall submit a meeting schedule to the **Sponsor** no later than July 1st of each school year. Any changes to the regular meetings schedule which affect all future meetings of the **School Governing Authority** shall be communicated within ten (10) business days of the change being approved. All names of **School Governing Authority** members shall be posted on the **School's** website and updated timely as necessary.

- 2.2 **Training of Governing Authority Members.** All new **School Governing Authority** members are required to attend Board training and shall begin the training within ninety (90) days of appointment and complete the training within six (6) months. Training for new members must be at least four (4) hours in length. Additionally, the training must be approved by the **Sponsor** prior to completion. Existing Board members are encouraged to participate in Board training on an annual basis to remain current regarding their responsibilities as a member of the **School Governing Authority**. The **Sponsor** reserves the right to require additional training of any **School Governing Authority** member(s) at the **Sponsor's** reasonable discretion.
- 2.3 **Criminal Background Checks of Governing Authority Members.** Under R.C. 3314.19(I), all School Governing Authority Members are required to obtain a criminal background check, including both a BCI and a FBI under the standards set out in RC. 3319.39, before serving on the Governing Authority. The **School** shall obtain the consent of each potential member of the Governing Authority to release that persons background checks to the **Sponsor** and to the **Governing Authority**. The BCI and FBI background checks must have been completed within one (1) year prior to the Governing Authority Member being appointed to the **School Governing Authority**. A copy of the BCI and FBI check will be submitted to the **Sponsor**. The **Sponsor** shall indicate preliminarily its approval of potential School Governing Authority member pursuant to the R.C. 3319.39 standards and communicate the approval to the **School Governing Authority**. The board has final approval of any new appointment to the Governing Authority.
- 2.4 **Material Adverse Effect.** The **School Governing Authority** shall deliver to the **Sponsor** promptly upon any director, trustee, officer, employee, management company employee or agent of the **School Governing Authority** obtaining knowledge of any event or circumstance that could reasonably be expected to have a material adverse effect on the operation, properties, assets, condition (financial or otherwise), prospects or reputation of the **School** including, but not limited to:

- (a) Any material breach of any covenant or agreement contained in this Charter, or
- (b) Any default notice given to the **School Governing Authority** or any other action taken with respect to a claimed default under any financing obtained by the **School Governing Authority**, or
- (c) The failure of the **School Governing Authority** to comply with the terms and conditions of any certificates, permits, licenses, governmental regulations, a report in reasonable detail of the nature and date, if applicable of such event or circumstance and the **School Governing Authorities'** intended actions with respect thereto; or
- (d) The institution of any action, suit, proceeding, governmental investigation or arbitration against or affecting the **School Governing Authority** or any property thereof (collectively, "Proceedings") not previously disclosed in writing by the **School Governing Authority**; or
- (e) Any material adverse development in any Proceedings to which the **School Governing Authority** is a party or the **School Governing Authority's** property is subject which may not be covered by insurance and the Treasurer's assessment of any financial impact to the school

Written notice of any of the above must be submitted to the **Sponsor** no later than ten (10) business days after receipt of notice provided to the **School Governing Authority**, a schedule of all Proceedings involving an alleged liability of or claims against or affecting the **School Governing Authority** or, if there has been no change since the last such report, a statement to that effect, shall timely be sent to the **Sponsor**. Other such information as may be reasonably requested by the **Sponsor** to enable the **Sponsor** and its counsel to evaluate any of such Proceedings shall be sent immediately upon request by the **Sponsor**.

2.5 **Sponsor Oversight.** The **School Governing Authority** and the **School's** administration covenant and agree to cooperate fully with the **Sponsor** in all activities as required by regulations of the Ohio Department of Education for oversight of the **School**. This includes, but is not limited to:

- (a) Compliance site visits as determined necessary by the **Sponsor**. The **School Governing Authority** or designee must maintain documentation of all verification of compliance.
- (b) Monthly reviews of financials. All financials, operating budgets, assets, liabilities, enrollment records or similar information must be submitted by the Fiscal Officer of the **School** to the **Sponsor** by email to financials@charterschoolspec.com no later than the 15th of every month for the previous months financial activity. The reports submitted may be in a format determined by the **School Governing Authority**, but must include:
 - (i) Cash Fund Report – a listing of all funds used showing the month's and year's activity and balances; and

- (ii) Revenue Summary – a listing of all revenue received for the month and for the year; and
- (iii) Statement of Net Position or Balance Sheet – statement showing assets, liabilities and net assets, in balance sheet form.
- (iv) Statement of Revenues, Expenses and Changes in Net Position or Income Statement – Statement showing monthly and year-to-date Revenue and Expenses comparative to corresponding budgeted amounts.
- (v) Check Register – a listing of all checks for the month; and
- (vi) Cash Reconciliation – a book to bank reconciliation of all cash accounts with copies of bank statements; and
- (vii) Aged Accounts Payable Detail – a listing of all outstanding accounts payable aged in 30 day increments; and
- (viii) Enrollment Records – in the form of monthly FTEs; and
- (viii) Copy of the monthly State Community School Statement of Settlement Report, and Detail Funding Report .

Fiscal Officers will be notified if a deadline is not met and/or if reports submitted do not contain all of the data required. Both the Fiscal Officer and **School Governing Authority** will be notified if the **Sponsor** or its designee does not receive the required data within seven (7) calendar days of the deadline. Additionally, failure to provide the **Sponsor** with the required data within fifteen (15) business days of the deadline may result in a Corrective Action Plan; and

- (c) Signature on this document shall be evidence of granting to the **Sponsor** to read-only access to EMIS, and hard copies of other reports such as testing, with personally identifiable student information redacted.
- (d) Other appropriate and reasonable requests for information from the **Sponsor**.
- (e) **Sponsor** representatives shall be included in executive sessions provided such session do not include disputes with or claims of or to the sponsor or matters subject to the attorney client privilege. When any **Sponsor** representative is included in an executive session, he/she will keep information discussed in executive session confidential.

- (f) The **School Governing Authority** shall have a post-audit conference unless waived by the Auditor of State’s office and the School. The **Sponsor** shall participate in the post-audit conference even if the **School Governing Authority** chooses not to participate.

- 2.6 **Technical Assistance and Training by Sponsor.** The **Sponsor** may provide technical assistance and training to the **School** and its staff at such times and to the extent that the **Sponsor** deems appropriate or as the current law requires. The **School, School employees** and **School Governing Authority** may be required to attend training and receive technical assistance at the direction of the **Sponsor**.
- 2.7 **Governing Authority Contracts.** If the **School Governing Authority** contracts with an attorney, accountant, or entity specializing in audits, the attorney, accountant, or entity shall be independent from the operator with which the School has contracted.
- 2.8 **Internal Financial Controls.** The **School Governing Authority** shall submit copies of all policies and procedures regarding internal financial controls, including the **School’s** credit card policy, adopted and include them as [Attachment 2.8](#) in this charter agreement.
- 2.9 **Public Records and Open Meetings Training.** The **School Governing Authority** members, the designated fiscal officer of the school, the chief administrative officer and other administrative employees of the school, and all persons contracted by the **School’s** operator for supervisory or administrative services shall complete training on an annual basis on the public records and open meetings laws.

ARTICLE III

Operations

- 3.1 **Student Transportation.** The **School Governing Authority** will work to assure that transportation of students is provided to the extent that such transportation is required by law and shall maintain a transportation plan in accordance with R.C. 3327.016 at all times. Under R.C. 3314.091 and 3327.02, the **School Governing Authority** must notify the local traditional public school district if the **School Governing Authority** will be accepting responsibility for student transportation. If the **School Governing Authority** has entered into an agreement with the local school district that designates the **School Governing Authority** as responsible for providing or arranging for the transportation of the district’s native students to and from the community school pursuant to R.C. 3314.091(A), the agreement shall be submitted to the **Sponsor** for approval. If the **School Governing Authority** assumes the responsibility for the transportation of the local district’s native students by notifying the local district pursuant to R.C. 3314.091(B)(2), then it shall notify the **Sponsor** of that decision and provide a transportation plan.

3.2 **Management by Third Parties.** Should the **School Governing Authority** enter into any contract for management or operation of the **School** or its curriculum or operations, or any portion thereof, such fully executed contract must be reviewed and negotiated by an attorney, independent of the **Sponsor** or the operator with which the **School** has contracted. The final contract shall be attached as [Attachment 3.2](#).

If the **School Governing Authority** desires to enter into a contract with an operator after execution of this Charter, change operators during the term of this Charter, or remove an operator and operate the **School** independently, the **School Governing Authority** shall submit information using the application provided by the **Sponsor**.

The **Sponsor** shall evaluate the proposed operator or independent operation and shall provide the **School Governing Authority** with a written response within ten (10) business days. The **Sponsor** shall approve the proposed operator or the **School's** independent operation, which approval shall not be unreasonably withheld, prior to execution of a contract with the proposed operator. If the proposed operator is approved, the **School Governing Authority** shall provide the **Sponsor** with the fully executed contract after its next scheduled Board meeting where in the new operator agreement is approved by the Board. This contract shall be incorporated as [Attachment 3.2](#).

If the management company provides services to the **School** in excess of twenty percent (20%) of the **School's** gross annual revenues, then the management company must provide a detailed accounting of the nature and costs of the services it provides to the **School**, acceptable to the Auditor of the State of Ohio. This information shall be included in the footnotes of the financial statements of the **School** and be subject to audit during the course of the regular financial audit of the community school.

If the management company or operator loans money to the **School** or **School Governing Authority**, all moneys loaned, including facilities loans or cash flow assistance, must be accounted for, documented, and bear interest at a fair market rate.

If the **School** permanently closes and ceases its operation as a community school, any property that was acquired by the operator or management company of the school in the manner prescribed in R.C. 3314.0210 shall be distributed in accordance with R.C. 3314.015(E) and R.C. 3314.074.

The **School Governing Authority** shall evaluate the performance of its management company based on the responsibilities of the management company in the management contract. This evaluation shall occur annually and a report of the evaluation shall be submitted to the **Sponsor** by **October 30th** of each year excluding the first year of operation.

3.3 **Non-Sectarian.** The **School** shall be nonsectarian in its programs, admission policies, employment practices, and all other operations, and will not be operated by a sectarian school or religious institution.

- 3.4 **Disposition of Assets.** To the extent permitted under Chapter 1702 of the Ohio Revised Code and the Internal Revenue Code with respect to a **School** which is a 501(c)(3) tax exempt organization, if the **School** permanently closes the **School and School Governing Authority** agree to distribute all assets in accordance with Section 3314.074 of the Ohio Revised Code. The **School** shall comply with the closing procedures as agreed to in [Attachment 3.4](#).
- 3.5 **Commencement of School Operations.** The **School** shall open for operation not later than September 30th of each school year, unless the mission of the **School** is solely to serve dropouts. In its initial year of operation, if the **School** fails to open by the thirtieth (30th) day of September, or within one (1) year after the adoption of the charter if the mission of the school is solely to serve dropouts pursuant to division (D) of section 3314.02 of the Revised Code, the charter shall be void.
- 3.6 **Safety Plan.** Under R.C. 3313.669, 3313.6610 and 5502.263, the **School Governing Authority or designee** shall submit to the appropriate required governmental or law enforcement agency, an electronic copy of its emergency management plan not less than once every three years, whenever a major modification to the building requires changes in the procedures outlined in the plan, and whenever information on the emergency contact information sheet changes.
- 3.7 **Racial and Ethnic Balance.** [Attachment 3.7](#) shall include the ways the **School** will achieve racial and ethnic balance reflective of the community it serves. Notwithstanding the admissions procedures of the **School**, in the event that the racial composition of the enrollment of the **School** is in violation of a federal desegregation order, the **School** shall take any and all corrective measures to comply with desegregation order. The **School Governing Authority** must assess the Racial and Ethnic Balance of the **School** each school year in order to make necessary adjustments to any marketing plans then used by the school in order to attempt to be reflective of either the community it serves or the local traditional public school district in which the **School** resides.
- 3.8 **Tuition.** Subject only to any applicable exception pursuant to R.C. 3314.26, tuition in any form shall not be charged for the enrollment of any student. Additionally, the **School Governing Authority** shall not require parents to volunteer in lieu of a tuition charge. Nothing in this section prevents reasonable activity or class fees as allowed by law, or the **School Governing Authority** engaging in voluntary fund-raising activities.
- 3.9 **Admissions Policy.** The admissions and enrollment procedures of the **School** are attached hereto as [Attachment 3.9](#). The **School** and/or **School Governing Authority** shall communicate any changes to the admissions and enrollment procedures within ten (10) business days after the change being approved. At a minimum, the admission procedures at all times must comply with R.C. 3314.06 and R.C. 3314.061 if applicable and must:

- (a) specify that the **School** will not discriminate in its admission of students to the **School** on the basis of race, religion, color, national origin, handicap, intellectual ability, athletic ability or measurement of achievement or aptitude;
- (b) be open to any individual entitled to attend school in the State of Ohio pursuant to section 3313.64 or section 3313.65 of the Ohio Revised Code, except that admission to the **School** may be limited to (i) students who have obtained a specific grade level or are within a specific age group, (ii) students that meet a definition of “at-risk,” as defined within this Charter, (iii) residents of a specific geographic area within the district, as defined in this Charter, (iv) separate groups of autistic students and nondisabled students under R.C. 3314.061 and as defined in this Charter, and/or (v) single-gender students of either sex.

If the number of applicants meeting admission criteria exceeds the capacity of the **School’s** programs, classes, grade levels or facilities, students shall be admitted by lot from all eligible applicants, except preference shall be given to students attending the **School** the previous year and may be given to eligible siblings of such students. In addition, if the **School** so wishes, preference may be given to students of full time staff of the **School** so long as such students comprise less than 5% of the total enrollment of the school. The lottery may be conducted by the **Sponsor**.

- (c) The **School Governing Authority** shall adopt a policy regarding the admission of students residing outside the district in which the **School** is located. That policy shall comply with the admissions procedures specified in sections 3314.06 and 3314.061 of the Revised Code and at the sole discretion of the authority, shall do one of the following:
 - (i) Prohibit the enrollment of students who reside outside the district in which the **School** is located; or
 - (ii) Permit the enrollment of students who reside in districts adjacent to the district in which the **School** is located; or
 - (iii) Permit the enrollment of students who reside in any other district in the state.
- (d) If the **School** serves kindergarten and first grade students, it may admit students early into kindergarten and first grade based on their local policy for early entrance. If it is the intent of the **School** to admit students who do not meet the statutory deadline for regular admission, the **School Governing Authority** must adopt its own local policy for early entrance.

3.9.1 The **School Governing Authority** agrees to provide notices to students, parents, employees and the general public indicating that all of the **School’s** educational programs are available to its students without regard to race, creed, color, national origin, sex and disability. Further, the **School** shall provide a non-discrimination notice in all newsletters, annual reports, admissions materials, handbooks, application forms and promotional materials other than radio advertisements.

- 3.9.2 The **School Governing Authority** agrees to provide a copy of the most recent Local Report Card to parents during the admissions process under R.C. 3313.6411(B).
- 3.10 **Attendance Policy.** The **School Governing Authority** must adopt an attendance policy that includes a procedure for automatically withdrawing a student from the **School** if the student, without a legitimate excuse, fails to participate in seventy-two (72) consecutive hours of the learning opportunities offered to the student. The **School** and **School Governing Authority** shall ensure all attendance and participation policies will be available for public inspection and comply with rule and law applicable to truancy and excessive absences. The **School's** attendance and participation records shall be made available to the Ohio Department of Education, auditor of state and the **Sponsor** to the extent permitted under and in accordance with the "Family Educational Rights and Privacy Act of 1974," 88 Stat. 571, 20 U.S.C. 1232g, as amended, and any regulations promulgated under that act, and R.C. 3319.321.
- 3.11 **Suspension and Expulsion Policies.** The **School Governing Authority** shall maintain a policy regarding suspension, expulsion, removal and permanent exclusion of a student that specifies among other things the types of misconduct for which a student may be suspended, expelled or removed and the due process related thereto. The **School's** practices pursuant to the policy shall comply with the requirements of sections 3313.66, 3313.661 and 3313.662 of the Ohio Revised Code. Those policies and practices shall not infringe upon the rights of handicapped students as provided by state and federal law and the **School** must also maintain a separate policy for the discipline of students receiving special education services. The **School** shall not suspend, expel or remove a student from the **School** under section 3313.66 of the Revised Code solely on the basis of the student's absences from **School** without a legitimate excuse.
- 3.12 **Students with Disabilities.** **School** will comply with all federal and state laws regarding the education of students with disabilities and be in a position to provide services upon admission and/or identification. The **School** shall provide legally required related services, or the **School Governing Authority** may contract for such related services. The **School Governing Authority's** plan to provide these services is included in [Attachment 3.12.](#)
- 3.13 **School Closure or Reconstruction.** The **School** agrees to remain open for students to attend until the end of the school year in which it is determined that the **School** must close. The programs provided to students in the final year of the **School** must continue without interruption or reduction unless program changes are approved in writing by the **Sponsor**. The **Sponsor** may operate the **School** in the event the **School Governing Authority** fails to continue until the end of the approved school year. Provided however, the **Sponsor** may suspend the operations or terminate the charter as otherwise indicated by law.
- 3.14 **Internet or Computer-Based Community Schools.** The **School Governing Authority** and **School**, if an internet or computer-based community school, shall comply with the

requirements in R.C. 3314.013 (Limits on start-up schools) and R.C. 3314.033 (Standards governing operation of internet – or computer – based community schools).

- 3.15 **Community School Bond.** No new **School** shall initiate operation after February 1, 2016, unless the **School Governing Authority** has posted a bond in the amount of fifty thousand dollars with the auditor of state. In lieu of the bond, the **School Governing Authority**, the **Sponsor** or the operator may deposit, with the auditor of state, cash in the amount of fifty thousand dollars as guarantee of payment under R.C. 3314.50. In lieu of a bond or a cash deposit, the **Sponsor** or the operator may provide a written guarantee of payment, which shall obligate the **Sponsor** or operator to pay the cost of audits of the **School** up to the amount of fifty thousand dollars. Any such written guarantee shall be binding upon any successor entity that enters into a contract to **Sponsor** or to operate the **School**, and any such entity, as a condition of its undertaking shall acknowledge and accept such obligation.
- 3.16 **Enrollment and Residency.** The **School Governing Authority** must adopt an Enrollment and Residency Policy in accordance with sections 3313.672, 3313.64, 3313.65, 3314.03 and 3314.11 of the Ohio Revised Code. The **School** shall annually submit to the Ohio Department of Education and auditor of state a report of each instance under which a student who is enrolled in the **School** resides in a children's residential center as defined under R.C. [5103.05](#).

ARTICLE IV

Compliance With Laws

- 4.1 **Compliance with State Laws.** The **School** shall comply with sections 9.90 (Purchase or procurement of insurance), 9.91 (Placement or purchase of tax-sheltered annuity for educational employees), 109.65 (Missing children clearinghouse – missing children fund), 121.22 (Public Meetings), 149.43 (Availability of public records for inspection and copying), 311.29 (Authority for the county sheriff to contract with a community school for police services), 2151.357, (Institution receiving children required to make report), 2151.421 (Reporting child abuse or neglect), 2313.19 (Employer may not penalize employee for being called to jury duty), 3301.07 (Requirement to report financial information to the State Board in the same manner as school districts), 3301.0710 (Ohio Graduation Tests), 3301.0711 (Administration and grading of tests), 3301.0712 (College and work ready assessments), 3301.0714 (Guidelines for statewide education management information system) (as stated in 3314.17), 3301.0715 (District board to administer diagnostic assessments – intervention services), 3301.723(C) (Data verification code for younger children receiving state services), 3301.0729 (Time Spent on Assessments), 3301.52 to 3301.59 (Preschool program standards and licensing), 3301.60 (Interstate Compact on Educational Opportunity for Military Children), 3301.947 (Privacy of data during testing), 3301.948 (Provision of data to multi-state consortium provided), 3302.037 (Notification of report card results to parents, board); 3302.13 (Reading achievement improvement plan requirements), 3309.013 (Exclusions from definition of employee under ORC section 3309.01), 3311.742 (Municipal school

district student advisory committees), 3313.131 (Member of governing authority of community school prohibited from membership on board of education), 3313.375 (Lease-purchase agreement for building or improvements to building), 3313.411 (Lease or sale of unused school facilities), 3313.472 (Policy on parental and foster caregiver involvement in schools), 3313.50 (Record of tests – statistical data – individual records), 3313.539 (Concussions and school athletics), 3313.608 (Third Grade Reading Guarantee), 3313.5310 (Information and training regarding sudden cardiac arrest); 3313.602 (Veteran’s Day Observance), 3313.605 (Community service education program), 3313.609 (Grade Promotion and Retention Policy) 3313.6012 (Policy governing conduct of academic prevention/intervention services), 3313.6013 (Dual enrollment program for college credit), 3313.6014 (Parental notification of core curriculum requirements), 3313.6015 (Resolution describing how district will address college and career readiness and financial literacy), 3313.6020 (Policy on Career Advising), 3313.6025 (Instruction on proper interactions with peace officers); 3313.6026 (FAFSA data sharing agreement); 3313.6111 (State seal of biliteracy), 3313.6411 (Providing report card to parent), 3313.643 (Eye protective devices), 3313.648 (Prohibiting incentives to enroll in district), 3313.66 (Suspension, expulsion or permanent exclusion- removal from curricular or extracurricular activities), 3313.661 (Policy regarding suspension, removal, expulsion and permanent exclusion), 3313.662 (Adjudication order permanently excluding pupil from public schools), 3313.666 (District policy prohibiting harassment required), 3313.667 (District bullying prevention initiatives), 3313.668 (Removal from school based on absences); 3313.669 and 3313.6610 (SAVE Students Act), 3313.67 (Immunization of pupils – immunization records – annual summary), 3313.671 (Proof of required immunizations – exceptions), 3313.672 (Presenting school records, custody order if applicable and certification of birth by new pupil), 3313.673 (Screening of beginning pupils for special learning needs), 3313.69 (Hearing and visual tests of school children – exemptions), 3313.71 (Examinations and diagnoses by school physician), 3313.7110 (Procurement of epinephrine autoinjectors for public schools), 3313.7112 (Requirements related to care of students with diabetes), 3313.7113 (Procurement of inhalers for board), 3313.716 (Possession and use metered dose inhaler or dry powder inhaler to alleviate asthmatic symptoms), 3313.718 (Possession and use of epinephrine auto-injector to treat anaphylaxis), 3313.719 (Food allergy protection policy), 3313.721 (Health care for students), 3313.80 (Display of national flag), 3313.814 (Standards governing types of food sold on school premises), 3313.816 (Sale of a la carte beverage items), 3313.817 (A la carte foods; determination of nutritional value; software), 3313.86 (Health and safety review), 3313.89 (Publication of information regarding online education and career planning tool), 3313.96 (Informational programs relative to missing children – fingerprinting program), 3317.161 (Approval of career-technical education programs), 3319.073 (In-service training in child abuse prevention programs), 3319.077 (Teacher professional development in dyslexia), 3319.078 (Multi-sensory structured literacy certification), 3319.22 through 3319.31 (Licensure/certification of employees), 3319.318 (Illegally assisting a sex offender in attaining school employment), 3319.321 (Confidentiality), 3319.39 (Criminal records check), 3319.391 (Applicants and new hires subject to criminal records check provisions), 3319.393 (Educator profile database consultation), 3319.41 (Corporal punishment policy), 3319.46 (Policy and rules regarding

positive behavior intervention supports and the use of physical restraint or seclusion), 3319.47 (Sexual harassment counseling), 3319.58 (Retesting teachers in low performance schools), 3320.01, 3320.02 and 3320.03 (Ohio Student Religious Liberties Act of 2019), 3321.041 (Excused absences for certain extracurricular activities), 3321.01 (Compulsory school age – requirements for admission to kindergarten or first grade – pupil personnel services committee), 3321.13 (Duties of teacher or superintendent upon withdrawal or habitual absence of child from school – forms), 3321.14 (Attendance officer – pupil-personnel workers), 3321.17 (Attendance officer and assistants – powers), 3321.18 (Enforcement proceedings), 3321.19 (Examination into cases of truancy – failure of parent, guardian or responsible person to cause child’s attendance at school), 3323.19 (Comprehensive eye examination), 3323.251 (Dyslexia screening), 3327.01, 3327.02 and 3327.09 (Student Transportation), 3327.10 (Qualifications of drivers), 3327.16 (Volunteer bus rider assistance program), 3333.31 (Rules for determining student residency), 3333.81 to 3333.88 (Requirements related to student participation in distance learning courses), 3365.032 (Notice of expulsion of student), 3737.73 (Fire, Tornado and Lockdown Drills), 4111.17 (Prohibiting discrimination in payment of wages), 4113.52 (Reporting violation of law by employer or fellow employee), 5502.262 (Safety Plans) and 5705.391 (Board of education spending plan), Chapters 117 (Auditor of State), 1347 (Personal Information Systems), 1702 (Non-Profit Corporation Law), 2744 (Political Subdivision Tort Liability), 3307 (State Teachers Retirement System), 3309 (Public School Employees Retirement System), 3314 (Community Schools), 3323 (Special Education), 3365 (Post-Secondary Enrollment Options Program), 3742 (Lead Abatement), 4112 (Civil Rights Commission), 4117 (Collective Bargaining Law), 4123 (Workers’ Compensation), 4141 (Unemployment Compensation), and 4167 (Public Employment Risk Reduction Program) of the Ohio Revised Code as if it were a school district. The **School** will comply with these sections and chapters of the Ohio Revised Code now in effect and as hereafter amended. Certain laws listed above which are not specified therein as mandatory, are permissive, unless otherwise specifically required under this Charter. Laws listed above which are mandatory, are also mandatory under this Charter.

The **School** shall comply with Chapter 102 (Public Officers – Ethics), section 2921.42 (Having an unlawful interest in a public contract) and section 2921.43 (Soliciting or accepting improper compensation) and 2921.44 (Dereliction of Duty) of the Ohio Revised Code. The **School Governing Authority** must maintain a general conflict of interest policy.

The **School** shall also comply with R.C. 3302.04 (Three year continuous improvement plan – intervention by department – site evaluations) and R.C. 3302.041 (Failure to make adequate progress – corrective actions), including division (E) of R.C. 3302.04 to the extent possible, except that any action required by a school district under R.C. 3302.04 shall be taken by the **Sponsor**. The **Sponsor**, however, shall not be required to take any action under R.C. 3302.04(F).

The **School** will comply with sections 3313.3021 and 3313.6023 of the Revised Code (Requirements to provide instruction in CPR and use of AED) as if it were a school

district unless it is either of the following: (i) An internet- or computer-based community school; (ii) A community school in which a majority of the enrolled students are children with disabilities as described in division (A)(4)(b) of section 3314.35 of the Revised Code.

The **School** will comply with section 3321.191 of the Revised Code (Adoption of policy regarding student absences; intervention strategies), unless it is an internet- or computer-based community school that is subject to section 3314.261 of the Revised Code.

The **School** shall comply with R.C. 3313.614 (Testing requirements for fulfilling curriculum requirement for diploma), and with R.C. 3313.61 (Diploma or honors diploma) and 3313.611 (Standards for awarding high school credit equivalent to credit for completion of high school academic and vocational education courses) except that for students who enter ninth grade for the first time before July 1, 2010, the requirement in R.C. 3313.61 and 3313.611 that a person must successfully complete the curriculum adopted by the governing authority of the community school rather than the curriculum specified in R.C. Title XXXIII or any rules of the state board of education. Beginning with students who enter the ninth grade for the first time on or after July 1, 2010, the curriculum of a high school prior to receiving a high school diploma shall be met by completing the Ohio core curriculum prescribed in R.C. 3313.603(C), unless the person qualifies under R.C. 3313.603(D) or (F). Each **School** shall comply with the plan for awarding high school credit based on demonstration of subject area competency, adopted by the State Board of Education under R.C. 3313.603(J).

The **School**, unless it is an internet- or computer-based community school, shall comply with 3313.801 (Display of national and Ohio Mottoes) as if it were a school district.

The **School** shall comply with Ohio Administrative Code Section 901:5-11-15 governing pesticide policies.

The **School** will comply with all provisions of Title IX.

- 4.2 **Compliance with Other Laws.** The **School** and the **School Governing Authority** may not carry out any act or ensure the performance of any function that is not in compliance with the United States Constitution, the Ohio Constitution, federal law, Ohio law and this Charter. The **School** and the **School Governing Authority** are not exempt from federal laws, rules and regulations, or other Ohio laws granting rights to parents.

ARTICLE V

Facilities

- 5.1 **Location of Facility.** The facility to be used for the **School** will be maintained at **92 North Union Street, Akron, Ohio 44304 and 280 Perkins, Akron, Ohio 44304.** If multiple facilities are used, the **School Governing Authority** shall comply with R.C. 3314.05. If the facility has been or will be leased, a copy of the fully executed lease and any lease renewals or amendments must be provided to the **Sponsor** within ten (10) business days of its execution and shall be incorporated into this charter as **Attachment 5.1(a).** If the facility has been or will be purchased by the **School Governing Authority**, a copy of the contract of sale and related documents must be provided to the **Sponsor** within ten (10) business days of execution, and after purchase, a copy of the recorded conveyance documents shall timely be provided to the **Sponsor**. Any lease, sub-lease or use of the facility by any party, including the management company, must be documented in writing.

The **School Governing Authority** shall provide the following information in **Attachment 5.1(b):**

- (a) a detailed description of each facility used for instructional purposes; and
- (b) the annual costs associated with leasing each facility that are paid by or on behalf of the school; and
- (c) the annual mortgage principal and interest payments that are paid by the school; and
- (d) the name of the lender or landlord, identified as such, and the lender's or landlord's relationship to the operator, if any.

The facility will not be changed and the number of square feet used will not be reduced without prior notification to the **Sponsor**. Any lease, mortgage payments, or capital improvement costs must be consistent with the latest budget given to and approved by the **Board**. In any change of facility, the **Sponsor**, at its sole discretion, but without obligation to do so, may request maps, plans and/or revised budgets showing adequate service of the debt and reserves for maintenance or repairs, and/or attorney, accountant or financial consultant assurances or opinions regarding structure, financing or otherwise. If the **School** changes locations, adds a satellite location or annex, the **Sponsor** shall conduct an opening assurances visit at the new location and submit assurances to the Ohio Department of Education at least ten (10) business days prior to the **School** using the new facility. The **Sponsor** shall not be liable for the debts, obligations or business of the **School** or the **School Governing Authority**, but may request any information the **Sponsor** deems necessary to assess adequate planning for facilities.

- 5.2 **Compliance with Health and Safety Standards.** Any facility used by the **School Governing Authority** for or by the **School** shall meet all health and safety standards established by law for community school buildings. The **School** shall not begin operations either at start up or after any structural change requiring permits until which time the **Sponsor** has viewed all health and safety permits and if in order, provided the

School an Assurances Document as specified by the State Board of Education. Facilities will be maintained in a clean, healthy manner as indicated by proper authorities. Copies of all current permits, inspections and/or certificates must be filed with the **Sponsor**. The **School** must keep all permits, inspections and/or certifications current and compliant.

- 5.3 **Closure of School.** If the **School** should close for any reason, the **School Governing Authority** is solely responsible for the sale, lease or other distribution of the facility. The **School Governing Authority** agrees to maintain the facility until such time as the facility is sold or leased to another entity.

ARTICLE VI

Educational Program

- 6.1 **Number of Students.** The **School** will provide learning opportunities to the minimum number of students as required by R.C. 3314.03(A)(11)(a); and as applicable, for a minimum of nine hundred twenty (920) hours per school year or in accordance with any applicable changes of law. **The School is authorized to serve grades K-5 and ages 5-12.** The **School** shall provide an education plan as detailed in [Attachment 6.3](#) for all grades it is authorized to serve. The education plan shall include the characteristics and ages of the students to be served, including grade configuration and enrollment projections for the next five (5) years. If the **School Governing Authority** desires to add additional grades to the **School**, it shall submit a resolution requesting a charter modification to add grades and modify the education plan. Unless already authorized to serve additional grades, the **Sponsor** shall evaluate the request for added grades and shall evaluate any modifications and respond accordingly and **Sponsor's** approval shall be timely (within ten (10) business days) and not unreasonably withheld. The number of students attending the **School** at any one time shall not exceed the number allowed by the occupancy permit (including staff).
- 6.1.1 Not including any period in which the Governor has declared a state of emergency, if the **School** is a traditional K-12 education institution and does not have at least one-hundred (100) students enrolled thirty (30) days prior to the first day of school or if the **School** is a drop-out recovery and prevention school and does not have at least seventy-five (75) students enrolled thirty (30) days prior to the first day of school, the **Sponsor** shall review the number of students enrolled, the financial and organizational position of the **School** and all other opening assurances requirements as prescribed by the Ohio Department of Education. If the **Sponsor** determines that the number of students enrolled and the financial position of the **School** are not sufficient for the **School** to remain open for the entire school year, the **Sponsor** will require a guarantee of funding from the management company or other sources to keep the **School** in operation for the entire school year. The **School** will provide the guarantee and all necessary financial data relative to the funding sources for approval prior to the due date for

opening assurances documents to be submitted to the Ohio Department of Education.

6.1.2 If the **School** is a traditional K-12 education school and does not maintain at least one-hundred (100) students during the school year or if the **School** is a drop-out recovery and prevention school and does not maintain seventy-five (75) students during the school year, the **Sponsor** may place the **School Governing Authority** on a Corrective Action Plan, Probation or Suspend the **School's** operations.

6.2 **Continuing Operation.** The **School** agrees to continue operation by teaching the minimum number of students permitted by law or this Charter, whichever is greater. Time is of the essence in continuing operation. Failure to continue operation without customary interruption is grounds for termination of this Charter.

6.3 **Curriculum.** For purposes of this Charter, in [Attachment 6.3](#), the vision, mission, philosophy, goals, focus of the curriculum and objectives shall be separated from the methods used to achieve those goals. The **School Governing Authority** shall provide a clear mission statement which shall be incorporated into [Attachment 6.3](#). Any change in vision, mission, philosophy, goals, focus of the curriculum and objectives methods would constitute a material change in the Charter and must be requested through a charter modification process. Any Charter modification must be submitted to the **Sponsor** in writing for approval. Upon approval by the **Sponsor**, the **School Governing Authority** shall pass a resolution outlining in detail the changes made. The **School's** curriculum must be aligned to the Ohio's Learning Standards including English, Language Arts and Mathematics, Science and Social Studies content standards and any additional content areas for which standards have been established and/or revised per R.C. 3301.079. The **School** must demonstrate at any given time, and to the **Sponsor's** satisfaction, the implementation of the aligned curriculum as stated in this section. [Attachment 6.3](#) encompasses a description of the learning opportunities that will be offered to students including both class-room based and non-classroom-based learning opportunities that is in compliance with criteria for student participation established by the department under R.C. 3314.08(H)(2). [Attachment 6.3](#) shall also include an explanation of how the educational program will be implemented within the **School's** facility.

6.3.1 The **School Governing Authority** shall provide the **Sponsor** with a school calendar that includes testing/assessment dates [state, diagnostics, nationally normed and local] and professional development days and bell schedule that includes collaborative teacher planning time each year for approval by a date prescribed by the Ohio Department of Education. The **School Governing Authority** shall consult with each local traditional school district that transports students to the **School** before changing the calendar or bell schedule which would change transportation drop off, pick-up or days and times needing transportation. Any changes made without this communication may result in a corrective action plan.

6.3.2 The **School** shall develop a prevention/intervention plan (not related to the special education non-discriminatory evaluation process) for all students not found

proficient on the Ohio system of assessments and/or the current tests being required by the Ohio Department of Education. Each year, the **School** shall update the plan and develop additional plans relative to individual student performance.

- 6.4 **Accountability Standards.** The **School's** academic and non-academic goals shall be reflected in the **School's** School Improvement Plan approved by the **School Governing Authority**. During the first year a **School** enters into sponsorship with St. Aloysius, the **School** shall establish two academic and one non-academic goal that will impact grade card performance and align to grade card components by October 15th. Each year, the **School** will be assessed on its performance on these goals and applicable local report card measures per the performance framework in [Attachment 6.4](#). If the **School** does not meet the goals established in [Attachment 6.4](#) it will be placed in intervention status. The **School Governing Authority** and **Sponsor** acknowledge that some performance measures may not be available for a given school, a particular contract year, or instances when state testing or report cards are not available. In the absence of data from state testing or report cards, the **School** will be evaluated, to the extent possible, on available indicators from the performance framework, and the **Sponsor** may consider qualitative data from other methods of data collection.
- 6.5 **Assessments and Performance Standards.** The performance standards (requirements) and assessments shall include the Ohio system of assessments according to R.C. 3301.0710 and R.C. 3301.0712, college and work ready assessments, ACT/SAT WorkKeys, industry credentialing examinations, OELPA, Kindergarten Readiness Assessment (KRA), nationally normed standardized assessments recognized by the Ohio Department of Education as a student growth measure and any other standards and/or assessments required by law or recommended by the **Sponsor**. All assessments must be timely and properly administered. The nationally normed standardized assessment approved by the Ohio Department of Education as a student growth measure chosen by the **School** must be administered at a minimum of twice annually to all grade levels, excluding Kindergarten, with the vendor generated reports for measures of academic progress and analysis in reading and math being provided to the **Sponsor** upon request and no later than June 30th of each school year. The **School** must assess and keep benchmarks related to interim progress if required by the Ohio Department of Education. The **School** must report the benchmarks required by ODE to the **Sponsor**. All assessments required by the **Sponsor** are identified in [Attachment 6.5](#). Testing shall not exceed the limits established by law, unless by resolution of the **School Governing Authority**. The **School** and **School Governing Authority** shall also comply with all applicable provisions of ESSA.
- 6.6 **High School Diplomas and Graduation.** If the **School** is a high school awarding a diploma, the **School** shall comply with sections 3313.603, 3313.6013, 3313.61, 3313.611, 3313.6110, 3313.6114, 3313.614, 3313.615, 3313.617, 3313.618, 3301.0710, 3301.0711, 3301.0712, 3301.0714, 3314.03, 3326.11 and 3328.34 of the Ohio Revised Code as applicable. At least thirty (30) days before any graduation, the **School** shall make available upon request a list of graduates and proof of meeting all Ohio Department of

Education graduation requirements and any other School Governing Authority requirements to the **Sponsor**. Within ten (10) business days of any graduation, the **School** shall provide electronically to the **Sponsor** a list of all graduates and copies of each graduate's diploma and transcripts.

ARTICLE VII

Reporting

- 7.1 **Annual Report.** The **School Governing Authority** shall submit not later than October 31st (or any subsequent statutorily prescribed date) of each year to the **Sponsor** and to the parents of all students enrolled in the **School**, or any other statutorily required parties, its financial status, and the annual report of its activities and progress in meeting the goals and standards of this Charter, local report card rating, adequate yearly progress rating, value added rating and school improvement status of the most current school year as issued by ODE and statement from the **Sponsor**, as well as its activities and standards. The **School** shall also provide a copy of the **Sponsor's** annual report to parents each year prior to November 30.
- 7.2 **Reports to Sponsor.** The **School Governing Authority** shall timely comply with all reasonable requests for information from the **Sponsor**, including the **School** financial reports required in section 2.5 of this Charter.
- 7.3 **Site Visits.** The **Sponsor** shall be allowed to observe the **School** in operation at site visits at the **Sponsor's** request and shall be allowed access for such site visits or other impromptu visits as the **Sponsor** deems advisable or necessary, provided the **Sponsor** does not disturb the educational process or testing.

ARTICLE VIII

Employees

- 8.1 **Employment of Teachers.** At least one (1) full-time classroom teacher or two (2) part-time classroom teachers each working more than twelve (12) hours per week must be employed by the **School**. The full-time classroom teachers and part-time classroom teachers teaching more than twelve (12) hours per week shall be certified or licensed in accordance with Ohio Revised Code Sections 3302.01, 3302.03, 3311.78, 3311.79, 3314.03, 3317.141, 3319.22 to 3319.31, and 3326.13 or other applicable sections of the Ohio Revised Code. Upon request, the **School** shall forward teacher qualifications, including but not limited to, the grade level and content area being taught and the teacher's licensure or certification granted by the Ohio Department of Education, to the **Sponsor**. The **School** may employ non-licensed persons to teach up to twelve (12) hours or forty (40) hours per week pursuant to R.C. 3319.301, to the extent permitted by ESSA or any subsequent legislation. There shall be no more than twenty-nine (29) students per classroom on a schoolwide average. If the **School** uses federal funds for the purpose of class size reduction by using Title 1 or Title II-A funds, the school wide students to full-

time equivalent classroom teacher ratio shall be no more than 1 to 25. The **School** may also employ necessary non-teaching employees. Prior to opening day, the **School** will provide the **Sponsor** with proof of Ohio licensure/certification for a sufficient number of teachers to support the stated teacher/student ratio, as well as the credentials and background checks for all staff of the **School**. The **School Governing Authority** shall provide an organizational chart and a list of roles and responsibilities of all **School** staff as shown on [Attachment 8.1](#).

8.1.1 Each person employed by the **School** as a nurse, teacher, counselor, school psychologist or administrator shall complete at least four (4) hours of in-service training in the prevention of child abuse, violence and substance abuse and the promotion of positive youth development within two (2) years of commencing employment with the **School**, and every five (5) years thereafter.

8.2 **Staff Evaluation.** Except for years in which state law exempts school districts the requirement of completing evaluations set forth in R.C. 3319.111 and/or 3319.02, each **School** must use the OTES and OPES process, or similar valid model, for evaluating teachers and principals/superintendents that includes goal setting based on the Ohio Standards for the Teacher Profession or the Ohio Principal Standards or the Ohio Superintendent Standards, student performance measures (as defined by the Ohio Department of Education), and an annual review that includes not less than two (2) formal observations and written evaluation reports. Any person conducting reviews must be credentialed by the Ohio Department of Education, hold a current credential at the time of the evaluations, and follow rubrics aligned to the OTES and OPES models. A **School Governing Authority** member or designee and/or regional manager of the management company shall undergo appropriate training/credentialing by the Ohio Department of Education and be responsible for evaluating the principal/superintendent.

8.3 **Dismissal of Employees.** Subject to 11.2 below, the **School Governing Authority** may employ administrators, teachers and non-teaching employees necessary to carry out its mission and fulfill this Charter, so long as no contract of employment extends beyond the term of this Charter. The requirements and procedures regarding the disposition of employees of the **School** in the event this Charter is terminated or not renewed under R.C. 3314.07 are set out in [Attachment 8.3](#).

8.4 **Employee Benefits.** The **School** must provide to all full-time employees' health and other benefits as set out in [Attachment 8.4](#). In the event certain employees have bargained collectively pursuant to Chapter 4117 of the Ohio Revised Code, the collective bargaining agreement supersedes [Attachment 8.4](#) to the extent that the collective bargaining agreement provides for health and other benefits. The collective bargaining agreement shall not, under any circumstances, be a part of this Charter. The **School** shall establish and/or update an employee handbook prior to the first day of school each year.

8.5 **Criminal Background Check.** The **School Governing Authority** must request that the superintendent of the Bureau of Criminal Identification & Investigation conduct a criminal background records check for any applicant who has applied to the **School** for

employment, in any position. The **School Governing Authority** hereby appoints the **Sponsor** as a representative pursuant to R.C. 3319.39(D) for purposes of receiving and reviewing copies of the results of the criminal records checks performed under R.C. 3319.39(A)(1) for employees working at the **School** and authorizes its agent(s) (including educational management organizations) to communicate this information directly to the **Sponsor**. The **Sponsor** agrees that it is responsible for any and all reasonable costs or damages that result from the **Sponsor's** failure to comply with other state and federal laws regarding the privacy of the results of criminal records checks. The Board or its chief administrator shall receive all originals and the Board or the operator (if it employs the employees) shall make all final decisions as to hiring. An applicant may be employed conditionally for up to sixty (60) days until the criminal records check is completed and the results of the criminal records check are received. If the results of the criminal records check indicate that the applicant does not qualify for employment the applicant shall be released from employment.

As required by 3314.41, and as applicable, vendors and contractors of any kind shall show proof, which may be provided through their employer, that they have been the subject of a criminal records check in accordance with R.C. 3319.392(D).

All employees, staff, volunteers, vendors or contractors undergoing a criminal background check must sign consent to release the results to the **Sponsor**.

The **School** must comply with the teacher misconduct reporting laws and updated background check requirements found in R.C. 3319.31, 3319.313, 3319.314, 3319.314 and OAC 3301-20.

ARTICLE IX

Finance

- 9.1 **Financial Records.** The **School's** financial records will be maintained in the same manner as are financial records of school districts, pursuant to rules of the Auditor of the State, R.C. 3314.042 and R.C. 3301.07, and audits shall be conducted in accordance with section 117.10 of the Ohio Revised Code. The **Sponsor** shall receive a copy of the draft audit and shall be notified, by the Auditor of State, any independent contracted auditor or the **School Governing Authority**, of all post audit conferences in order to review the school's annual audit prior to the document being finalized and released.
- 9.2 **Fiscal Officer.** The **School Governing Authority** shall maintain a designated fiscal officer. Unless an appropriate and timely resolution has been passed by the **School Governing Authority** under R.C. 3314.011(D)(1), the fiscal officer shall be employed or engaged under a contract directly with the **School Governing Authority**. This resolution must be passed by the **School Governing Authority** each and every year. The **School Governing Authority** must submit the resolution to the **Sponsor** for approval within seven (7) business days after approval. Under 3314.011, prior to assuming the duties of

fiscal officer, agent and/or fiscal servicer of the **School**, the fiscal officer, agent or service provider shall be licensed as provided for in Ohio Revised Code 3301.074.

- 9.2.1 R.C. 9.24 prohibits any state agency or political subdivision from awarding a contract for goods, services, or construction to any person against whom a finding for recovery has been issued by the Auditor of State, if that finding is unresolved. Before entering into a public contract described above, the **School Governing Authority** is required to verify that the person does not appear in this database.
- 9.2.2 The **School Governing Authority** must maintain funds equal to three (3) months of treasurer fees in the event the **School** closes.
- 9.3 **Fiscal Bond.** The fiscal agent, officer and/or service provider shall execute a bond in an amount and with surety to be approved by the **School Governing Authority**, payable to the State of Ohio, conditioned for the faithful performance of all of the official duties required of the **School** fiscal agent, officer or service provider. The bond shall be in an amount of not less than twenty-five thousand dollars (\$25,000). The bond shall be deposited with the **School Governing Authority**, and a copy thereof, certified by the **School Governing Authority**, shall be filed with the county auditor and the **Sponsor**.
- 9.4 **Budget.** A financial plan detailing an estimated school budget for the first year of the period of this Charter and specifying the total estimated per pupil expenditure amount for each such year and at least five (5) fiscal years thereafter is attached as [Attachment 9.4](#). Each year, the **School Governing Authority**, with the assistance of the **School's** designated fiscal officer, shall adopt an annual budget by the thirty-first day of October using the format and following the guidelines prescribed by the Ohio Department of Education. The **Sponsor** shall assess the yearly budget to ensure the **School Governing Authority** maintains financial viability. Should the **Sponsor** reasonably request further breakdown of revenue or expenses, or line items for expenses or revenue not projected, the **School** agrees to comply with such requests. Should the **School** be managed by a third-party operator, the **School Governing Authority** must procure from such operator, sufficient data, at the **Sponsor's** reasonable discretion, to allow the **Sponsor** to review revenue and expenses as required and/or permitted by law.
- 9.5 **Borrowing Money.** The **School Governing Authority** may borrow money to pay necessary and actual expenses of the **School** in anticipation of receipt of any portion of the payments to be received by the **School**. The **School Governing Authority** may issue notes to evidence such a borrowing. A copy of all notes must be provided to the **Sponsor** within ten (10) business days of signing. The proceeds from the notes shall be used only for the purpose for which the anticipated receipts may be lawfully expended by the **School**. The **School** may borrow money for a term not to exceed fifteen (15) years for the purpose of acquiring facilities.
- 9.6 **Payment to Sponsor for Oversight.** For and in consideration of Three percent (3%) of all funds received by the **School** from the State of Ohio, the **Sponsor** shall provide the monitoring, oversight and technical assistance as required by law. Payments to the **Sponsor** may be made by monthly ACH debit from the **School's** checking account, and the **School Governing Authority** agrees to sign a Recurring ACH Payment

Authorization form. Automatic ACH debits for sponsorship fees will be initiated five (5) business days after the state foundation payments are received by the **School**, allowing treasurers time to review and/or dispute the amount to be debited. If the **School** should close, payments to the **Sponsor** shall be made in full after all retirement funds of school employees and salary obligations have been fulfilled to **School** employees. If the **School Governing Authority** is required to repay funds received by the **School** from the State of Ohio due to an FTE adjustment or other obligation, then the **Sponsor** shall repay the **School Governing Authority** the three percent (3%) fee it received with respect to such funds upon mutual agreement of the parties within an agreed upon timeframe or such time as may be required by the Ohio Department of Education or the Auditor of State.

9.7 **Fiscal Year**. The fiscal year for the **School** shall be July 1 to June 30.

ARTICLE X

Insurance/Indemnification

10.1 **Liability Insurance**. Commercial general liability insurance at all times will be maintained by the **School Governing Authority** in amounts not less than one million dollars (\$1,000,000) per occurrence and two million dollars (\$2,000,000) in the aggregate, plus an excess or umbrella policy extending coverage as broad as primary commercial general liability coverage in an amount no less than five million dollars (\$5,000,000). The **School Governing Authority** shall also maintain comprehensive general liability, including directors' and officers' liability (D&O) and errors and omissions insurance (E&O) coverage in the amount of one million dollars (\$1,000,000) per occurrence and one million dollars (\$1,000,000) aggregate. The insurance coverage shall be not only for the **School** and the **School Governing Authority**, its Directors, officers and its employees but also provide additional insured status for the **Sponsor, its Board, Executive Director, employees, and Charter School Specialists as additional insureds, not just certificate holders**. The **School Governing Authority** must obtain policies that notify the **Sponsor** in writing at least thirty (30) days in advance of any material adverse change to, or cancellation of, such coverage. All insurers shall be licensed by the State of Ohio and have an AM Best rating of A or better.

10.2 **Indemnification**. The **School Governing Authority** and **School** shall defend, indemnify, save and hold harmless the **Sponsor** and its Board, Superintendent, officers, employees and agents, including Charter School Specialists from any and all claims, debts, actions, causes of actions, proceedings, judgments, mitigation costs, fees, liabilities, obligations, damages, losses, costs or expenses (including, without limitation, attorneys', expert, accounting, auditors or other professionals' fees and court costs) of whatever kind or nature in law, equity or otherwise (collectively "Liabilities") arising from any of the following so long as not the fault of the indemnified parties:

- (a) A failure of the **School Governing Authority** and/or **School** or any of its officers, directors, employees, agents or contractors to perform any duty, responsibility or obligation imposed by law or this Charter;

- (b) An official action or omission by the **School Governing Authority** and/or **School** or any of its officers, directors, employees or contractors that results in injury, death or loss to person or property, breach of contract or violation of statutory law or common law (state and federal), or Liabilities;
- (c) Any sum that the **Sponsor** may pay or become obligated to pay on account of: (1) any inaccuracy or breach of any representation under this Charter; (2) any breach or any failure of the **School Governing Authority** to duly perform, comply with, or observe any term, provision, covenant, agreement, obligation or condition under this Charter or under the law, and all agreements delivered in any way connected herewith, on the part of the **School Governing Authority**, to be performed, complied with, or observed; or (3) Liabilities to lenders, vendors, the State of Ohio, receivers, parents, students, the **School Governing Authority** or to third parties in any way related to the **School** and/or **School Governing Authority**; and
- (d) Any Liabilities incurred by the **Sponsor** or any of its officers, directors, employees, agents or contractors as a result of an action or legal proceeding at law or equity brought against the **Sponsor** by a third party based on operations of the School, unless the **third party** obtains a final judgment or order on the merits against the **Sponsor**, and the right to appeal such judgment or order has been exhausted or has expired.

10.3 **Indemnification if Employee Leave of Absence.** If the **Sponsor** provides a leave of absence to a person who is thereafter employed by the **School**, the **School Governing Authority** and the **School** shall indemnify and hold harmless the **Sponsor** and its board members, Superintendent, employees and agents from liability arising out of any action or omission of that person while that person is on such leave and employed by the **School Governing Authority**.

ARTICLE XI

General Provisions

11.1 **Charter Authorization.** Before executing this Charter, the **School Governing Authority** shall employ an attorney, who shall be independent from the **Sponsor** or operator, to review and negotiate the agreement per R.C. 3314.036. The **School Governing Authority** must pass a resolution in a properly noticed and held public meeting, authorizing execution of this Charter and authorizing one or more individuals to execute this Charter for and on behalf of the party, with full authority to bind the party. For all new schools, this resolution must be passed by March 15th of the year in which the **School** intends to open. For renewal schools, this resolution must be passed by June 1st of the year in which the charter ends.

11.2 **Termination and Cancellation of Contracts.** Except as otherwise permitted by this Charter, or by the **Sponsor**, contracts entered into by the **School Governing Authority** with third parties shall provide for a right to cancel, terminate or non-renew effective each June 30th, or upon termination of this Charter.

11.3 **General Acknowledgements.** The **School Governing Authority** specifically recognizes and acknowledges the following:

- (a) The authority of public health and safety officials to inspect and order **School** facilities closed if not in compliance with health and safety laws and regulations in accordance with R.C. 3314.03(A)(22)(a).
- (b) The authority of the Ohio Department of Education to suspend the operations of the **School** under R.C. 3314.072 due to the circumstances enumerated therein.
- (c) The **Sponsor** is not liable for the acts or omissions, or the debts of the **School** and/or **School Governing Authority** pursuant to R.C. 3314.07(D) and 3314.08(J) (2), and any other applicable law limiting the liability of the **Sponsor**.
- (d) The **Sponsor** may take steps to intervene in, correct, declare probationary status of, suspend, terminate or non-renew the status of the **School** as an Ohio Community School, and correct problems in the **School's** performance.
- (e) The Ohio Department of Education may take over sponsorship of the **School** in accordance with R.C. 3314.015(C).
- (f) The authority of the Auditor of State to cause legal action against or the cessation of payments to the **School** pursuant to Section 269.60.60 of the uncodified law under H.B. 119 of the 127th General Assembly for the period of that law's duration.
- (g) The mandate of permanent closure under R.C. 3314.35 under the circumstances enumerated therein.
- (h) Consistent with the Sponsor's responsibilities, the **Sponsor** has a legitimate educational interest in the educational records of the **School** consistent with any use in the **School's** interest, and the **School** grants to the **Sponsor** and the **Sponsor's designee** access to educational records with personally identifiable information redacted unless absolutely necessary for Sponsor to see, under 20 U.S.C. § 1232g, the Family Rights and Privacy Act ("FERPA"). The **Sponsor** shall indemnify the **School** for any costs or damages associated with the **Sponsor's** breach of this provision.

- (i) If the **School** closes, the chief administrative officer shall collect and assemble in an orderly manner the educational records of each student who is or has been enrolled in the **School** and transmit these records to each student's district of residence within seven (7) business days of the **School** closing pursuant to R.C. 3314.44 (Collection and transmittal of school records after closing; Compliance; Penalty).

11.4 **Dispute Resolution.** The **Sponsor** and **School Governing Authority** agree to informal mediation of any dispute not otherwise governed by mandatory administrative procedures pursuant to this Charter or the law. Such mediation shall be non-binding and the parties, if failing to agree on one mediator, shall obtain a list of three (3) mediators from the Columbus Bar Association or the Ohio Bar Association and each eliminate one, using the one (1) mediator left after eliminations. All mediation will take place in Franklin County and all costs of the mediator shall be split equally between the parties.

11.5 **Term.** This Charter shall be for a term of four (4) years commencing on July 1, 2020 and ending on June 30, 2024. During the **2023-2024** school year, the **School Governing Authority** shall undergo the high stakes review conducted by the **Sponsor**. The high stakes review shall include a review of the data included in the performance framework of **Attachment 6.4**.

11.6 **Contract Performance Measures.** Each new school will be given an initial term of six (6) years to provide the opportunity for review of a full five (5) years of data. If St. Aloysius is not permitted under its agreement with ODE to grant an initial six (6) year term to any new school, this school's term shall be automatically renewed to fulfill an initial six (6) year term to provide the opportunity for review of a full five (5) years of data. Even though schools may be granted safe harbor from closure under R.C. 3314.35, this does not preclude the **Sponsor** from evaluating and closing the **School** for non-performance under these measures.

- (a) Within the term of this charter, the **School** may be permanently closed if the Ohio Department of Education determine that the condition(s) outlined in ORC 3314.35 have been met;

- (b) If the **School** receives a rating of at least 2 Stars [Meets] or higher in at least one (1) applicable grade card component for the most recent school year or its overall report card score as calculated on the local report card is greater than three (3) of the five (5) comparison schools listed below, the **School** shall be eligible to be considered for renewal. If an overall report card score is not available, the schools will be compared using the index value as calculated for the progress component on the local report card or equivalent measure. After the **School** is eligible for renewal, a high stakes review will be conducted based on the performance framework comprised in Attachment 6.4 and the renewal application.

- (i) If the **School** is renewed and it received a grade of at least 2 Stars [Meets] in only (1) applicable grade card component for the most recent school year, the **Sponsor** may offer a new charter agreement up to three (3) years.
 - (ii) If the **School** receives at least 2 Stars [Meets] in multiple LRC graded components and outperforms at least three (3) of its five (5) comparison schools, it is eligible for a contract term between three (3) and five (5) years.
 - (iii) If the **School** received a grade of at least 3 Stars [Meets] in multiple LRC graded components for the most recent school year, the **Sponsor** may offer a new charter agreement between five (5) years and seven (7) years.
 - (iv) If the **School** receives at least 4 Stars in multiple LRC graded components, it is eligible for a contract term between seven (7) to ten (10) years.
- (c) The comparison schools for the **School** are as listed below:
- i) **Akron Preparatory School**
 - ii) **Case Preparatory Academy**
 - iii) **Leggett Elementary School**
 - iv) **Eagle Academy**
 - v) **Middlebury Academy**

11.7 **Non-renewal of this Charter.**

- (a) Consistent with the standards in 11.6 above, the **Sponsor** may choose not to renew this Charter at its Expiration Date for any of the following reasons:
 - (i) Failure to meet student performance requirements stated in this Charter;
 - (ii) Failure to meet generally accepted standards fiscal management;
 - (iii) Violation of any provision of this Charter or applicable state or federal law;
 - (iv) Other good cause.

By January 15th of the termination year of this Charter, the **Sponsor** shall notify the **School Governing Authority** of the proposed action in writing. The notice shall include the reasons for the proposed action in detail, the effective date of the non-renewal, and a statement that the **School Governing Authority** may, within fourteen (14) days of receiving the notice, request in writing, an informal hearing before the

Sponsor. The informal hearing shall be held within fourteen (14) days of the receipt of a request for the hearing. Within fourteen (14) days following the informal hearing, the **Sponsor** shall issue a written decision either affirming or rescinding the decision to not renew this Charter.

- (b) If the **School Governing Authority** does not intend to renew this Charter with the **Sponsor**, the **School Governing Authority** shall notify the **Sponsor** in writing of that fact at least one hundred eighty (180) days prior to the expiration of this Charter. In such a case, the **School Governing Authority** may enter into a Charter with a new **Sponsor** in accordance with R.C. 3314.03, upon the expiration of this Charter or at the sole discretion of the **Sponsor**, by an assignment of this Charter before its expiration date.

11.8 **Probation.** The **Sponsor** may, in lieu of suspension or termination, declare in writing that the **School Governing Authority** is in a probationary status, after consulting with the **School Governing Authority** or authorized parties thereof, and specifying the conditions that warrant probation and after receiving the **School Governing Authority's** written assurances (satisfactory to **Sponsor**) of the actions and time frames necessary to remedy those conditions. Such probationary status shall not extend beyond the current school year. The **Sponsor** may proceed to suspension, termination or take-over of operations if the **Sponsor** finds at any time, that the **School Governing Authority** is no longer able or willing to remedy the conditions to the satisfaction of **Sponsor**. For purposes of this Charter, the **Sponsor** agrees to attempt to declare probationary status with the **Governing Board**, before proceeding to suspension, except in extraordinary circumstances such as those involving the health and safety of students, or waste or illegal use of state or federal funds.

11.9 **Intent to Suspend/Suspension.** The **Sponsor** may suspend operations of the **School** for (1) failure to meet student performance requirements stated in this Charter, or (2) failure to meet generally accepted standards of fiscal management, or (3) violation of any provision of this Charter or applicable state or federal law, (4) other good cause or if funding to the School Governing Authority should cease under R.C. 263.420, if the **Sponsor** sends a written notice of intent to suspend explaining the reasons and provides the **School Governing Authority** with five (5) business days to submit a remedy, and promptly reviews and disapproves the proposed remedy, or if the **School Governing Authority** fails to submit a remedy or fails to implement the remedy. Intent to suspend will be in accordance with the standards adopted by the Sponsor as to suspension and termination existing at the inception of this contract.

Once the **School Governing Authority** is suspended it must cease operations on the next business day, immediately send notice to all **School** employees and parents stating that the **School** is suspended and the reasons therefore, and the **School** again has an opportunity to submit a proposed remedy within five (5) business days. At all times

during suspension, the **School Governing Authority** remains subject to non-renewal or termination proceedings in accordance with the law.

Under R.C. 3314.03, if the **School Governing Authority** fails to remedy the conditions cited by the **Sponsor** as reasons for the suspension by the thirtieth (30th) day of September of the school year immediately following the school year in which the operation of the **School** was suspended, this Charter shall become void.

- 11.10 **Termination of the Charter.** The **Sponsor** may choose to terminate this Charter for any of the following reasons: (1) failure to meet student performance requirements stated in section 11.6 title Contract Performance Measures of this Charter, (2) failure to meet generally accepted standards fiscal management, (3) violation of any provision of this Charter or applicable state or federal law, or (4) other good cause. Termination will be in accordance with the standards adopted by the **Sponsor** as to suspension and termination existing at the inception of this contract.

Additionally, if the **Sponsor** has suspended the operation of this Charter under R.C. 3314.072, the **Sponsor** may choose to terminate this Charter prior to its expiration.

By January 15th of the termination year of this Charter, the **Sponsor** shall notify the **School Governing Authority** of the proposed action in writing. The notice shall include the reasons for the proposed action in detail, the effective date of the termination, and a statement that the **School Governing Authority** may, within fourteen (14) days of receiving the notice, request, in writing, an informal hearing before the **Sponsor**. The informal hearing shall be held within fourteen (14) days of the receipt of a request for the hearing. Within fourteen (14) days following the informal hearing, the **Sponsor** shall issue a written decision either affirming or rescinding the decision to terminate this Charter.

The termination of this Charter shall be effective upon the occurrence of the later of the following events:

- (a) the date the **Sponsor** notifies the **School Governing Authority** of its decision to terminate this Charter as provided for above; or
- (b) if an informal hearing is requested and as a result of that hearing the **Sponsor** affirms its decision to terminate this Charter, the effective date of the termination specified in the notice,

If this Charter is terminated for failure to meet student performance or for failure to meet generally accepted standards of fiscal management pursuant to this provision, then the **School Governing Authority** shall not enter into a charter with any other **Sponsor**.

- 11.11 **Access to Records.** The **School** and **Sponsor** agree and state that pursuant to 20 U.S.C. Section 1232g, the Family Rights and Privacy Act (“FERPA”) and 34 *CFR* Part 99 the **Sponsor** is an authorized representative of a state educational authority and that the

School is permitted to disclose to **Sponsor** personally identifiable information from an education record of a student without parental consent (or student consent where applicable) and that the **Sponsor** is authorized by Federal, State, and local law to conduct audit, evaluation, compliance, and enforcement activities of Federal and State supported education programs. Accordingly, the **School** agrees to grant to **Sponsor's** employees Full and Complete Access as defined hereinafter to "education records" as defined by FERPA and all documents, records, reports, databases, and other information made available to or maintained by the **School** or its agent(s) (including educational management companies) that is reportable to the Ohio Department of Education or to the Ohio Auditor of State. Such information shall include, but is not limited to, the School Options Enrollment System, and the Education Management Information System. "Full and Complete Access" shall include the ability to inspect and copy paper and electronic documents at the **School** and the **School** or its agent(s) including (education management companies) shall provide usernames and passwords where applicable to enable the **Sponsor** to have remote self-service access in read-only format.

The **Sponsor** agrees to comply with FERPA and the regulations promulgated thereunder and warrants that it uses reasonable methods to limit Sponsor employee(s) access to only those records in which they have legitimate educational interests and that as required by law the **Sponsor** will destroy the educational records when no longer needed for the purposes outlined in this Contract, or otherwise needed under state or federal law or any applicable Court Order.

The **Sponsor** agrees that it is responsible for any and all reasonable costs or damages that result from the **Sponsor's** failure to comply with FERPA, or the **Sponsor's** failure to comply with other state and federal laws regarding the privacy of education records and the results of criminal records checks. Sponsor shall also be responsible for any liability or adverse consequence(s) resulting from an accidental or other deletion, release, or alteration of information or data systems of the School or Ohio Department of Education as a result of such access.

- 11.12 **Compliance with Requests of Sponsor.** The **School Governing Authority** and the **School** shall timely comply with all reasonable requests of the **Sponsor** and allow the **Sponsor** to monitor the **School** operations. Failure to do so is grounds for suspension and termination or non-renewal of this Charter. Timeliness is defined as an answer in writing within ten (10) business days (unless a shorter time is otherwise required pursuant to this Charter) and adequate assurances of cure or actual cure within a period of time acceptable to the **Sponsor**.
- 11.13 **Headings.** Headings are for the convenience of the parties only. Headings have no substantive meaning.
- 11.14 **Assignments.** This Charter and its terms shall not be assigned or delegated without the express written approval of the other party.

11.15 **Notice.** Any notice to one party by the other shall be in writing and effective upon receipt and may be satisfied by personal delivery or by any other means by which receipt can be documented, to; in the case of the **Sponsor** or **Sponsor’s Designee**, the President; or, in the case of the **School Governing Authority**, the President, and to the attorney for the **School Governing Authority**, at the last known business address of the **Sponsor**, and the last known business or home address of the **School** and/or its administrator or any board member.

Should the **School** be abandoned by or not have in place, an administrator or an authorized Director of the Board, the **Sponsor** may give notice to the Ohio Department of Education.

11.16 **Severability.** Should any term, clause or provision of this charter be deemed invalid or unenforceable by a court of competent jurisdiction, all remaining terms, clauses or provisions shall remain valid and enforceable and in full force and effect, and the invalid or unenforceable provision shall be stricken or replaced with a provision as near as possible to the original intent.

11.17 **Changes or Modifications.** This Charter constitutes the entire agreement among the parties and any changes or modifications of this Charter shall be made and agreed to in writing, authorized and executed by both parties. Notifications required by this Charter shall not be considered changes or modifications of this Charter. Mutually agreed-to changes that are not mid-contract term changes shall be based on a goal to improve the academic, financial and operational performance of the **School** in a commitment to mutual growth and progress. The **School Governing Authority** acknowledges that the **Sponsor** is expected to update this Contract mid-term annually to account for changes in law or duly adopted rule, or changes in the Ohio Accountability System. Therefore, the **School** agrees that a mid-contract term modification may be necessary annually.

11.18 **Changes in Rule or Law.** The School, Sponsor and School Governing Authority shall not carry out any act or perform any function that is not in compliance with current Ohio Community School Law located in Ohio Revised Code Chapter 3314 or other applicable laws in the Ohio Revised Code, the United States Constitution, the Ohio Constitution, or Federal law (including but not limited to ESSA or successor legislation and IDEA), and that they are each individually subject to all applicable changes in rule and/or law regardless of whether or not this Charter is modified to specifically reflect those changes.

11.19 **Attachments.** All **Attachments (1.3-9.4)** to this Charter are attached hereto and incorporated by reference into the Charter.

[Signatures on following page]

Executed this 9 day of June, 2022 in Akron, Ohio.

St. Aloysius

**School Governing Authority of
The Edge Academy**

By: DocuSigned by:
John Bandy
D068D4AADCA443B
(Name)
President and CEO
Its: _____
(Title)

By: Staci Yereb
(Name)
Its: Board President
(Title)

with full authority to execute this Charter for and on behalf of the **Sponsor** and with full authority to bind the **Sponsor**.

with full authority to execute this Charter for and on behalf of the **School Governing Authority** and with full authority to bind the **School Governing Authority**.

ARTICLES OF INCORPORATION
OF THE EDGE ACADEMY
A NON-PROFIT CORPORATION

The undersigned, citizens of the United States, desiring to form a non-profit corporation under Chapter 1702 of the Ohio Revised Code for the purpose of the establishment of one or more Community Schools to be known as The Edge Academies within the State, do hereby certify:

ARTICLE I
NAME

- 1.1 The name of the Corporation is The Edge Academy

ARTICLE II
PRINCIPAL OFFICE

- 2.1 The State and County of the Corporation's principal office is the State of Ohio and County of Summit. The address of the Corporation's principal office is 3865 Deer Run Parkway, Richfield, Ohio 44286.

ARTICLE III
PURPOSE

- 3.1 The principle purpose for which the Corporation is formed and organized is to provide for the creation, operation, administration, and financial support for Community Schools to be known as the Edge Academies.

To accomplish the purpose as set forth above, the Corporation may engage in such activities, as the Trustees of the Corporation deem necessary and advisable to:

- (a) Solicit contributions from the community including sponsorship of fundraising activities for the purpose of supplies, equipment and technical expertise which is necessary for and to be used in conjunction with the operation and administration of the Edge Academies; and,

- (b) Obtain any grants, as may be available for the purpose which is to provide funds for the operation and administration of the Edge Academies including the purchase of supplies and equipment; and,
- (c) To encourage community awareness, participation and support of the operation and administration of the Edge Academies; and,
- (d) To do everything necessary, proper, advisable, or convenient for the accomplishment of the purposes or the attainment of any of the objectives or the furtherance of any of the powers set forth in these Articles of Incorporation, incidental to or pertaining to, the operation and administration of the Edge Academies, and at all times to comply with the provisions of the Ohio Revised code, Sections 1702.01 et. Seq., as presently enacted and as may be amended or suspended by any other statute in the future.

**ARTICLE IV
TRUSTEES**

4.1

- (a) Initial Trustees- the initial Trustees of the Corporation shall be three (3) in number and shall serve until such time as their successors are appointed pursuant to the provisions of these Articles or a Code of Regulations as may be adopted.

<u>NAME</u>	<u>ADDRESS</u>
David Dudas	3865 Deer Run Parkway Richfield, Ohio 44286
Susan Dudas	3865 Deer Run Parkway Richfield, Ohio 44286
Betty J. Godard	2837 N. Revere Rd. Akron, Ohio 44333

- (b) Permanent Trustees – David Dudas, Susan Dudas, and Betty J. Godard shall be permanent Trustees so long as those persons are willing and able to serve in such capacity, and except for discharge for cause, shall not be subject to involuntary removal, nor shall they be subject to election, as their term shall extend so long as they desire to serve.

- (c) **Other Trustees – Any person may serve as a Trustee. The term of service shall be for two (2) years unless: (1) such person be appointed to fill a vacancy in which case the term shall be for the remainder of the term of the person so replaced; (2) such person is appointed as a Trustee for a lesser term by the resolution of the Board of Trustees; or, (3) such person’s term is terminated for any reason including resignation, death, and inability to serve as Trustee.**

A Trustee may resign at any time by giving written notice to the Corporation at least fifteen (15) days prior to such resignation.

A Trustee may be discharged with or without cause at any time without notice by a majority of the Trustees.

If any person is unwilling or unable to serve as a Trustee then such person may appoint another person to serve in their place. Such appointment shall be subject to the approval of the then existing Trustees who are entitled to vote. If any person, being unwilling or unable to serve does not consent to an appointment of an individual; then a majority of the then Trustees by their affirmative vote may elect a person to serve in place of the Trustee, however, such person shall replace, but in any case not more than two (2) years without again being subject to re-election.

**ARTICLE V
SHARE STRUCTURE**

Number and Type

- 5.1 The corporation shall not have and is not authorized to have outstanding any shares of Capital Stock.**

**ARTICLE VI
STATED CAPITAL**

- 6.1 The amount of capital with which the Corporation shall begin business is Five Hundred Dollars (\$500.00)**

**ARTICLE VII
AMENDMENT TO ARTICLES**

- 7.1** The Corporation by a majority vote of the Trustees eligible to vote reserves the right at any time, and from time to time, to amend these Articles of Incorporation in the manner now or in the future permitted by statute. Any change authorized by the Trustees having a majority of the voting power of the Corporation (or a greater number as may then be required by statute) shall be binding and conclusive on every Trustee of the Corporation as fully as if each Trustee had voted for the change.

**ARTICLE VIII
INTERESTED TRUSTEES AND OFFICERS**

- 8.1** A Trustee or Officer of the Corporation shall not be disqualified by office from dealing or contracting with the Corporation as a vendor, purchaser, employee, agent or otherwise. No act of the corporation shall be void or voidable or in any way affected by reason of the fact that any Trustee or Officer of the Corporation is also a member of a firm, an officer, a director, a shareholder, or a Trustee or beneficiary of a trust, or otherwise connected with any other enterprise, in any way interested in the act. No Trustee or Officer shall be accountable or responsible to the Corporation for or in respect to any act of the Corporation or for any gains or profits directly or indirectly realized by reason of the fact that the Trustee or Officer or any firm of which he or she is a member, or any corporation of which he or she is an officer, shareholder, director, or trustee, or any trust of which he or she is connected, is interested in the act. The fact that the Trustee or Officer, or that the firm, corporation, trust or other entity is interested shall be disclosed or shall have been known to the Board of Trustees or the members of the Board present at any meeting of the Board of Trustees at which action on the transaction is taken. Any interested Trustee may be counted in determining the existence of a quorum at any meeting of the Board of Trustees that authorized or take actions in respect to any transaction; any interested Trustee may vote to authorize, ratify, or approve the transaction. Any officer of the Corporation may take any action within the scope of his or her authority, respecting any act, with like force and effect as if he or she, or any other entity with which he or she is connected, were not interested in the act. Without limiting or qualifying the foregoing, if any judicial or other inquiry, suit, cause, or proceeding, the question of whether a Trustee or Officer of the Corporation has acted in good faith is material, and notwithstanding any statute or rule of law or of equity to the contrary (if there are any) his or her good faith by presumed in the absence of clear and convincing evidence and proof to the contrary.

**ARTICLE IX
INDEMNIFICATION**

Right to Indemnification

9.1 The Corporation shall indemnify each of its Officers, Trustee, and employees, whether or not then in office, and his or her heirs and legal representatives, against all expenses, judgments, decrees, fines, penalties, or other amounts paid in satisfaction, in settlement or, or in connection with the proceeding, civil or criminal, to which he or she is or may be made a party by reason of having been a Trustee, Officer or employee of the Corporation. Without limitation, the term "expenses" shall include all counsel fees, expert witness fees, court costs, and any other costs of a similar nature. The Corporation shall net, however, indemnify any Officer, Trustee or employee until a majority of the Board of Trustees has determined by a majority vote at a meeting, or by a written instrument signed by a majority of all the Trustees, that the Office Trustee or employee:

(a) Was not grossly negligent in his or her duty to the Corporation of guilty of intentional misconduct in the performance of duties to the Corporation;

(b) Acted in good faith in what he or she reasonably believed to be in the best interests of the Corporation; and,

(c) In any matter subject to criminal action, suit or proceeding, had no reasonable cause to believe that the conduct was unlawful.

In making this determination, all of the Trustees, including any Trustee who is party to or threatened with the action, suit or proceeding shall be entitled to vote at meeting or sign the written instrument and by those means be counted for all purposes in determining a majority of the Board of Trustees.

9.2 Any Officer, Trustee, or employee who is entitled to indemnification from the Corporation may make a written demand on the Board of Trustees by serving the written demand on the president or the Secretary, (unless the President and the Secretary are both making the demand, in which case service may be made on any other Officer of the Corporation).

If the Board of Trustees does not, within fifteen (15) days after service of the written demand, determine that the Officer, Trustee or employee is entitled to indemnification, the Officer, Trustee, or employee may, within sixty (60) days following the date of service of the demand, apply to a court of general jurisdiction in the county where the Corporation maintains its principal office, to consider the matters referred to in Subparagraphs (a), (b), and (c) of Paragraph 9.1. If the court determines that the conduct of the Officer, Trustee or employee was such as to meet the requirements in subparagraphs, the court shall order the corporation to indemnify the Officer, Trustee or employee to the same extent as if the Board of Trustees had originally made the determination.

**ARTICLE X
MEMBERSHIP**

10.01 The Corporation shall not have Members but the Trustees shall serve as Members...

**ARTICLE XI
OFFICERS**

11.01 The Trustees of the Corporation shall elect persons to serve in the capacity of President, Vice President, Secretary and Treasurer. The duties of officers shall be set forth in the By-Laws of the Corporation. The officers shall serve at the pleasure of the Board of Trustees for terms not to exceed one (1) year.

**ARTICLE XII
FISCAL YEAR**

12.01 The Corporation's Fiscal Year shall commence on July 1 and end on June 30, except for the first fiscal year which year shall commence as of the date of the incorporation and end on May 31, 1999.

**ARTICLE XIII
DISSOLUTION OF THE CORPORATION**

13.01

(a) The dissolution of the Corporation shall require a two-thirds (2/3) vote of the then serving Trustees of the Corporation.

(b) In the event that the Corporation is dissolved, all of the Corporation's assets shall be marshaled and shall be contributed to an organization which is tax-exempt and has as its principal purpose, the creation and organization of community schools within the Akron area and if no such organization exists, then to an organization whose principal purpose is education of children grades K-6.

ARTICLE XIV

LIMITATION ON USE OF CORPORATE ASSETS

14.01 No person, Trustee, Officer, employee or member shall use any asset of the Corporation for their personal use and no person, Trustee, Officer, employee or Member shall be entitled to any moneys or properties as a result of their membership or position in the corporation. Notwithstanding the foregoing sentence and subject to the limitations of Article VIII, persons who are Members, Officers, or Trustees of the Corporation may conduct business with the Corporation if such business is in the best interest of the Corporation and in furtherance of the Corporation's principal purpose.

**ARTICLE XV
COMPENSATION OF OFFICERS AND TRUSTEES**

15.01 No person serving as an Officer or Trustee shall be entitled to any compensation therefore, provided however, the reasonable and necessary expenditures of any person in furtherance of the business of the Corporation may be reimbursable by the Corporation upon the approval of the President and the Treasurer.

IN WITNESS WHEREOF, the undersigned Incorporators have signed these Articles of Incorporation this ____ th day of _____, 1998.

David Dudas

Susan Dudas

Betty J. Godard

ORIGINAL APPOINTMENT OF AGENT

FOR

THE EDGE ACADEMY

A NON-PROFIT CORPORATION OF THE STATE OF OHIO

The undersigned, being the Incorporators of the above—named Corporation, hereby appoint Dave Dudas, to be Statutory Agent, upon whom any process, notice or demand required or permitted by statute to be served upon this Corporation may be served.

The full address of the Agent is 3865 Deer Run Parkway, Richfield, Ohio 44286, County of Summit.

THE EDGE ACADEMY

David Dudas

Susan Dudas

Betty J. Godard

County of Summit, Ohio _____, 1998

The undersigned hereby accepts the foregoing appointment as Agent of the Corporation upon who process, tax notices or demand may be served.

David Dudas, Statutory Agent

Return To:
GEORGE L. HOFF
528 STRATFORD AVE
AKRON, OH 44303-0800

cut along the dotted line



The State of Ohio
❖ *Certificate* ❖

Secretary of State - Bob Taft

1040045

It is hereby certified that the Secretary of State of Ohio has custody of the business records for EDGE LEARNING, INC. and that said business records show the filing and recording of:

Documental
DOMESTIC ARTICLES/NON-PROFIT

Document No(s):
188830001553

United States of America
State of Ohio
Office of the Secretary of State

Witness my hand and the seal of the Secretary
of State at Columbus, Ohio, This 30th day of
July, A.D. 1998



Bob Taft

Bob Taft
Secretary of State

Received by:

Name _____
Telephone () _____
Function _____
Date / / _____

Power of Attorney (Please type or print.)

1 Taxpayer Information (Taxpayer(s) must sign and date this form on page 2, line 2.)

Taxpayer name(s) and address Edge Learning, Inc. 3365 Deer Run Oval Richfield, Ohio 44286	Social security number(s)	Employer identification number
	Daytime telephone number (330) 376-4963	Plan number (if applicable)

hereby appoint(s) the following representative(s) as attorney(s)-in-fact:

2 Representative(s) (Representative(s) must sign and date this form on page 2, Part II.)

Name and address George L. Hoff, Attny. 529 Stratford Avenue Akron, Ohio 44303	CAF No. 3205-20209R Telephone No. (330) 376-4963 Fax No. (330) 376-4963 Check if new: Address <input type="checkbox"/> Telephone No. <input type="checkbox"/>
Name and address	CAF No. _____ Telephone No. () _____ Fax No. () _____ Check if new: Address <input type="checkbox"/> Telephone No. <input type="checkbox"/>
Name and address	CAF No. _____ Telephone No. () _____ Fax No. () _____ Check if new: Address <input type="checkbox"/> Telephone No. <input type="checkbox"/>

to represent the taxpayer(s) before the Internal Revenue Service for the following tax matters:

3 Tax Matters

Type of Tax (Income, Employment, Excise, etc.)	Tax Form Number (1040, 941, 720, etc.)	Year(s) or Period(s)
Application for Exemption	1023	1998

4 Specific Use Not Recorded on Centralized Authorization File (CAF).—If the power of attorney is for a specific use not recorded on CAF, check this box. (See Line 4—Specific uses not recorded on CAF on page 3.)

5 Acts Authorized.—The representatives are authorized to receive and inspect confidential tax information and to perform any and all acts that I (we) can perform with respect to the tax matters described on line 3, for example, the authority to sign any agreements, consents, or other documents. The authority does not include the power to receive refund checks (see line 6 below), the power to substitute another representative unless specifically added below, or the power to sign certain returns (see Line 6—Acts authorized on page 4).

List any specific additions or deletions to the acts otherwise authorized in this power of attorney: _____

Note: In general, an unenrolled preparer of tax returns cannot sign any document for a taxpayer. See Revenue Procedure 81-38, printed as Pub. 470, for more information.

Note: The tax matters partner/person of a partnership or S corporation is not permitted to authorize representatives to perform certain acts. See the Instructions for more information.

6 Receipt of Refund Checks.—If you want to authorize a representative named on line 2 to receive, BUT NOT TO ENDORSE OR CASH, refund checks, initial here _____ and list the name of that representative below.

Name of representative to receive refund check(s): _____

31-1624476



STATE OF OHIO
DEPARTMENT OF TAXATION
SALES AND USE TAX
BLANKET EXEMPTION CERTIFICATE

The purchaser hereby claims exception or exemption on all purchases of tangible personal property and selected services made under this certificate from:

X _____
(vendor's name)

and certifies that the claim is based upon the purchaser's proposed use of the items or services, the activity of the purchaser, or both, as shown hereon:

Purchaser, namely Edge Learning, Inc. is a tax exempt organization
under Section 501(c)(3) of the Internal Revenue Code of 1986 and is
exempt from Sales Tax under Section 5739.02(B)(12) of the Ohio Revised Code.

PURCHASER MUST STATE A VALID REASON FOR CLAIMING EXCEPTION OR EXEMPTION.

The Edge Academy
Purchaser's Name

92 N. Union St.
Street Address

Akron, OH 44304
City State Zip

[Signature] PRES.
Signature and Title

JULY 25, 2005
Date Signed

N/A
Vendor's License Number, if any

Vendors of motor vehicles, titled watercraft and titled outboard motors may use this certificate to purchase these items under the "resale" exception. Otherwise, purchasers must comply with rule 5703-9-10 of the Administrative Code.

This certificate cannot be used by construction contractors to purchase material for incorporation into real property under an exempt construction contract. Construction contractors must comply with rule 5703-9-14 of the Administrative Code.

INTERNAL REVENUE SERVICE
DISTRICT DIRECTOR
P. O. BOX 2508
CINCINNATI, OH 45201

DEPARTMENT OF THE TREASURY

Date: **APR 21 1999**

EDGE LEARNING INC
3865 DEER RUN OVAL
RICHFIELD, OH 44286

Employer Identification Number:
31-1624476
DIN:
17053327051038
Contact Person:
GARY MOTHERT ID# 31518
Contact Telephone Number:
(877) 829-5500
Accounting Period Ending:
June 30
Form 990 Required:
Yes
Addendum Applies:
Yes

Dear Applicant:

Based on information supplied, and assuming your operations will be as stated in your application for recognition of exemption, we have determined you are exempt from federal income tax under section 501(a) of the Internal Revenue Code as an organization described in section 501(c)(3).

We have further determined that you are not a private foundation within the meaning of section 509(a) of the Code, because you are an organization described in sections 509(a)(1) and 170(b)(1)(A)(ii).

If your sources of support, or your purposes, character, or method of operation change, please let us know so we can consider the effect of the change on your exempt status and foundation status. In the case of an amendment to your organizational document or bylaws, please send us a copy of the amended document or bylaws. Also, you should inform us of all changes in your name or address.

As of January 1, 1984, you are liable for taxes under the Federal Insurance Contributions Act (social security taxes) on remuneration of \$100 or more you pay to each of your employees during a calendar year. You are not liable for the tax imposed under the Federal Unemployment Tax Act (FUTA).

Since you are not a private foundation, you are not subject to the excise taxes under Chapter 42 of the Code. However, if you are involved in an excess benefit transaction, that transaction might be subject to the excise taxes of section 4958. Additionally, you are not automatically exempt from other federal excise taxes. If you have any questions about excise, employment, or other federal taxes, please contact your key district office.

Grantors and contributors may rely on this determination unless the Internal Revenue Service publishes notice to the contrary. However, if you lose your section 509(a)(1) status, a grantor or contributor may not rely on this determination if he or she was in part responsible for, or was aware of, the act or failure to act, or the substantial or material change on the part of the organization that resulted in your loss of such status, or if he or she acquired knowledge that the Internal Revenue Service had given notice that you would no longer be classified as a section 509(a)(1) organization.

Letter 947. (DO/CG)



JON HUSTED
OHIO SECRETARY OF STATE

180 East Broad Street, Suite 103 (ground floor) • Columbus, Ohio 43215
Toll Free: (877) SOS-FILE (767-3453) Central Ohio: (614) 466-3910
www.OhioSecretaryofState.gov • busserv@OhioSecretaryofState.gov

Please return the approval certificate to:

Name:

Edge Learning Inc.
(Individual or Business Name)

To the attention of:

Chris Perin
(if necessary)

Address:

92 N. Union St

City:

Acron

State:

Ohio ZIP Code: 44304

Phone Number:

330-535-4571

E-mail Address:

cperin@edge4kids.org

- Check here if you would like to receive important notices via e-mail from the Ohio Secretary of State's office regarding Business Services.
- Check here if you would like to be signed up for our Filing Notification System for the business entity being created or updated by filing this form. This is a free service provided to notify you via e-mail when any document is filed on your business record.

Type of Service Being Requested: (PLEASE CHECK ONE BOX BELOW)

- Regular Service:** Only the filing fee listed on page one of the form is required and the filing will be processed in approximately 3-7 business days. The processing time may vary based on the volume of filings received by our office.
- Expedite Service 1:** By including an Expedite fee of \$100.00, in addition to the regular filing fee on page one of the form, the filing will be processed within 2 business days after it is received by our office.
- Expedite Service 2:** By including an Expedite fee of \$200.00, in addition to the regular filing fee on page one of the form, the filing will be processed within 1 business day after it is received by our office. This service is only available to walk-in customers who hand deliver the document to the Client Service Center.
- Expedite Service 3:** By including an Expedite fee of \$300.00, in addition to the regular filing fee on page one of the form, the filing will be processed within 4 hours after it is received by our office, if received by 1:00 p.m. This service is only available to walk-in customers who hand deliver the document to the Client Service Center.
- Preclearance Filing:** A filing form, to be submitted at a later date for processing, may be submitted to be examined for the purpose of advising as to the acceptability of the proposed filing for a fee of \$50.00. The Preclearance will be complete within 1-2 business days.



Form 534A Prescribed by:
JON HUSTED
Ohio Secretary of State
Central Ohio: (614) 466-3910
Toll Free: (877) SOS-FILE (767-3453)
www.OhioSecretaryofState.gov
Busserv@OhioSecretaryofState.gov

Mail this form to one of the following:

Regular Filing (non expedite)
P.O. Box 670
Columbus, OH 43216

Expedite Filing (Two-business day processing
time requires an additional \$100.00).
P.O. Box 1390
Columbus, OH 43216

Name Registration

Filing Fee: \$50

CHECK ONLY ONE (1) Box

Trade Name
(167-RNO)

Date of first use:

MM/DD/YYYY

Fictitious Name
(169-NFO)

Name being Registered or Reported

Name of the Registrant

Note: If the registrant is a partnership, please provide the name of the partnership. Individual partner names are not permitted but are required on page 2 of the form.

The Registrant is a(n): (Check only one (1) box)

<input type="checkbox"/> Individual	<input type="checkbox"/> Ohio Corporation Charter # <input type="text"/>
<input type="checkbox"/> General Partnership Registration #, if any <input type="text"/>	<input type="checkbox"/> Foreign Corporation Ohio license # <input type="text"/>
<input type="checkbox"/> Limited Partnership Registration # <input type="text"/> If Foreign, Jurisdiction of Formation <input type="text"/>	Jurisdiction of Formation <input type="text"/>
<input type="checkbox"/> Limited Liability Partnership Registration # <input type="text"/> If Foreign, Jurisdiction of Formation <input type="text"/>	<input type="checkbox"/> Unincorporated Association
<input type="checkbox"/> Limited Liability Company Registration # <input type="text"/> If Foreign, Jurisdiction of Formation <input type="text"/>	<input type="checkbox"/> Professional Association Charter # <input type="text"/>
	<input type="checkbox"/> Sole Proprietor
	<input checked="" type="checkbox"/> Other NOT FOR PROFIT PUBLIC CHARTER SCHOOL

AMENDED AND RESTATED CODE OF REGULATIONS
OF THE
EDGE LEARNING, INC.

ARTICLE I
PURPOSE

Section 1. Purpose. Edge Learning, Inc. (the "Corporation") is organized exclusively for charitable and educational purposes within the meaning of Section 501(c)(3) of the Internal Revenue Code of 1986, as amended, or the corresponding provision of any future United States Internal Revenue law to operate as a community school in the State of Ohio.

ARTICLE II
MEMBERSHIP

Section 1. Membership. The Corporation shall not have Members. The Directors of the Corporation, in conformance with the procedures established for the Board of Directors and to the extent required by law, shall have the authority that is granted to, and carry out the duties that are imposed upon, the Members of a nonprofit corporation under Ohio law.

ARTICLE III
DIRECTORS

Section 1. Number. The number of Directors of the Corporation shall be at least three (3) and no more than twelve (12) or such greater number as may be subsequently determined by the Directors; provided however, in no case shall the number of Directors be less than five (5) once the Corporation has entered into a community school contract with a sponsor, unless Ohio law is amended to allow the governing authority of an Ohio community school to be composed of less than five (5) Directors.

Section 2. Term. Each Director will serve a three-year term, which expires on June 30th of the third year following the year of their election, and which may be renewed as many times as such Director is elected. Each Director shall hold office until that Director's term expires, or until his or her successor is elected, or until his or her earlier resignation, removal from office, or death. In order to create initial staggered terms, each initial director shall be assigned a term of one to three years. Each Director shall hold office until that Director's term expires, or until his or her successor is elected, or until his or her earlier resignation, removal from office, or death.

Section 3. Qualifications and Role of Directors. Once the Corporation becomes a public school, the Directors, in their capacity as Directors, shall be the Governing Board of a public Ohio community school. The Directors shall have a strong interest in the welfare of the Corporation and in education. Each Director should be willing and able to attend all meetings, both regular and special, and also be willing to accept special assignments and serve on committees.

Section 4. Nominations and Election of Directors. Candidates for Director shall be nominated by the Board of Directors or a committee thereof. At the annual meeting of Directors that is held on or before the date that such term expires, the Board of Directors shall elect a successor to any Director whose term is set to expire. The remaining Directors shall fill any vacancy in the Board of Directors created by the resignation, removal or death of a Director at a regular or special meeting of the Board of Directors. The remaining Directors shall have the

authority to fill any such vacancy despite the fact that the remaining Directors do not constitute a quorum. Candidates for Director may be nominated by any Director.

Section 5. Meetings. The annual meeting of the Directors shall be held in June of each year on such date, at such time, and at such place as a majority of the Directors may determine. In the event the Board of Directors is unable to hold its annual meeting in June, it shall hold such annual meeting on a date and at a time and place determined by a majority of the Directors. Special meetings may be called at any time by the President or by any two (2) Directors. Once the Corporation becomes a public school, meetings relating in any way to the business or operation of the public school must be open to the public and publicized or advertised as required by law.

Section 6. Quorum and Voting. The presence of a simple majority of the total number of Directors shall constitute a quorum for the transaction of business at all meetings of the Board of Directors. Except as otherwise provided by law, the Corporation's Articles of Incorporation, or this Code of Regulations, a vote of a simple majority of the Directors present at a meeting at which a quorum is present shall be required to effectuate action on all matters within the powers of the Board of Directors. In addition to those Directors who are actually present at a meeting, Directors shall for purposes of this section be deemed present and able to vote at such meeting if a conference telephone or similar communications equipment is used by means of which all persons participating in the meeting can communicate with each other at the same time. Provided however, once the Corporation becomes a public school, the Directors must be physically present at a meeting in order to be counted as part of a quorum and to vote, for so long as required by law.

Section 7. Notice and Waiver. Any notice required to be given by this Code shall be in writing and shall be delivered personally or sent by telegram, telecopy, or electronic mail transmission or by United States mail, express mail, or courier service, with postage or fees prepaid. For any notice made by personal delivery, telegram, telecopy or electronic mail, notice shall be deemed to be given when delivered or transmitted. For any notice sent by United States mail, or courier service, notice shall be deemed to be given when deposited in the mail or with the courier service. Unless waived in writing, notice of each annual meeting communicating the day, hour, and place shall be given to each Director by the Secretary of the Corporation not more than sixty (60) days nor less than three (3) days before any such meeting. Unless waived in writing, notice of each special meeting communicating the day, hour and place, and the purpose or purposes thereof shall be given to each Director by the Secretary of the Corporation not more than sixty (60) days nor less than three (3) days before any such meeting. Notice of the time, place and purposes of any meeting may be waived in writing, either before or after the holding of such meeting, by any Director, which writing shall be filed with or entered upon the records of the meeting. The attendance of any Director at a meeting without protesting, prior to or at the commencement of the meeting, shall waive notice or lack of proper notice for that meeting. Nothing in this Section 7 shall alter, however, the duty of the Corporation to provide notice to the public of meetings, once the Corporation becomes a public school. Notice to the public shall be given in accordance with Ohio law and pursuant to Board policy.

Section 8. Action by Written Consent. Any action required or permitted to be taken at any meeting of the Board of Directors or of any committee thereof may be taken without a meeting, if a written consent to such action is signed by all of the Board of Directors or all of such committee, as the case may be, and such written consent is filed with the minutes of proceedings of the Board of Directors or committee. Such a written consent may be signed by facsimile signatures which shall be construed as originals, and/or on separate but identical documents which shall be construed as one original. Provided however, if the Corporation is operating as a public school, all

action must be taken at open and public meetings and action by written consent shall not be allowed.

Section 9. Committees of Directors. The Board of Directors may create a committee or committees as the Directors may determine, the members of which committee or committees shall consist of not less than one (1) Director. A simple majority of the members of any such committee shall constitute a quorum, and the act of a simple majority of the votes cast at a meeting at which a quorum is present shall be the act of the committee. In every instance, however, the final action on all committee business shall only be a recommendation to the Board of Directors with respect to such matter. Notwithstanding anything to the contrary in this Section 9 however, once the Corporation becomes a public school, no committee nor any group of Directors, which consist of a majority of the Board of Directors, shall meet in a prearranged manner to discuss school business, without proper notice to the public of a regular or special meeting, and, only the votes of the Board of Directors shall be valid and binding.

Section 10. Other Advisory Councils. The Board of Directors may, at its discretion, also consider recommendations of associations, supporting organizations or advisory councils which are not part of the Board of Directors, such as those of parents or other pertinent groups.

Section 11. Removal of Directors. Any Director may be removed, with or without cause, at any time by the majority vote of the entire Board of Directors.

Section 12. Resignations and Vacancies. Any Director may resign by tendering a written resignation to the Board of Directors. The resignation shall be effective upon the date of receipt by the Board of Directors, or, if later, upon the date specified by the Director in his/her resignation. Vacancies in the Board of Directors shall be filled in accordance with Sections 4 of this Article III.

Section 13. Powers of Directors. The policies of the Corporation shall be directed by the Board of Directors in accordance with the law, and once the Corporation becomes a public school, also in accordance with the Corporation's community school contract and applicable laws. Subject to the provisions of Ohio law in general, the Ohio Nonprofit Corporation Law, the Articles of Incorporation and this Code of Regulations of the Corporation, the Board of Directors shall do and perform every act and thing whatsoever which it shall deem necessary, expedient or advisable to carry out the purposes of the Corporation.

Section 14. Honorary Directors. Any individual, whether an emeritus Director or not, who has provided extraordinary service to the Corporation over a period of time, may be honored with the title "Honorary Director," at the discretion of the Board. Honorary Directors are not voting members of the Board and are permitted but not required to attend meetings. The Board of Directors may remove an Honorary Director at any time, with or without cause, by a majority vote of the entire Board.

ARTICLE IV OFFICERS

Section 1. Number, Title and Election. The officers of the Corporation shall consist of a President, Vice President, Secretary, and Treasurer and may include such other officers and assistant officers as the Board of Directors shall deem advisable, each of whom shall be elected by the Board at the annual meeting of the Board. With the exception of the office of President, an

individual may simultaneously hold two offices. Officers shall hold office for a term of one year, or until their successors are elected and qualified, except in the event of their earlier death, resignation or removal.

Section 2. Vacancies. A vacancy in any office because of death, resignation or removal of an officer shall be filled by the Board of Directors for the unexpired term of such office.

Section 3. Resignation or Removal of Officers. An officer of the Corporation may resign at any time by tendering his or her resignation in writing to the Board of Directors and such resignation shall become effective immediately upon its delivery to the Board. An officer of the Corporation may be suspended or removed at any time, with or without cause, by the Board of Directors. The election or appointment of an officer for a term of office shall not be deemed to create employment or other contractual rights.

Section 4. President. The President shall preside at all meetings of the Board and shall coordinate the activities directed by the Board of Directors and shall oversee the actions and administration of the Corporation subject to the policies and goals established by the Board of Directors.

Section 5. Vice President. The Vice President shall perform the duties of the President when the President is absent, and all other duties as may be assigned by the Board of Directors.

Section 6. Secretary. The Secretary shall be responsible for providing notice of meetings to the Board of Directors where notice is required, and to the public for the matters concerning the public school, and shall keep a record of the proceedings of the Board of Directors, and shall perform other duties as may be required by the Board of Directors or the President. The Board of Directors may contract with a third party to carry out part or all of the Secretary's duties, pursuant to approval of the Board of Directors.

Section 7. Treasurer. The Treasurer shall act as the fiscal officer of the Corporation and shall have custody of the cash, securities, and other assets of the Corporation, shall receive contributions, bequests, revenues, and other assets to which the Corporation is entitled and disburse funds as directed by the Board of Directors, maintaining records thereof. The Treasurer shall maintain appropriate books of account and supporting records and shall prepare and file all returns and related reports required by federal and state statutes and regulations and by the Board of Directors. However, in all of the above responsibilities, subject to approval of the Board of Directors, the Board of Directors may contract with a third party to provide for all or part of the Treasurer's responsibilities. The Board may require a bond in any amount, at its discretion or as directed by law, and the cost of the bond or bonds shall be paid for by the Corporation.

ARTICLE V INDEMNIFICATION

Section 1. Indemnification of Directors, Officers, Employees and Agents. Each person who at any time is or shall have been a Director, officer, employee or agent of the Corporation, or a Director member of the Governing Authority of the school, and such person's heirs, executors and administrators, shall be indemnified by the Corporation, both during and after their association with the Corporation, for those acts or omissions concerning the Corporation, in accordance with and to the full extent permitted by the Nonprofit Corporation Law of the State of Ohio (Ohio

Revised Code Chapter 1702) as in effect at the time of the adoption of these Regulations or as amended from time to time thereafter. The foregoing right of indemnification shall not be deemed exclusive of other rights to which any Director, officer, employee, agent or other person may be entitled in any capacity as a matter of law or under any regulations, agreement, vote of Directors, or otherwise. As authorized by the Board of Directors, the Corporation may purchase and maintain insurance against liability on behalf of any such person to the full extent permitted by law in effect at the time of the adoption of these Regulations or as amended from time to time thereafter.

ARTICLE VI CONTRACTS BETWEEN CORPORATION AND RELATED PERSONS

Section 1. Limits on Contracts. To the greatest extent allowed by Ohio law and, while operating as public Ohio community school specifically subject to the limitations and restrictions imposed on public officers, any contract or other transaction between this Corporation and one or more of its Directors, or between this Corporation and any entity of which one or more of this Corporation's Directors are interested, whether such Director is a member of the Governing Authority of the school or not, shall be valid for all purposes, notwithstanding the presence of such Director at the meeting at which the Board of Directors of the Corporation acts upon, or in reference to, such contract or transaction, and notwithstanding the participation of the Director in such action, if the fact of such interest shall be disclosed or known to the Board of Directors, and the Board of Directors nevertheless, authorize, approve or ratify such contract or transaction by a vote of a majority of the Directors present. Unless Ohio law otherwise prohibits or permits, the interested Director may be counted in determining whether a quorum is present, but may not be counted in voting upon the matter or in calculating the majority of such quorum necessary to carry such vote. This Article shall not be construed to invalidate any contract or other transaction which would otherwise be valid under the common and statutory law applicable thereto.

ARTICLE VII BOOK AND RECORDS

Section 1. Records. The Corporation shall keep correct and complete books, records and minutes of the Board of Directors' meetings, and, during the time when the Corporation is functioning as a public school, such books and records shall be public records to the extent required by law. The Secretary of the Corporation shall keep an accurate list of the names and addresses of the Board of Directors.

ARTICLE VIII AMENDMENTS

Section 1. Amendments. The Code of Regulations shall be adopted and, from time to time, amended by a majority vote of the entire Board of Directors.

A. **General Ethical Behavior**. While serving on the Governing Authority, each Director agrees to:

1. Obey the law and follow and implement the School's policies;
2. Not disclose or use, without appropriate authorization, any information acquired in the course of the Director's duties that is privileged or confidential under the law;
3. Not speak or act for the Board unless granted proper authority;
4. Work with the Board to establish, review and revise effective policies;
5. Delegate authority for administration to School administrators/staff;
6. Make every effort to attend all Board meetings;
7. Become informed on issues before the Board and relating to Community Schools and school choice;
8. Debate matters before the Board, but once voted upon, accept and support the Board's decision; and
9. Act ethically and in conformance with the School's mission and goals.

B. **Public Officers Ethics and Conflicts Rules – Improper Influence or Use of Authority**.

Ohio law requires that all Board members and School officials, including teachers performing or possessing authority to perform administrative/supervisory functions, comply with these laws.

1. **Revised Code Section 102.03(D) & (E)**. A Board member cannot use, or authorize the use of, the authority or influence of his/her office or employment, or solicit or accept anything of value of such character as to manifest a substantial and improper influence upon him/her with respect to his/her duties.
 - a. "Anything of value" includes money and every other thing of value.
 - b. A thing of value has an improper character when it is secured from a party interested in matters before, or doing or seeking business with, the community school, its Board or employees, or where it could impair a Board member's objectivity and independence of judgment regarding his/her official actions and decisions.
 - c. A Board member shall not participate in matters that will benefit parties with whom he or she has a close family, economic, or business relationship.
 - d. **Abstain**. A Board member may avoid a conflict under R.C. 102.03(D) and (E) by abstaining from voting and refraining from discussions or deliberations of the Board regarding the matter. The Board shall follow the procedures set forth in Part E of this policy when presented with a transaction to which R.C. 102.03(D) or (E) applies.

2. Revised Code Section 2921.42(A)(1). A Board member cannot authorize or employ the influence of his/her office to secure authorization of any public contract in which he/she, a member of his/her family, or any of his/her business associates has an interest.
 - a. A prohibited interest must be direct and definite and may be either pecuniary or fiduciary in nature.
 - b. **Abstain**. A Board member may avoid a conflict under R.C. 2921.42(A)(1) by abstaining from voting and refraining from discussions or deliberations of the Board regarding the matter. The Board shall follow the procedures of Part D of this policy when considering a situation involving R.C. 2921.42(A)(1).
3. Revised Code Section 2921.42(A)(3). A Board member shall not occupy any position of profit in the prosecution of a public contract which she or the community school board authorized, and which was not let by competitive bidding to the lowest and best bidder while the Board member holds a position on the Board or within one year thereafter.
 - a. A Board member occupies a position of profit in a public contract whenever he/she will receive a fee or compensation that is paid from or is dependent upon the contract, or the Board member will receive some other profit or benefit from the contract.
 - b. **Abstention** will not cure an R.C. 2921.42(A)(3) conflict.
4. Revised Code Section 2921.42(A)(4). A Board member cannot have an interest in the profits or benefits of a public contract entered into by or for the use of the community school.
 - a. A Board member has a prohibited interest in the profits or benefits of a public contract if the Board member would financially benefit from the contract, or the Board member has an ownership or fiduciary interest in the entity that is entering into the contract, unless the exception in R.C. 2921.42(C) applies.
 - b. For the exception to apply pursuant to R.C. 2921.42(C), the subject of the contract must be necessary supplies or services for the community school, and the supplies or services must be unobtainable elsewhere for the same or lower cost, or be furnished to the community school as part of a continuing course of dealing established prior to the Board member becoming associated with the community school, and, treatment of the community school must either be preferential to or the same as that accorded to other customers in a similar transaction. Under the exception, the entire transaction conducted at "arms-length" with the Board's full knowledge of the Board member's interest.
 - c. Abstention will not cure an R.C. 2921.42(A)(4) conflict unless the exception in R.C. 2921.42(C) applies.
5. Revised Code Section 2921.43(A). No public servant may knowingly solicit or accept improper compensation (a) other than as allowed by R.C. 102.03 (G), (H) and (I), to perform their acts, duties or services in their public servant capacity or as a supplement thereof, or, (b) for any additional or greater fees or costs than allowed by law in order to perform their official duties;
6. Revised Code Section 2921.43(B). No public servant shall solicit or accept anything of value for their own personal or business use or for the business or personal use of another

public servant or party official, in consideration for (a) appointing, securing, maintaining, or renewing the appointment of any person to public office, employment or agency, or, (b) preferring or maintaining a public employee's compensation, duties, placement, location, promotion or other material aspect of employment. A person is not prohibited from making voluntary contributions.

7. Revised Code 2921.43(C). No person shall coerce any contribution for the benefit of a political party, campaign committee, legislative campaign fund, political action committee or political contributing entity, in consideration for (a) appointing, securing, maintaining or renewing the appointment of any person to any public office, employment or agency, or (b) preferring or maintaining the status of any public employee's compensation, duties, placement, location, promotion or other material aspects of employment. Coercion need not actually cause or prohibit any action from actually occurring. A person is not prohibited from making voluntary contributions.
8. Revised Code Section 2921.44. A fiscal officer shall be disqualified from serving as a public official for four years after being found guilty of dereliction of duty in Ohio and, also prohibited from holding a public office until all restitution or repayment required by a court has been satisfied. Dereliction of duty may include (a) recklessly creating a deficiency, incurring a liability, or expending a greater sum than is appropriated by the general assembly for the use in any one year for the entity to which the public official is connected; or, (b) recklessly failing to perform a duty expressly imposed or forbidden by law with respect to the public servant's office.

C. **Excess Benefit Transaction**. Internal Revenue Code Section 4958 provides for an excise tax that is imposed on a "disqualified person" who enters into an "excess benefit transaction" with the School. The tax may be imposed on members of management who approve the transaction. A transaction is an "excess benefit transaction" if the School pays more than fair market value for goods or services.

1. "Disqualified person" includes:

- a. A person in a position to exercise substantial influence over the affairs of the School at any time during a five year period ending on the date of the transaction;
- b. A member of the family of a person described in a, above;
- c. A corporation or other entity in which persons described in a and b, above, have a 35% or greater voting or ownership interest; and
- d. Any person having a relationship described in a, b, or c above with a company that has contracted to manage the School.

D. **IRC Procedure for Matters Involving Conflicts**. The Board shall follow the following procedures when it is called upon to consider any matter with respect to which an "interested person" has a "financial interest" as those terms are defined below. Please note: the fact that the Board of Directors has followed the procedures set forth below will not enable an "interested person" to avoid the legal prohibitions of R.C. 2921.42(A)(3) and (4) discussed in Parts B.3 and B.4, above.

1. For purposes of these procedures the following words have the following definitions.

- a. An "interested person" is any Board member, principal officer, or member of a committee with governing board delegated powers, who has a direct or indirect financial interest, as defined below.
 - b. A person has a "financial interest" if the person, directly or indirectly, through business, investment, or family has:
 - i. An ownership or investment interest in any entity with which the School has a transaction or arrangement;
 - ii. A compensation arrangement with the School or with any entity or individual with which the School has a transaction or arrangement; or
 - iii. A potential ownership or investment interest in, or compensation arrangement with, any entity or individual with which the School is negotiating a transaction or arrangement.
 - c. "Compensation" includes direct and indirect remuneration as well as gifts or favors that are not insubstantial.
2. Duty to Disclose. In connection with any actual or possible conflict of interest, an interested person must disclose the existence of the financial interest and be given the opportunity to disclose all material facts to the Board members and members of committees with governing board delegated powers considering the proposed transaction or arrangement.
3. Determining Whether a Conflict of Interest Exists. A financial interest is not necessarily a conflict of interest. Under this procedure, a person who has a financial interest will have a conflict of interest only if the appropriate governing board or committee decides that a conflict of interest exists. Please note: the situations described in Part B present a conflict of interest. As such, the Board need not determine whether a conflict exists for any situation described in Part B. If the situation is not described in Part B, after disclosure of the financial interest and all material facts, and after any discussion with the interested person that is permitted under these policies, he/she shall leave the Board or committee meeting while the determination of a conflict of interest is discussed and voted upon. The remaining Board or committee members shall decide if a conflict of interest exists.
4. Procedures for Addressing the Conflict of Interest.
- a. Except as otherwise provided in these policies, an interested person may make a presentation at the governing board or committee meeting, but after the presentation permitted under these policies, he/she shall leave the meeting during the discussion of, and the vote on, the transaction or arrangement involving the possible conflict of interest.
 - b. The chairperson of the governing board or committee shall, if appropriate, appoint a disinterested person or committee to investigate alternatives to the proposed transaction or arrangement.
 - c. After exercising due diligence, the governing board or committee shall determine whether the School can obtain with reasonable efforts a more advantageous

transaction or arrangement from a person or entity that would not give rise to a conflict of interest.

- d. If a more advantageous transaction or arrangement is not reasonably possible under circumstances not producing a conflict of interest, the governing board or committee shall determine by a majority vote of the disinterested Board members whether the transaction or arrangement is in the School's best interest, for its own benefit, and whether it is fair and reasonable. In conformity with the above determination it shall make its decision as to whether to enter into the transaction or arrangement.

E. Other Procedures and Record Keeping Requirements.

1. Violations of the Conflicts of Interest Policy.
 - a. If the Board or committee has reasonable cause to believe a member has failed to disclose an actual or possible conflict of interest, it shall inform the member of the basis for such belief and afford the member an opportunity to explain the alleged failure to disclose.
 - b. If, after hearing the member's response and after making further investigation as warranted by the circumstances, the governing board or committee determines the member has failed to disclose an actual or possible conflict of interest, it shall take appropriate disciplinary and corrective action.
2. Documentation. The minutes of the Board and all committees with board- delegated powers shall contain:
 - a. The names of the persons who disclosed or otherwise were found to have a financial interest in connection with an actual or possible conflict of interest, the nature of the financial interest, any action taken to determine whether a conflict of interest was present, and the Board's or committee's decision as to whether a conflict of interest in fact existed.
 - b. The names of the persons who were present for discussions and votes relating to the transaction or arrangement, the content of the discussion, including any alternatives to the proposed transaction or arrangement, and a record of any votes taken in connection with the proceedings.
3. Annual Statements. Each Board member, principal officer and member of a committee with governing board delegated powers shall annually sign a statement which affirms such person:
 - a. Received a copy of the conflict of interest policy;
 - b. Read and understands the policy;
 - c. Agreed to comply with the policy;
 - d. Understands the School is charitable and must engage primarily in activities which accomplish one or more of its tax-exempt purposes to maintain its federal tax exemption;

- e. Acknowledges that a voting Board member who receives compensation, directly or indirectly, from the School for services is precluded from voting on matters pertaining to that member's compensation;
 - f. Acknowledges that a voting committee member whose jurisdiction includes compensation matters and who receives compensation, directly or indirectly, from the School for services is precluded from voting on matters pertaining to that member's compensation; and
 - g. Acknowledges that no voting member of the Board or any committee whose jurisdiction includes compensation matters and who receives compensation, directly or indirectly, from the School, either individually or collectively, is prohibited from providing information to any committee regarding compensation.
4. Periodic Reviews. To ensure the School operates in a manner consistent with its charitable purposes and does not engage in activities that could jeopardize its tax-exempt status, periodic reviews shall be conducted. The periodic reviews shall, at a minimum, include the following subjects:
- a. Whether compensation arrangements and benefits are reasonable, based on competent survey information, and the result of arm's length bargaining.
 - b. Whether partnerships, joint ventures, and arrangements with management companies conform to the School's written policies, are properly recorded, are a reasonable investment or a reasonable payment for goods and services, further its charitable purposes and do not result in inurement, impermissible private benefit, or an excess benefit transaction.
5. Use of Outside Experts. The School may use outside experts in conducting its reviews, but, such use does not relieve the Board's obligation to conduct periodic reviews.
6. Immediate Relatives. An "immediate relative" means the Board member's spouse, children, parents, grandparents, and siblings, as well as in-laws residing in the same household as the Board member.
- a. If the School is not sponsored by a school district or educational service center, no present or former Board member, or immediate relative of any present or former Board member, shall be an owner, employee, or consultant of the School's sponsor or operator, unless at least one year has elapsed since the person's Board membership ceased.
 - b. If the School is sponsored by a school district or educational service center, no present or former Board member, or immediate relative of any present or former Board member, shall (i) be an officer of the Sponsor's governing board, unless at least one year has elapsed since the person's Board membership ceased, or (ii) serve as an employee of or consultant for the department, division, or section of the Sponsor organization that is directly responsible for sponsoring community schools, or have supervisory authority over such a department, division, or section, unless at least one year has elapsed since the person's Board membership ceased.
7. Annual Disclosure Requirement. Each Board member shall annually file a disclosure statement setting forth the names of any immediate relatives or business associates

employed, within the previous three (3) years, by (a) the sponsor or operator of the School, (b) a school district or educational service center that has contracted with the School, or (c) a vendor that is or has engaged in business with the School.

Each Governing Authority Director (Board member) shall sign a copy of this Ethics and Conflicts Policy in order to demonstrate his/her commitment to these principles.

Signature and Title

Date

Note: All School officials and employees, including teachers who do perform or who have the authority to perform administrative and supervisory functions, are subject to all Ohio Ethics and Conflicts Laws and should sign the above acknowledgment as well.

Ohio Revised Code Chapter 102, Sections 2921.42, 2921.43, 2921.44 and 3314.02.

Adopted: _____

9/25/17

Reimbursement

A Board member may receive reimbursement only for expenses that are pre-approved by the Board.

The following guidelines have been established by the Board to ensure appropriate and proper reimbursement of expenses for Board members.

Expenses will be reimbursed only for activities authorized by the Board at a rate determined by the Board.

When attending a Board-approved conference, fees, parking, mileage, meals, and housing which are reasonable can be submitted for approval, including a maximum gratuity of twenty percent (20%). A Board member will not be reimbursed for any upgrades for example, a hotel room with a view, or for room service.

A Board member cannot be reimbursed for any expense if the Board member received a benefit through a rewards program for that expense. Rewards programs allow users to earn rewards based on how much money they spend. Examples of rewards programs include, but are not limited to, frequent flier miles, grocery store loyalty card programs, and hotel free night programs. This prohibition includes rewards programs tied to credit cards and loyalty customer cards. No entertainment expenses or purchases of alcoholic beverages are reimbursable.

A voucher detailing the amount and nature of each expense must be submitted to the Board for approval within ten (10) days after the expenses have been incurred.

Compensation Procedures

The Board and any compensation committee will follow these procedures in reviewing compensation arrangements with Board members, officers, and employees:

- a. Approve all compensation arrangements in advance (before paid).
- b. Document (in writing) its terms and the date approved.
- c. Document (in writing) the decision made by each member who participated in process.
- d. When warranted, consider compensation surveys and compensation paid or offered by similarly situated entities for similar services.
- e. Document (in writing) the information considered in making the decision, and its source.

The Board hereby approves does not approve [check one] compensation of \$_____ per meeting attended (no more than \$125 per meeting attended) for each community school Board member to be effective at the end of his or her term, for his or her next term.

The Board hereby approves does not approve [check one] compensation of \$ _____ for attendance at an approved training program three hours or less in length (no more than \$60 per day). The Board hereby approves does not approve [check one] compensation of \$ _____ for attendance at an approved training program over three hours in length (no more than \$125 per day).

No Board member shall be compensated more than a total amount of \$5,000 per year for all Ohio community school governing authorities on which the individual serves.

R.C. 3314.02; Ohio Ethics Comm. Advisory Opinion No. 91-010

The Edge Academy/Akros Middle School

Board of Directors

2019-2020

Name	Title	School Business Email	Phone Number	Address
Staci Nevels	President	snevels@edge4kids.org	330-858-4534	834 Bellevue Ave. Akron, Ohio 44314
Dr. Mary Beth Kluge	Director	mbkluge@edge4kids.org	330-869-5447	844 Knights Bridge Rd. Akron, Ohio 44313
Richard Schwarz	Director	dschwarz@edg4kids.org	330-253-5912	39 South Main St. Ste 606 Akron, Ohio 44308
Donna Ryckman	Director	dryckman@edge4kids.org	330-929-9203	688 Brookpark Drive Cuyahoga Falls, Ohio 44223
Ian Taylor	Director	itaylor@edge4kids.org	330-690-7571	211 Portage Path Apt 404 Akron, Ohio 44303

148.1 Purchasing/Invoicing

Before placing a purchase order, each party authorized to place a purchase order should consider whether the material requested may be available elsewhere in the School or in the management company network. In the interests of economy, fairness and efficiency, the Board requires that:

- A. All purchase orders shall be numbered consecutively.
- B. An informal but documented assessment of the responsibility, reliability, comparative cost and reputation of available qualified suppliers shall have been conducted before the purchase order is submitted.
- C. Certain purchases may be below an amount of money allowed to be spent without a properly signed purchase order, as authorized by the management company and the Principal.
- D. Insofar as conditions permit, all legitimate business suppliers shall be treated courteously.
- E. Credit card agreements may be approved by the Principal and the management company, at their sole but joint discretion, and, if so approved, all credit cards shall be kept in the custody of the Principal in a locked area. All credit card purchases require the prior written approval of the Principal and the director. Any staff member or Board member entrusted with a credit card shall be personally liable for the proper use and safekeeping of the credit card.
- F. Cooperative purchasing among schools managed by the same company is encouraged, if it results in an economic advantage. Other cooperative purchasing may be considered as well.
- G. If it results in an advantage of any kind, the School may prefer local vendors.
- H. All applicable ethical and conflicts rules shall be followed when purchasing or soliciting for purchasing. No director, officer, employee, staff or agent of the School shall 1) solicit or participate in the negotiations of a contract in which he or she has any direct or indirect pecuniary or beneficial interests or 2) accept any gift or favor from a vendor which might influence their recommendations in the eventual purchases of equipment, supplies or services.

These policies do not prevent any person from receiving royalties upon the sale of any textbook or similar educational product of which she or he is the author, which has been properly approved for use in the School.

If the Board is presented with an invoice from a vendor, the vendor must certify that the good or services were used for School purposes, the invoice must contain sufficient itemization to determine that the services or goods were used for School purposes and the fiscal agent or fiscal officer of the School shall pre-approve payment before the invoice is approved by the Board.

R.C. 102.03; OAC 117-2-02

See also Policy No. 395.1 Purchase of Supplies and Materials, Equipment. See also Policy No. 148.6 Credit Cards.

148.10 Cost Principles and Financial Management for Use of Federal Funds

Federal grant awards will be administered efficiently and effectively through the application of sound management practices consistent with federal, state, and local laws, including the federal Uniform Grant Guidance, and any underlying grant agreements.

Financial Management

Grant funds must be managed in compliance with all applicable federal, state and local laws and rules as well as the terms of any federal grant award.

The School shall do all of the following:

1. Identify in its accounts all federal award funds received and expended and shall specify the federal program under which those awards were received. Whenever applicable information is available, accounts must include the Catalog of Federal Domestic Assistance ("CFDA") title and number, the federal award identification number and year, the name of the awarding federal agency, and the name of the pass-through entity.
2. Make accurate, current and complete disclosures of the financial results of each federal grant award as required by the terms the award.
3. Maintain records that adequately identify the source and application of funds used for federally funded activities. Records must contain information about the awards, authorizations, obligations, unobligated balances, assets, expenditures, income and interest and shall be supported by source documentation.
4. Exercise control over and accountability for all funds, property and other assets purchased with federal funds. All assets shall be safeguarded and the School shall assure that they are used only for authorized purposes.
5. Regularly compare expenditures with budget amounts for each federal award.

Cost Principles

All costs must conform to any limitations or exclusions set forth in the federal award. Costs must be accorded consistent treatment. The School shall only assign a cost to a federal award as a direct cost when no other cost incurred for the same purpose in like circumstances has been allocated as an indirect cost. Costs shall not be included to meet cost sharing or matching requirements of any other federally-financed program in either the current or a prior period.

Costs shall be determined in accordance with generally accepted accounting principles ("GAAP") and shall be consistent with policies and procedures that apply uniformly to both federally-financed and non-federally financed activities.

All costs must be adequately documented and shall be necessary, reasonable and allocable to the performance and administration of the relevant federal award. A cost must be allocable to a particular federal award or other cost objective if the goods or services in accordance with relative benefits received.

Date Adopted: 9/16/19

Costs must be reasonable in both the nature and amount. The following shall be considered when to determine if a cost is reasonable:

1. Whether the cost is a type recognized as ordinary and necessary for the School's operation or for the proper and efficient performance of the federal award;
2. Applicable restraints imposed on the cost, including sound business practices, arm's-length bargaining, relevant federal and state laws and rules, and terms and conditions of the awards;
3. Market prices for comparable goods and services for the geographical area;
4. Whether individuals authorizing the cost acted prudently when considering the costs; and
5. Whether the cost amounts to a significant deviation from established School practices that may unjustifiably increase costs.

Payments

Methods of payments utilized by the School must minimize the time elapsing between the transfers of funds to and from vendors. Any funds drawn in advance must be as close in time to the actual related expenditure as feasible.

Compensation

Employee or contractor compensation, including wages, salaries and fringe benefits, shall be permitted to the extent that:

1. The rate of compensation is reasonably consistent with (a) compensation paid for similar work in other activities by School employees or contractors, if any, or (b) compensation for similar work in the labor market; and
2. Compensation is supported by records that accurately reflect the work performed.

The School shall comply with all requirements to document the time and effort of personnel whose compensation is funded in whole or in part using federal grant funds. Reports must provide reasonable assurances that personnel charges are accurate, allowable and properly allocated. Time and effort reports shall be maintained by the School and shall comply with the School's established accounting practices.

Travel payment and reimbursement provided from federal funds must include documentation that demonstrates that the participation of the individual is necessary to the federal award and the costs are reasonable and consistent with the School's policies.

Uniform Grant Guidance, 2 C.F.R. 200 et seq.; 2 C.F.R. 200.302; 2 C.F.R. 200.305; 2 C.F.R. 200.430; 2 C.F.R. 200.431.

See also Policy 148.2 Fixed Asset Policy/ Title I and Federal Grant Asset Policy and Policy 148.8 Federal Grants Procurement, Monitoring, and Administration.

148.2 Fixed Asset Policy/Title Assets Policy

A. Purpose

The School's fixed asset/Title I policy establishes a fixed asset accounting system that, if followed, will ensure that the School properly handles and disposes of assets, including those assets obtained with Title I grant monies and contains sufficient data to permit:

1. the preparation of fiscal year-end financial statements in accordance with Generally Accepted Accounting Principles (GAAP);
2. adequate insurance coverage; and
3. control, accountability and security.

Criteria for Fixed Asset Capitalization

An item is a Fixed Asset if:

1. it has a useful life of one (1) year or more, and
2. the cost of the asset is greater than \$1,500.00, or, it is a leased asset with a purchase price of greater than \$1,500.00.

Valuation

Fixed assets are to be valued at historical cost or, if that amount is not practicably determined, at estimated historical cost. The Controller shall determine the estimated historical cost.

Donated fixed assets shall be valued at the donor's estimated fair market value at the time of gifting.

Depreciation

Assets will be depreciated using straight-line depreciation. Estimated life for fixed assets shall follow ASBO (Association of School Business Officials) guidelines.

Classifications:

Fixed assets shall be classified as follows:

1. furniture
2. equipment
3. leased fixed assets
4. real property

Information

The following information shall be maintained for all fixed assets:

1. description of the asset
2. who holds title to the property
3. serial number of the asset

4. asset classification
5. location, use, and condition of the asset
6. purchase price and percentage of federal participation
7. vendor
8. date purchased or leased
9. accumulated depreciation
10. date and method of disposal and sale price
11. records generated by physical inventories

Management of Fixed Assets

The School shall conduct a physical inventory of its fixed assets no less frequently than every two years. The results of the physical inventories must be reconciled with the property records.

The School shall develop a control system to safeguard against loss, damage, or theft of fixed assets. The School shall investigate any loss, damage, or theft of any fixed asset.

In order to prevent loss or theft of School property, all fixed assets (other than real property) will have a School fixed asset sticker.

The School shall maintain its fixed assets in order to keep them in good condition and working order.

The School shall establish and follow procedures to ensure that it receives the overall best possible return, if it sells any fixed asset. An independent valuation or market comparison may be used, among any other reasonable method of valuation.

Real Property Acquired with Title I Grants

Real property acquired with federal Title I grant monies received by the School shall be titled in the name of the School.

Real property acquired with federal Title I grant monies shall be used for the purposes authorized by the grant(s).

The School shall not transfer or encumber its title or other interest in any real property acquired with federal Title I grant monies.

Equipment Acquired with Title I Grants

Equipment acquired with federal Title I grant monies received by the School shall be titled in the name of the School.

For as long as needed, the School shall use equipment acquired with federal Title I grant monies in the program or project for which it was acquired, whether or not the project or program continues to be supported by federal funds. The equipment may be used in other activities currently or previously supported by a federal agency when it is no longer needed for the program or project for which it was acquired.

The School can use equipment acquired with federal Title I grant monies on other projects or programs that are currently or were previously supported by the Federal Government provided that such use will not interfere with the program or project for which the equipment was acquired. First preference should be given to other programs or projects supported by the agency that awarded the grant monies.

The School shall not use the equipment acquired with federal Title I grant monies to provide services for a fee.

The School shall obtain the approval of the awarding agency before it (1) uses equipment acquired with federal Title I grant monies as a trade-in to acquire equipment to replace the old equipment, or (2) sells the old equipment and uses the sale proceeds to offset the cost of the replacement equipment.

Equipment Furnished by Federal Agency

The School shall ensure that the equipment remains titled in the name of the Federal Government.

The School shall follow the rules and procedures of the federal agency for managing the property.

Disposal of Fixed Assets not Acquired with Title I or Federal Grant Funds

Fixed assets that were not acquired in whole or part with federal grant monies will be disposed in a manner approved by the School Board. Upon recommendation of the Head of School or Treasurer, such Board resolution shall designate the materials, equipment, supplies or other assets as obsolete, excess or unusable, and, shall identify the assets, and may sell, donate or lawfully dispose of them. Any proceeds shall be put in the general fund.

Disposal of Fixed Assets Acquired with Title I or Federal Grant Funds

Real Property. When real property acquired with federal grant monies is no longer used for the originally authorized purpose(s), the School shall dispose of such property pursuant to instructions provided by the awarding agency.

Equipment. The School may retain, sell or otherwise dispose of equipment acquired with federal funds. However, the School shall contact the awarding agency for disposition instructions before it sells any equipment with a per unit value of greater than \$5,000 because the awarding agency may have a right to a portion of the proceeds of the sale. State law may dictate the procedures that must be followed or otherwise place restrictions on the ability of the School to sell the property.

Disposal of Equipment Provided by a Federal Agency

The School shall only dispose of federal equipment pursuant to instructions provided by the federal agency that provided the equipment, or should the assets or equipment be under a value or value per unit as applicable under the rules of the federal agency, then the School may dispose of the equipment or asset as if it was not acquired with federal grant funds.

34 CFR Sections 80.31 and 80.32

See also Policy No. 148.8 Federal Grants Procurement, Monitoring and Administration.

148.3 **Audit Committee**

The Board shall establish an audit committee which shall consist of one of the following: the entire Board membership, or, a minority of the Board membership, or, a minority of the Board membership and any outside consultants of the Board's choice. At least one member of the audit committee shall possess knowledge in the areas of accounting, auditing, financial reporting or school finance. The audit committee shall serve a one-year term and meet as often as necessary to carry out its responsibilities. Members of the audit committee shall attend to their responsibilities in good faith, and in a manner they reasonably believe to be in the best interests of the School.

The purpose of the audit committee is to ensure that both external and internal audit functions and other accountability issues receive adequate oversight. The audit committee's responsibilities include, but are not necessarily limited to, a review of the annual unaudited financial reports submitted to the Auditor of State; a periodic review of the interim financial information submitted to the Board; a review of all audit results; an assurance that audit recommendations are appropriately addressed; serving as a liaison between School management and the independent auditors. Any recommendations of the audit committee shall be presented to the Board and responsibility for official action remains with the Board.

OAC 117-2-05

148.4 Independent Contractors

For purposes of this policy, independent contractors are individuals who provide services to the School who are not treated as employees of the School for purposes of withholding federal employment and income taxes.

The School may contract with an independent contractor for a service if none of the School's employees are qualified to provide the service, or, if having Employees perform the service would interfere with the daily operations of the School, or, if the Board of Directors of the School or its authorized designee deems it in the best interest of the School.

The School shall maintain a list of the independent contractors with whom it has contracted.

To the extent required by law, the School shall issue a 1099 Form to each independent contractor reporting the amount paid to the contractor and file the form with the appropriate governmental agency(ies).

In contracting for services with any independent contractor, the School shall enter into a written contract on or before the date the independent contractor begins to provide services under the contract if the amount payable under the contract is \$600.00 or more. The contract shall specifically describe the services that the independent contractor will provide under the contract.

The School shall obtain a W-9 form from the independent contractor at the time the contract is executed.

Subject to the terms of the contract, the School shall require that the independent contractor substantiate that the services have been performed before the School shall remit payment for the services.

No independent contractor shall be paid as an employee on a W-2 form. If any state retirement system decides that School must pay into its system on behalf of a contractor, such funds will be deducted from the gross pay to the contractor.

All employees of independent contractors providing "essential school services" to the School must fulfill one of the following conditions:

1. The independent contractor has provided proof that it has requested a criminal records check, including an FBI check, within the five-year period prior to the date on which the person will begin working in the School and the records check indicated that the person had not been convicted of or pleaded guilty to an offense that would disqualify the person for employment with the School;

OR

2. During periods of time when the employee of the independent contractor will have routine interaction with a child or regular responsibility for the care, custody or control of a child, an employee of the School has been assigned to be present in the same room as the child or, if outdoors, to be within a 30-yard radius of the child or to have visual contact with the child.

The School's Principal or his/her designee is responsible for ensuring that employees of independent contractors have successfully completed a criminal records check or will be supervised when they have access to children.

The Principal has specified that "essential school services" are necessary services that would need to be provided by Employees if the services were not provided by an independent contractor (such as food, janitorial or clerical services).

IRC 6041; R.C. 3314.41

148.5 Annual Financial Report

The School shall file an annual financial report, which must be prepared using generally accepted accounting principles. The report must contain the following:

1. The amount of collections and receipts, and accounts due from each source;
2. The amount of expenditures for each purpose;
3. The income of each public service industry owned or operated by a municipal corporation, and the cost of such ownership or operation (if applicable); and
4. The amount of public debt of each taxing district, the purpose for which each item of such debt was created, and the provision made for the payment thereof (if applicable).

The School must prepare two copies of the report. The original must be filed with the auditor of state at "Auditor of State, Local Government Services Division, 88 East Broad Street, Columbus, Ohio 43216-1140", or "Post Office Box 1140, Columbus, Ohio 43216-1140" and the copy must be retained by the School's fiscal officer. The report must be filed either in paper form or electronically in a manner and format prescribed by the auditor of state and must be filed within one hundred and fifty days after the close of the fiscal year. At the time the report is filed with the auditor of state, the School's chief fiscal officer, must publish notice in a newspaper of general circulation in the political subdivision or taxing district.

R.C. 117.38; OAC 117-2-03.

148.6

Credit Cards

For purposes of this policy, "credit cards" are defined to include any bank- or financial institution-issued credit card account, store-issued credit card account, affinity credit card account, or any other credit card account allowing the holder to purchase goods or services on credit, or any debit or gift card account related to the receipt of grant money. The Board recognizes the convenience and efficiency afforded by the use of School credit cards. A credit card shall not be used in order to circumvent the general purchasing procedures established by State law and Board policy. The Board affirms that credit cards shall only be used in connection with Board-approved or School-related activities and that only those types of expenses that are for the benefit of the School and serve a valid and proper public purpose shall be paid for by credit card. As such, employees are required to abide by the following guidelines when using a School credit card.

1. All credit cards and any instruments related to the account, including checks, shall be applied for, acquired, or cancelled at the direction of the Board and shall be issued to and in the name of the School. Any changes to credit card terms requiring consumer authorization, including changes to credit limits, shall be approved by the Board.
2. Upon issuance, all credit cards and instruments related to the account shall be managed, held and supervised by the Principal, who shall be the School's credit card compliance officer and shall be prohibited from authorizing the use of the credit card by any other individual OR the designated fiscal officer [Choose one] ("Credit Card Holder").
3. The Board may authorize any employee to use a credit card when the Board deems such use necessary or convenient, irrespective of who the Credit Card Holder is.
4. Subject to the discretion of and the approval of the Board, credit cards may be used for eligible goods and services including:
 - a. Transportation reservations and expenses.
 - b. Conference registrations.
 - c. Hotel reservation guarantees and expenses.
 - d. If monies are budgeted and deposited with the Principal in advance, credit cards may be used by employees for student trips and competitions for safety and security reasons.
 - e. Reasonable real expenses, including a maximum gratuity of twenty percent (20%), but excluding alcoholic beverages, since the purchase of such beverages clearly fails to serve a valid and proper public purpose.
 - f. Purchases from vendors who do not accept purchase orders or vouchers, with prior approval from the Board.
 - g. Other purchases approved by the Board on a case-by-case basis.
5. Credit cards shall not be used for personal purchases or expenditures not allowed under this guideline. In particular, credit cards shall not be used for expenses that are not incurred in connection with Board-approved or School-related activities, are not for the benefit of the School, and do not serve a valid and proper public purpose. Use of credit cards in an unauthorized or

illegal manner may result in referral for criminal prosecution, revocation of credit card privileges, disciplinary action and/or, where appropriate, may require the user to pay any and all inappropriate charges, including finance charges and interest assessed in connection with the purchase.

6. The Board shall establish limits on the total dollar amount that an employee may incur as a part of any individual transaction based on a good faith estimate of the purchase or expense. If the designated fiscal officer is the Credit Card Holder, the fiscal officer shall establish limits on the total dollar amount that an employee may incur as a part of any individual transaction based on a good faith estimate of the purchase or expense, which shall be approved and ratified by the Board.
7. Employees requiring the use of a School credit card shall request in writing such card from the Board or the designated fiscal officer if he or she is the Credit Card Holder, which shall include a signed statement that the requesting employee has read this policy, and understands and agrees to abide by its terms.
8. The School is a nonprofit instrumentality of the State of Ohio. Tax exemption forms shall be utilized and are available in the Principal's office.
9. Upon receipt of a School credit card, employees shall:
 - a. Inform merchants that the purchase is for "Official School Business" and is not subject to State or local sales tax. However, if the merchant fails to waive the tax, the employee shall pay it. For large purchases where the merchant refuses to waive the tax, the employee shall present a tax exemption form.
 - b. Maintain credit cards in a secure fashion and prevent unauthorized charges to the account.
 - c. Maintain sufficient documentation of all purchases, including, but not limited to, charge receipts, original cash register slip or other detailed receipt, and invoices.
 - d. Provide documentation of all purchases to the Credit Card Holder in a timely manner to ensure prompt payment.
 - e. Immediately notify his or her immediate supervisor, the Credit Card Holder, and the Board if the card is lost or stolen. It shall be the responsibility of the Principal to report any lost or stolen credit card to the relevant issuer and credit agencies. In the event that a credit card is lost or stolen, the Principal shall request that the issuer place a "stop" or "hold" on the account to prevent fraudulent use of the card.
 - f. After use, School credit cards are to be returned to the Credit Card Holder, along with appropriate itemized receipt copies of all charges. If the Principal is the designated credit card compliance officer, the Principal shall review all itemized receipts and submit copies to the School's fiscal officer or his or her designee.
 - g. Upon receipt of the appropriate documentation, credit card expenditures will be paid through the Credit Card Holder's Office.
 - h. The Credit Card Holder will monitor the credit card account(s) and reconcile all credit card accounts on a monthly basis. A report will be a part of the monthly Cash Activity Report reported to the Board, and if the Principal is the Credit Card Holder, the Board shall sign a

monthly attestation indicating that it has reviewed the account transaction details.

- i. At least quarterly, the Board and the Credit Card Holder shall review the number of credit card accounts and the number of active credit cards in use, and each credit card's respectively expiration date and credit limit.
 - j. If the employee is terminated or resigns, he or she must return the credit card and shall remain responsible for any inappropriate use.
10. Failure to turn in receipts and appropriate forms to the Credit Card Holder within five (5) business days may result in the charges being deemed unrelated or unsubstantiated. This amount will then be charged back to the user.
 11. Credit Cards shall never be used for any cash withdrawal transactions or advances from a financial transaction device or automated teller machine ("ATM"), or to obtain any cash back on a credit card transaction.
 12. The designated fiscal officer shall annually report to the Board any rewards received by the School based on the School's use of the credit card.

R.C. 3314.52.

See also Policy 148.1 Purchasing/Invoicing.

148.7 Staff Reimbursement

Expenses which are incurred by professional staff members as a result of authorized travel for the School will be reimbursed to the extent provided for in these guidelines. Reimbursement is intended to provide for transportation, lodging, and food of reasonable and adequate quality. When traveling on School business, a professional Staff member is expected to use the same care in incurring expenses that a prudent person would exercise if traveling on personal business, and reasonable efforts will be made to reimburse actual expenses. Excessive costs, such as those caused by circuitous routes or luxury services or accommodations, will not be considered prudent, nor will they be accepted for reimbursement. No charges for alcoholic drinks will be reimbursed. Rental cars must be economy rentals unless approved in advance by the Treasurer as otherwise necessary or prudent.

Authorization and Procedure: When travel is expected, a requisition form should be completed and approved by the Superintendent at least ten (10) days prior to the date a decision is needed. This request should detail all estimated expenditures.

Reimbursement: Reimbursement will be at the current approved IRS rate if driving on School business. If transporting students to competition or trips, Staff volunteers will be reimbursed actual expenses, documented by receipt, or at the IRS Approved Charitable Rate.

A Travel Reimbursement Form must be completed and signed by a supervisor. All claims must be supported by original receipted bills. Reimbursement for reasonable charges for tolls and parking will be made upon presentation of supporting receipts.

Other Reimbursement: Staff must follow all rules concerning purchasing and School credit card use. If Staff otherwise personally advances money on behalf of the School, it does so completely at its own risk of non-reimbursement, provided however, the Board is authorized to reimburse such advances only if it finds that the expenditure was made without adequate opportunity for prior approval, or was an emergency and advanced as a necessity, for the benefit of the School. All reimbursements must be supported by detailed receipts.

Staff cannot be reimbursed for any expense if the Staff member received a benefit through a rewards program for that expense. Rewards programs allow users to earn rewards based on how much money they spend. Examples of rewards programs include, but are not limited to, frequent flier miles, grocery store loyalty card programs, and hotel free night programs. This prohibition includes rewards programs tied to credit cards and loyalty customer cards.

See also Policy Nos. 395 Purchasing Policies; 395.1 Purchase of Supplies and Materials, Equipment.

Ohio Ethics Comm. Advisory Opinion No. 91-010

In addition to the applicable policies set forth elsewhere in this manual, the following policies shall apply when the School expends federal grant funds to purchase property or obtain services.

- A. Competition. To the extent required by law, the School shall use procurement methods that provide for full, free, and open competition and comply with the federal procurement regulations. If the School solicits bids or competitive proposals to secure property or services, the School shall award the contract to the party whose bid or proposal, after considering all appropriate facts, is most advantageous to the School.

The School shall exclude from competition for procurements any contractor that develops or drafts specifications, requirements, statements of work, or invitations for bids or requests for proposals.

Unless allowed by law, the School shall not use statutorily or administratively imposed State, local, or tribal geographical preferences in the evaluation of bids or proposals.

- B. Code of Conduct. No employee, officer, or agent of the School shall participate in selecting, awarding, or administering a contract supported by federal funds if a conflict of interest, real or apparent, would be involved. A conflict arises when the employee, officer, or agent, a member of his/her family, his/her partner, or the employer or prospective employer of any of the above-mentioned individuals has a financial or other interest or a tangible personal benefit from the company selected to be awarded the procurement contract.

No employee, officer, or agent of the School may solicit nor accept gratuities, favors, or anything of monetary value from contractors or parties to subcontracts. Any gratuities, favors, or anything of monetary value includes money and every other thing of value, meaning having more than a de minimis or nominal worth.

All employees, officers, or agents of the School must disclose in writing any potential conflicts of interest, whether real or apparent, to the School prior to participation in the selection, award, or administration of a contract supported by a federal award.

The School shall not conduct any procurement action involving a parent, affiliate, or subsidiary organization that is not a state, local government, or Indian tribe, if the School would be unable or appear to be unable to be impartial in that procurement action.

Any employee, officer, or agent of the School found to have violated this Code of Conduct or any other applicable ethics laws or regulations will be immediately excluded from further participation in the selection, award, or administration of the contract supported by a federal award and may be subject to disciplinary actions, up to and including termination. The School shall promptly report any violation of federal criminal law involving fraud, bribery, or gratuity violations potentially affecting a federal award to the awarding federal agency and specify any corrective action taken by the School.

Nothing in this policy shall be read to alter the obligations and restrictions on public officials pursuant to Ohio Revised Code Chapters 3314 and 102, and Section 2921.42-.44 as applicable to community schools.

Date Adopted: 9/16/19

C. Procurement Procedures. To the extent required by law:

1. The School shall review any proposed procurement to avoid purchasing unnecessary property or services. The School shall avoid purchasing duplicative items.
2. Before acquiring an item, the School shall compare the advantages of leasing and purchasing property, purchasing surplus property, or sharing services where permitted by law in order to determine the most economical approach. The School shall also consider consolidation or breaking out procurements to obtain more economical purchases.
3. Prior to accepting bids or proposals, the School shall make independent estimates of cost and price. The School shall conduct a cost or price analysis in connection with every procurement transaction, including contract modifications. This shall include making independent estimates before receiving bids or proposals.
4. The School shall ensure that its solicitations for goods and services contain clear and accurate descriptions and technical requirements of the goods and services sought, all factors to be used in evaluating bids or proposals, and provide any other information required under the applicable federal regulations. Such description shall not, in competitive procurements, contain features which unduly restrict competition. The School shall not require brand name products unless the brand name is specified as a means to define the performance or other salient requirements of procurement.
5. The School shall attempt to ensure that the parties with which it contracts are responsible and capable of fulfilling the terms and conditions of the contract. The School shall give consideration to the contractor's integrity, compliance with public policy, record of past performance, and financial and technical resources.
6. The School shall only use time and material type contracts after a determination that no other contract is suitable and, if a contract includes a ceiling price, the contract must specify that the contractor exceeds the ceiling at its own risk.
7. The School shall create and maintain records that document the procurement process that the School followed in each procurement transaction, including the rationale for utilizing the selected procurement method, the selection of contract type, the basis for awarding or rejecting the contract, the justification for lack of competition if competitive bids or proposals are not sought, and the basis for the award cost or price.
8. The School shall make its procurement records available for review upon request by the awarding federal agency or pass-through entity.
9. Before deciding to use grant funds to host or attend a meeting or conference, the School shall ensure that the meeting or conference is (a) consistent with the School's approved grant application, (b) necessary to achieve the goals and objectives of the grant, and (c) for purposes of disseminating technical information, and (d) that the School has used only the grant funds necessary to accomplish legitimate meeting and conference business.
10. Whenever practicable, the School shall utilize lower cost alternatives in lieu of attending meetings or conferences.

11. When issuing statements, press releases, requests for proposals, bid solicitations, and other documents relating to the use of federal grant funds for procurement purposes, the School shall state the percentage of the total cost funded by federal money, the dollar amount of federal funds available for the project or program, and the percentage and dollar amount of the total cost of the project or program financed by non-governmental sources.
- D. Contract Provisions. Procurement contracts shall, at minimum, include the terms and conditions that are required by the applicable federal procurement regulations, including all necessary terms as required by the Trafficking Victims Protection Act of 2000 (TVPA). To the extent required by law, the School shall require that the person awarded a contract satisfy the bonding requirements set forth in the applicable federal regulations and shall comply with the TVPA and its corresponding regulations.
- E. Contract Administration. The School shall delegate to one or more school employee the responsibility for administering all procurement contracts and ensuring that the party awarded the contract satisfies the terms, conditions, and specifications of the procurement contract or purchase order.
- F. Small/Minority/Women Businesses. The School shall take affirmative steps to contract with small businesses, minority-owned firms, and women's business enterprises when possible. The School shall also require a contractor, if it subcontracts, to take affirmative steps to contract with small businesses, minority-owned firms, and women's business enterprises when possible.
- G. Dispute Resolution. Any issues related to the procurement contract and administrative procedures, including source evaluation, protests, disputes, and claims, will be resolved according to the following dispute resolution procedures, and the School will disclose information regarding the dispute to the appropriate federal officials. Any grievant must file a written complaint requesting an opportunity to be heard by the Governing Board or the Board's designee. The Board or its designee will review any information presented and provide a written decision within a reasonable time. If the grievant is not satisfied with this decision, the matter shall be submitted to a qualified mediator for mediation. The parties will make every attempt to resolve such disputes through mediation and shall equally split all fees or costs of any third party mediator.

If the School suspects or determines that the contractor has likely violated local, state, or federal law, the School will refer the matter to the proper authority having jurisdiction over the matter.

- H. Time and Materials Contracts. The School may use a contract whose cost to the School is the sum of the Actual costs of materials, and direct labor hours charged at fixed hourly rates that reflect wages, general and administrative expenses, and profit, but only:
1. After a determination that no other contract is suitable; and
 2. If the contract includes a ceiling price that the contractor exceeds at its own risk.
- I. Debarred, Suspended, or Ineligible Contractor. The School shall not award contract to parties that have been debarred, suspended, or otherwise excluded from or are ineligible for participation in Federal assistance programs and activities pursuant to the federal System for Award Management available at www.sam.gov.

The school shall verify that the contracting party is not excluded or disqualified by checking the federal system for award management, collecting a certification from the contracting party, or adding a clause or condition to the covered transaction with the contracting party.

J. Federal Grant Administration

The School shall ensure that these procedures are followed with respect to all federal grant applications submitted by the School and all federal grants that are awarded to the School.

1. Monitoring Grant Applications. The School shall delegate to one or more persons the responsibility for monitoring all pending federal grant applications, and that person or persons shall provide the Board with a report on the status of all federal grant applications at each regularly scheduled Board meeting.
2. Monitoring Grant Expenditures. The School shall delegate to one or more persons the responsibility for monitoring federal grant expenditures, and that person or persons shall provide the Board with a report on the expenditures made from each federal grant at each regularly scheduled Board meeting.
3. Final Expenditure Reports. The School shall delegate to one or more persons the responsibility for reviewing all final expenditure reports for each federal grant that the School was awarded, reconciling the report(s) with the School's financial records, and ensuring that the final expenditure report for each federal grant is complete and accurate.
4. Maintenance of Procurement Records. The Treasurer or his or her designee shall be responsible for maintaining records sufficient to detail the history of all procurements. For example, records of the rationale for the method of procurement, selection of contract type, contractor selection or rejection, and the basis for the contract price.

2 C.F.R. 200; 2 C.F.R. 175.15.

See Appendix 148.8-A Methods of Procurement Using Federal Grant Funds. See also Policy 114 Ethics and Conflicts Policy, Policy 148.2 Fixed Asset Policy/Title I and Federal Grant Assets Policy, Policy 149 Use of Cellular Telephones and Other Wireless Technologies, and Policy 205 Program Assessment.

The Governing Authority believes that it is the primary duty of the Board to establish, adopt and/or review policy and that of the Principal to help establish and to administer such policy. The Management Company, if any, should recommend policies, and be given the latitude to determine the best method of implementing the policies of the Board.

The Principal, as the chief executive officer of the School, is the primary professional advisor to the Board. S/He is responsible for the development, supervision, and operation of each program and service. His/her methods should be made known to the Staff through the administrative guidelines or Policies of the School. The Board shall retain oversight of such policies.

The fiscal agent is the primary professional advisor to the Board on fiscal matters even if subcontracted for, or hired by or through an independent management company. The fiscal agent may or may not be an officer or Board member of the Corporation but shall have general supervision of all financial matters overseen by the Board.

Attachment 3.2

The Edge Academy does not have a management company.

ATTACHMENT 3.4

CLOSING PROCEDURES ASSURANCE DOCUMENT

By signing this document, I, Staci Nevels, hereby certify that I am the School Governing Authority President and/or authorized representative of The Edge Academy. If The Edge Academy should cease to exist for any reason, including but not limited to suspension, closure or termination as outlined in Ohio Revised Code, Chapter 3314, the School Governing Authority agrees to cooperate fully with the Sponsor and comply with all Community School Closing/Suspension Procedures put in place by the Ohio Department of Education or the sponsor at the time of the School's closing.

Furthermore, the School Governing Authority appoints Faith DeCesare, or the then current School leader, as Designee, to coordinate the closure of the School and to ensure all requirements of the Community School Closing/Suspension Procedures as prescribed by the Ohio Department of Education and the sponsor at the time of the School's closing are fully completed.

The School Governing Authority President, Treasurer and Designee hereby acknowledge they have reviewed the Ohio Department of Education Community School Closing/Suspension Procedures in effect at the time of executing this document and understand the duties to be undertaken should the School close. Failure to complete these duties as prescribed may result in criminal or civil penalties as permitted by law. Additionally, should Governing Authority, School leader, treasurer or designee fail to ensure that all closing requirements are fulfilled the Sponsor will manage the closure process and may require the Governing Authority to reimburse the Sponsor for the costs associated with closure.

Upon closure or suspension of the school, any property that was acquired by the operator or management company of the school using state funds that were paid to the operator or management company by the School Governing Authority as payment for services rendered shall be distributed in accordance with division (E) of section 3314.015 and section 3314.074 of the Revised Code.

The designated fiscal officer and/or School Governing Authority shall ensure all financial and enrollment records are delivered to the Sponsor in a timely manner as well as to other entities specified in rule or Ohio Revised Code.

Staci Nevels
School Governing Authority President

2/4/2020
Date

Faith DeCesare
Designee

2/3/2020
Date

Treasurer

A handwritten signature in black ink, appearing to be "A. Sub", written over a horizontal line.

Date

2/5/2020

3.7 – Racial and Ethnic Balance Assessment – Edge Academy

During the first week of October of every school year, a count is taken by utilizing data gathered from EMIS. This data is summarized and a report is produced which is presented to the board in its October meeting. Due to the racial and ethnic makeup of the city of Akron, the administration and school board desire to see a reflection of the Akron community in the population which it serves. Therefore, the data that is collected is compared with other Akron City Schools that serve grades K-5.

When the board of education analyzes the report, they determine what measures, if any, need to be taken in order to improve the racial/ethnic balance of the school. The board then conducts discussions and makes plans for making any necessary changes before the start of the following school year. In the past, this action has usually involved mass mailings, outdoor advertisements (signs, etc.), and word of mouth communication between parents and students in their neighborhoods.

Meeting the balance is usually not a major problem because the racial/ethnic balance seems to be fairly consistent over the years. The numbers almost always reflect the racial/ethnic numbers of the general population of students living in the city of Akron.

Commitment to Racial and Ethical Balance

Racial Balance Assessment: Out of 225 students

92% African American

2% Caucasian

6% Multi Racial

0% Hispanic

The Edge Academy is committed to serve a diverse community of students and families and will not discriminate in its enrollment or admissions procedures. Our admission policy promotes the inclusion of all students, regardless of race, ethnicity, gender, learning or physical disability. It is our goal that the board/school's population demographically reflects the community's population. We will market to the community surrounding the school to the fullest extent possible to the support goal.

During the first week of October of every school year, a count is taken by utilizing data gathered from EMIS. This data is summarized and a report is produced which is presented to the board in its October meeting. Due to the racial and ethnic makeup of the city of Akron, the administration and board desire to see a reflection of the Akron community in the population which it serves. Therefore, the data that is collected is compared with other Akron City Schools which serve grades K-5.

When the board of education analyzes the report, they will determine what measures, if any, need to be taken in order to improve the racial/ethnic balance of the school. The board then conducts discussions and makes plans for making any necessary changes before the start of the following school year.

The board/school will use a variety of methods to promote racial and ethnic balance that reflects the population of the surrounding area. Consideration of the following resources will provide important insight when creating the school's annual marketing plan:

- The demographics of the area
- Population counts in the target locations
- Keeping the school website current with photos of students working collaboratively on projects.

- Continuing to celebrate different ethnicities throughout the year inviting the community into the school.
- Community media outlets
- Community organizations

Through community outreach, the board/school will develop and nurture partnerships with area businesses and organizations to create a sustainable community resource. Following are some actions which the board/school will take in order to attempt to attain this goal:

- Promote enrollment informational meetings
- Visit local preschools
- Distribute flyers to locations where target populations gather
- Do a once a year mass mailing which will reach out to families in local zip codes
- Contact sports/recreation leagues
- Contact local organizations serving children of all ethnic groups
- Investigate other community advertising opportunities.
- Contact all students who have shown a previous interest in the school
- Get student and faculty members involved in local service organizations

The School is open to any individual entitled to attend school in Ohio pursuant to R.C. 3313.64 or 3313.65, except that admission may be limited to the geographic area and grade or age levels specified in the Community School Contract.

The School will not discriminate in the admission of students to the School on the basis of race, creed, color, disability, sex, intellectual ability, measures of achievement or aptitude, or athletic ability, provided, however, that the School may limit admission to students identified as "at risk" in the Community School Contract. Upon admission of a student with a disability, the School will comply with all federal and state laws regarding the education of students with disabilities.

If there are more applicants than there are spaces, a lottery will be conducted in the following manner:

- Each applicant will be assigned a number;
- The numbers will then be drawn at random by a disinterested third party;
- The first number drawn will be the first new applicant placed on a permanent waiting list and so on until all numbers are drawn;
- Applicants on a permanent waiting list prior to any lottery will retain their position on the waiting list;
- The school may separate the lottery and the waiting lists for each grade or age grouping;
- Students attending the previous year and students who reside in the district in which the school is located will have first preference for a position;
- Secondary preference may be given to siblings of existing students and students who are the children of full-time School Staff, provided the total number of students receiving this preference is less than five percent (5%) of the School's total enrollment.

R.C. 3314.06.

See Policy 206 General Notice of Non-Discrimination, Policy 221 Access to Equal Educational Opportunity, Policy 241.3 Compulsory and Early Kindergarten Admission, Policy 241.5 Enrollment and Residency Policy, and Policy 241.6 Tuition for Out-of-State Students.

NOTICE

Pursuant to the Ohio Revised Code Section 3314.041, the governing authority of each community school and any operator of such school shall distribute to parents of students of the school upon their enrollment in the school the following statement in writing:

The Edge Academy is a community school established under Chapter 3314 of the Revised Code. The school is a public school and students enrolled in and attending the school are required to take proficiency tests and other examinations prescribed by law. In addition, there may be other requirements for students at the school that are prescribed by law. Students who have been excused from the compulsory attendance law for the purpose of home education as defined by the Administrative Code shall no longer be excused for that purpose upon their enrollment in a community school. For more information about this matter, contact the school administrator or the Ohio Department of Education.

241.2 Records upon Enrollment

Newly enrolled student records:

1. Upon entry, a request for records will be made within twenty-four (24) hours from the public or nonpublic elementary or secondary school the pupil most recently attended.
 - a. "Entry" is defined as the beginning of learning opportunities by a student at the School.
2. If the records are not received, a second request and contact with the parent and former school should be made within the first fourteen (14) days by the Principal or his/her designee.
3. If the records are not received within fourteen (14) days of the date of request, or the pupil's previous school indicates that it has no record of the pupil's attendance, or if the pupil does not present any one of the following: (1) a certification of birth; (2) a passport or attested transcript of a passport filed with a registrar of passports at a point of entry of the United States showing the date and place of birth of the child; (3) an attested transcript of the certificate of birth; (4) an attested transcript of the certificate of baptism or other religious record showing the date and place of birth of the child; (5) an attested transcript of a hospital record showing the date and place of birth of the child; or (6) a birth affidavit, the Principal will contact the former school directly, then the Principal or his/her designee will notify the law enforcement agency having jurisdiction in the area where the pupil resides of this fact and of the possibility that the pupil may be a missing child.
4. The School shall not admit any student requesting admission to the School after discharge or release from the custody of the department of youth services until the School is in receipt of (1) an updated copy of the student's academic transcript; (2) a report outlining the student's behavior in school while in custody of the department; (3) the student's current IEP if applicable; and (4) a summary of the institutional record of the student's behavior.
5. The School shall not deny admission to a child who has been placed in a foster home or in a residential facility (e.g., a group home, child's crisis care facility, children's residential center, residential parenting facility with 24-hour care, county children's home or district's children's home) if the child does not present a birth certificate, or a comparable certificate from another state or country, or another document specifically listed above in (3) to attest to the child's date and place of birth upon registration for admission. Required documentation must be presented within ninety (90) days of the child's initial entry into the School. If the required records are not produced within ninety (90) days of enrollment the Principal or his/her designee will notify the law enforcement agency having jurisdiction in the area where the pupil resides of this fact and of the possibility that the pupil may be a missing child. A student under the care of a domestic violence shelter at the time of initial enrollment shall notify the School of that fact, and the School shall inform the school from which it requests the pupil's records of that fact.
6. In the event that an order or decree is issued allocating or modifying an allocation of parental rights and designating a residential parent, or that a grandparent power of attorney or caretaker authorization affidavit is executed, that residential parent or grandparent shall provide the School with a complete and accurate copy of the order and any other relevant documentation.

Requests for student records:

1. Upon receipt of a request for student records, the School will comply within two (2) business days.
7. Copies of the student's records will be made and kept on file.

R.C. 3313.672; O.A.C. 3301-10-01.

See also Policy 252 Missing and Absent Children.

241.3 Compulsory Kindergarten Admissions

- A. The School shall admit a child to kindergarten if the child is five years of age prior to _____ August 1 or X September 30 [check one] of the year of admittance.
- B. The School chooses not to admit any child who will not be five prior to the date selected above, and therefore the School has no Early Admissions or Academic Acceleration Policy.
- C. First and other grade eligibility shall be based on the admissions, promotion, and retention policies of the School.

241.4 Enrollees Suspended or Expelled Elsewhere

The school has the authority to recognize and honor the disciplinary suspensions and expulsions imposed by other public schools. A student who has been suspended or expelled from another school district in Ohio may be denied admittance at the School for a period equal to the period of the original suspension or expulsion. The student will be provided an opportunity for a hearing before admittance is denied.

If the student has been expelled or otherwise removed for disciplinary purposes from a public school in another state, the School may deny admittance for the shorter of (1) the period of such expulsion or removal or (2) the period of expulsion or removal which would have been applied had the student committed the same offense in Ohio. Prior to denial of admission, the student will be given an opportunity for a hearing.

R.C. 3313.66(J)(1)-(2)

241.5 Enrollment and Residency Policy

The School admits students residing in the home district of Akron and Statewide The School serves grades K-5 and/or ages 5-11.

A child shall be admitted to the School as a student, if the child's parent resides in the School's admission areas. Residency is not determined solely by where the parents own or rent a home or an apartment, but rather by where the primary residence is and where substantial family activities take place. Any one (1) of the following documents can be used to establish proof of residency for verification of a child's ability to be enrolled. These items must be current, be in the parent's name, and include a street address. A post office box address cannot be used to validate residency records:

- a. A deed, mortgage, lease, current home owner's or renter's insurance declaration page, or current real property tax bill; or
- b. A utility bill or receipt of utility installation issued within ninety days of enrollment; or
- c. A paycheck or paystub issued to the parent or student within ninety days of enrollment that includes the address of the parent's or student's primary residence; or
- d. The most current available bank statement issued to the parent or student that includes the address of the parent's or student's primary residence; or
- e. Documented affirmation of the parent's address from the district of residence where the parent currently resides; or
- f. A USPS return receipt from a certified letter sent to the parents by the district of residence; or
- g. Written confirmation of the parent's current address from the Ohio Department of Job and Family Services; or
- h. Written confirmation of the parent's current address from a local law enforcement agency; or
- i. Any other official document issued to the parent or student that includes the address of the parent's or student's primary residence and as approved by the Ohio Superintendent of Public Instruction.

If there is a change in the location of the parent or student's primary residence, the student's parent must notify the School immediately.

The School shall monthly review the residency records of students enrolled in the School and shall provide an annual verification to the Ohio Department of Education that students are entitled to attend the School. Notwithstanding anything contrary in this policy, after a student's initial submission of one of the approved proof of residency records for enrollment purposes, the School may utilize either: one (1) newly submitted proof of residency documents listed in (a) through (j), or one (1) signed parent statement identifying the student's primary home address in order to conduct the monthly and annual verification. The Principal or his or her designee will compare each submitted proof of residence with the School's EMIS records to ensure that EMIS reporting is accurate that students are permitted to enroll.

All custody or court orders pertaining to the family or student must be turned in when asked, or at admission. If the School and Parent disagree as to residency status, the Superintendent of

Public Instruction shall determine the public school in which the student may enroll. If the School and the Student's home district (district of residency) disagree about residency, this policy shall supersede any policy concerning the number of documents for initial residency verification adopted by the student's home district. If the district of residence challenges the student's residency, the Principal may request additional documentation from the Parent, which may be provided to the student's home district.

R.C. 3314.03(A); R.C. 3314.11; R.C. 3313.64(B)(1); R.C. 3313.64(K)

See also Appendix 241.5-A Residency Verification Procedures; Appendix 241.5-B Monthly Residency Verification Report; Policy 204.8 Migrant Students; Policy 241 Admissions and Lottery Standards; Policy 241.3 Compulsory and Early Kindergarten Admissions; Policy 252 Missing and Absent Children; Policy 294 Student Records and Release of Information; Policy 297 Homeless Children and Youth Policy; and Policy 298 Grandparent Caretaker Policy.

241.6 Tuition for Out-of-State Students

The Board may open admission to the School on a tuition basis to any individual age five (5) to twenty-two (22) who is not a resident of Ohio, to the fullest extent allowed under state and federal law, and it may set or revise such tuition amount by Board resolution.

R.C. 3314.06.

275 Discipline/Suspension/ Expulsion of Disabled Students

In matters relating to the disciplining of disabled students, the Board shall abide by Federal and State laws regarding suspension and expulsion. The Principal will follow the guidelines below and ensure they are properly used when disciplining any student with a disability.

Removals of Not More Than 10 Days- The 10-Day Rule

The School may unilaterally remove a student with a disability who violates a code of student conduct from the student's current placement for not more than 10 school days. This option may be used only if the disciplinary action is consistent with actions taken against nondisabled students. The School may place students removed under the 10-day rule in an appropriate interim alternative educational setting ("IAES") if applicable (see below), another setting, or suspend them. Removals under the 10-day rule are not considered a "change of placement" and the School is not obligated to provide services to students during those removals. The School can use the 10-day rule to remove a student for either a single removal of 10 consecutive school days; or a series of shorter-term removals over the course of the school year that are more than 10 consecutive school days during that school year, so long as those removals do not constitute a pattern of removals (and therefore, a change of placement). When a removal is not a change of placement, an IEP meeting is not required. However, if one or more IEP team members believe that modifications are needed to the Student's behavior plan, the team shall meet to modify the plan and its implementation to the extent the team determines necessary.

Removals of More than 10 Days - Change of Placement

A change of placement occurs if a removal is for more than 10 consecutive school days; or if a student is subjected to a series of removals which accumulate to over 10 school days, that constitute a pattern. If a change of placement occurs (after a MDR (see below)), then the School must notify the parents or guardians of that decision. This notice must inform the parents or guardians of all the procedural safeguards accorded under the law. These safeguards include a manifestation determination review, a right to receive services, and a continuation of services for a free appropriate public education. The School must provide services that:

- enable the student to continue to participate in the general education curriculum (although in another setting); and
- enable the student to progress toward meeting the goals set out in the student's IEP.

Manifestation Determination Review ("MDR")

The School will conduct a MDR to examine a student's behavior before imposing disciplinary consequences that would amount to a change of placement. The purpose of the MDR is to determine whether a student's disability caused, influenced or otherwise impacted the student's behavior in question. To make this determination, the student's IEP team is required to review certain information and determine whether the behavior causing the disciplinary infraction is or is not a manifestation of the student's disability.

The MDR is not required for disciplinary removals that do not constitute a change of placement, that is, less than 10 school days per incident or a series of removals accumulating to more than 10 school days in one school year that do not constitute a pattern.

No later than the date on which the decision to take a disciplinary action which may be a change of placement is made, the School must notify the parents or guardians of that decision and of all procedural safeguards, including the MDR. The School and the parents or guardians must determine which members of the IEP team are relevant to conduct the manifestation determination. The team will review all relevant information in the student's file to determine whether the conduct in question was caused by, or had a direct and substantial relationship to, the student's disability or was the direct result of the School's failure to implement the IEP. If the team determines that either condition is applicable for the student, it must determine that the conduct is a manifestation of the student's disability.

Manifestation - If the team determines that the behavior was a manifestation of the student's disability, the full IEP team must meet the following requirements:

- conduct a functional behavior assessment and implement a behavior intervention plan for the student, unless the School conducted a functional behavior assessment prior to the manifestation determination;
- if the IEP team already developed a behavior intervention plan, it must review and modify the plan as necessary to address the behavior; and
- return the student to the placement from which he or she was removed, 45-day rule exception applies.

No Manifestation - If the team determines that the behavior was NOT a manifestation of the disability, the School may discipline the student using the relevant disciplinary procedures applicable to students without disabilities in the same manner and for the same duration, continuing to provide services to students with disabilities.

If a student's behavior was not a manifestation of the disability, the School will still take steps to attend to the student's behavior. The student must receive, as appropriate, a functional behavior assessment, behavioral intervention services and modifications designed to address the behavior violation in order to attempt to prevent a reoccurrence.

Exceptions to the MDR Requirement – The Unilateral Change in Placement and 45-Day Rule

School personnel may remove a student to an IAES for up to 45 school days, without a prior MDR or IEP meeting, when a student:

- carries or possesses a weapon (a device, instrument, material or substance, animate or inanimate, that is used for, or is readily capable of causing death or serious bodily injury, except that the term does not include a pocket knife with a blade of less than 2 1/2 inches in length);
- knowingly possesses or uses illegal drugs (a controlled substance not legally possessed or used under the supervision of a licensed health care professional, or legally possessed or used under any other authority under the Controlled Substances Act (21 U.S.C. §812) or under any other provision of federal law), or sells or solicits the sale of a controlled substance (a drug or other substance identified under Schedule I, II, III, IV or V in the Controlled Substances Act); or
- has inflicted serious bodily injury on another person (a cut, abrasion, bruise, burn or disfigurement, physical pain, illness, impairment of the function of a bodily member, organ or mental faculty, or any other injury, no matter how temporary).

This authority can be exercised if a student commits any of the offenses described above at the School, on the School premises or at a School function.

The IEP team will meet subsequent to the unilateral placement in an IAES, and must determine what the permanent setting will be, take steps to modify the student's IEP, as appropriate, provide appropriate behavioral intervention services and modifications designed to address the behavior violation so that it does not recur, and continue to provide the student with educational services to enable him or her to participate in the general education curriculum and to progress toward IEP goals.

The School must still do a MDR, but it can occur after the removal to the 45-day setting. If the conduct is a manifestation of the student's disability, the School must still meet all of the requirements outlined above for the MDR, with the additional exception that the student stay in the alternative placement for 45 school days, regardless of the outcome of the manifestation.

Due Process Complaint

Parents or guardians who disagree with any decision regarding placement or the outcome of an MDR may appeal the decision through the filing of a due process complaint, and may request an expedited due process hearing.

The School may request a hearing to change a student's placement if the School believes that maintaining the student's current placement is substantially likely to result in injury to the student or others. Under those circumstances, the hearing officer may order a change in placement of a student with a disability to an IAES for a period of up to 45 school days if the hearing officer agrees with the School's assessment.

During any due process proceedings, the student's placement, through a disciplinary action, must not change unless the parents/guardians and the School agree otherwise, or upon admissions to the School and parent/guardian consent. The School may change the student's placement when taking disciplinary actions that constitute a change of placement against students with disabilities, or students who may be eligible for IDEA services.

In the case where a student has been placed in an IAES, the student will remain in the IAES chosen by the School, pending the hearing officer's decision or until the time period expires, whichever occurs first, unless the parent and school agree otherwise. An expedited hearing will be arranged during an IAES appeal and will occur within 20 days of the hearing request, and the hearing officer must make a determination within 10 school days after the hearing.

275.1 Disciplining a 504 Student

Section 504 Manifestation Determination Reviews

A Student on a 504 Plan is to be afforded due process relating to any proposed change in educational placement where the Student is subject either to expulsion or suspension for a period of more than ten consecutive school days or a series of suspensions that are each 10 or fewer school days in duration, but exceed 10 school days in the aggregate and create a pattern of exclusions. In all such cases, except in the case where such suspension or expulsion pertains to the use or possession of illegal drugs or alcohol as detailed below, the School shall follow the procedures outlined in Policy Discipline/Suspension/Expulsion of Disabled Students.

Disciplinary Procedures for Students Possessing or Using Alcohol or Illegal Drugs

The School may take disciplinary action pertaining to the use or possession of illegal drugs or alcohol against any Student on a 504 Plan who currently is engaging in the illegal use of drugs or in the use of alcohol to the same extent that such disciplinary action is taken against Students without disabilities, in accordance with Policy No. 273 Expulsion and Suspension Policies. In such a case, the disability due process procedures found in Policy Discipline/Suspension/Expulsion of Disabled Students are inapplicable.

Emergency Removal from Placement

Emergency removal of a 504 student from his/her current placement may take place through parental agreement to an interim placement or through injunctive relief from a court, when the current placement presents a substantial likelihood of resulting in injury to the student or others.

29 USC § 701 et seq. (Section 504 of the Rehabilitation Act of 1973)

See also Policy No. 228 Section 504 of the Rehabilitation Act of 1973.

State-Mandated Assessments. The School shall administer State-mandated assessments (e.g., diagnostic assessments and achievement tests) to Students at the times designated by the State Board of Education. The School may, for medical reasons or other good cause, excuse a Student from taking a State-mandated assessment on the date scheduled, but any such assessment shall be administered to such excused Student not later than nine (9) calendar days after the last regularly scheduled test administration date. The School shall annually report to the State Board of Education, not later than June 30, the number of Students who have not taken one or more of the State-mandated assessments.

The Superintendent or his/her designee shall administer State-mandated assessments and submit the assessments to the entity with which the Ohio Department of Education contracts for the scoring of the tests, in accordance with Ohio law.

Diagnostic Assessments are assessments aligned with the Ohio academic content standards and model curriculum designed to measure student comprehension of academic content and mastery of related skills for relevant subject areas. Diagnostic assessments shall be administered by the School at least once annually for grades levels kindergarten through second grade in reading, writing, and mathematics, and for grade three in reading and writing to the following students:

- Any Student who transfers to the School if his/her former school did not administer each applicable diagnostic assessment to the Student in the current school year (must be administered within thirty (30) days from the date of transfer).
- Previously home-schooled Students enrolling at the School will be given a diagnostic assessment in order to determine their appropriate grade level placement.
- Each kindergarten student will complete the readiness assessment. The School shall administer the readiness assessment not earlier than the first day of the school year and not later than November 1 of that year, except the School may administer selected response and performance task items included in diagnostic assessments up to two weeks prior to the first day of the school year. The language and reading skills portion of the assessment must be administered by September 30 of that year.
- As required pursuant to the Third Grade Reading Guarantee. See Policy 245 Promotion and Retention Policy.

Social Studies Assessments are to be administered in at least the fourth (4th) and sixth (6th) grades. Assessments used for such purposes shall be determined by the School, and may be formative or summative in nature. The School shall not report the results of social studies assessments to the Ohio Department of Education.

Academic Prevention/Intervention Services. The School shall provide intervention services commensurate with the student's performance in pertinent subject areas to students who score below the proficient level on a reading, writing, mathematics, or science proficiency or achievement test or who do not demonstrate academic performance at their grade level based on the results of a diagnostic assessment.

If the School has a three-year average graduation rate of less than seventy-five percent (75%), then the School shall provide intervention services commensurate with the student's performance to any student whose results on the Ohio Graduation Test practice assessment indicate that the student is failing to make satisfactory progress toward being able to attain scores at the proficient level on the Ohio graduation tests. The School shall provide the intervention services prior to the end of the school year,

during the summer following ninth grade, in the next succeeding school year, or at any appropriate combination of those times.

Testing Time Limitations. Starting in the 2017-2018 school year, the School shall ensure that no student is required to spend more than two percent (2%) of the school year, cumulatively, taking State-mandated or other School-required assessments or spend more than one percent (1%) of the school year, cumulatively, taking practice or diagnostic assessments. The School may exceed these limitations by resolution of the Board, provided that the Board first conducts at least one public hearing on the proposed resolution.

These time limitations do not apply to:

- Assessments for students with disabilities;
- Related diagnostics for students who did not obtain a passing score on the third grade English language arts achievement assessment;
- Substitute advanced placement or international baccalaureate examinations; or
- Additional assessments administered to identify a student as gifted.

Recordkeeping. The School shall keep records for each student that include the following:

- A unique state student identification code or student data verification code in accordance with R.C. 3301.0714(D)(2);
- A list or designation of which assessments are required and which assessments are not required;
- A list or designation of which assessments, required or not required, are taken and which assessments are not taken during each assessment administration period;
- A score for each assessment taken, whether required or not required;
- Whether or not each student attained the requisite performance standard designated for each required assessment;
- What, if any, assessments must still be taken;
- Whether or not intervention must be provided; and
- For each test required for graduation, the date passed shall be recorded on the student's transcript. No information regarding a test not passed shall be on the student's transcript.

After the administration of any diagnostic assessment and upon a Parent's request, the School shall provide a Student's completed diagnostic assessment, the results of such assessment, and any other accompanying documents used during the administration of the assessment to the Student's Parent.

Retention. No results from required statewide assessments shall be used as the sole basis for determining whether or not to promote a student from grade to grade, except as specified in the Third Grade Reading Guarantee. However, the School may choose not to promote to the next grade level any student who does not take a State-Mandated Assessment if the student is not exempt from the requirement to take assessments.

Summer Remediation Services. Instruction will be developed and offered by the School during the summer to any student who failed to score at the proficient level on a third grade reading achievement test or a diagnostic assessment.

Superintendent Duties. The Superintendent or his/her designee shall develop an assessment system that includes:

- The administration of state-mandated assessments;
- Regular assessments of student performance;
- Multiple and appropriate assessments that will be used to measure student progress;
- Assessment practices that conform to current professional standards for validity and reliability; and
- Sharing information with parents, students, and the community regarding assessment purposes and results.

The Superintendent or his/her designee shall also develop:

- Procedures for using diagnostic assessments to measure student progress in accordance with academic standards;
- A plan for the design of classroom-based intervention services to meet the instructional needs of individual students as determined by the results of the diagnostic assessments;
- Procedures for the regular collection of student performance data; and
- Procedures for using student performance data to evaluate the effectiveness of intervention services and, if necessary, to modify those services.

Students with Disabilities. All identified students with disabilities in the School shall be considered for participation in State-mandated testing. The extent of the student's participation shall be determined by the IEP/504 team. The IEP/504 plan developed for the student must specify the manner in which the student will participate in the state achievement assessments. All students shall participate in diagnostic assessments except those with significant cognitive disabilities or other disabilities as authorized by the Ohio Department of Education on a case-by-case basis.

This policy shall be reviewed and updated annually.

R.C. 3301.0710-0711, 3301.0715, 3301.0729, 3313.608, 3313.6012, OAC 3301-13 et seq. and 3301-35 et seq.

See Appendix 242-A Assessment and Academic Prevention/Intervention Services Procedures. See also Policy 242.2 Alternate Assessments for Students with Disabilities; Policy 245 Promotion and Retention Policy; and Appendix 243-A Individual Student Assessment Recordkeeping Chart.

Date Adopted: 11/20/17
reviewed 5/13/19

School Name: Edge / AKROS

242.1 Security Provisions for Statewide Assessment Tests

A. Administrative Organization. The Principal or his/her designee will serve as the School coordinator for the Statewide assessments and is responsible for distributing, collecting, and securing (in a locked cabinet or closet) all testing materials while they are in the School and appointing specific staff members to serve as test examiners.

Examiners are responsible for distributing, administering, proctoring, collecting, and securing all test materials while they are in their possession.

The Principal or his/her designee and other staff members specifically designated to administer the tests are the only persons authorized to have access to the test materials or to be present in the testing room(s).

B. Security and Ethical Use of Test Materials. Achievement tests and all material developed for use for testing in any form (except practice tests) are "secure materials." All testing examiners and classroom teachers giving the test must follow these provisions, as well as the provisions of established by the Ohio Department of Education. It is unethical and illegal to: (1) alter a Student's responses or assist a Student in cheating in any way; (2) use, or help others to use, any secure materials to prepare Students for the test or to assist Students who have failed the tests; (3) reproduce any secure materials; (4) release secure materials to Students, parents, or any other individual or group.

C. Test Security Violations. All staff members are encouraged to voice any concern about any practice they consider unethical and/or inappropriate by reporting the alleged unethical activity to the Principal or his/her designee in writing. Any alleged test security or ethical violation will be investigated by the Principal or his/her designee. If it is determined that a violation occurred, any of several consequences may follow:

- A. All security or ethical breaches must be reported to the Ohio Department of Education within ten (10) days of any violation.
- B. One or more answer sheets may not be scored.
- C. The Board, after appropriate procedures are followed, may terminate or otherwise discipline an employee found guilty of a violation.
- D. The State Board of Education, following appropriate procedures, may seek the suspension of an educator's license certificate.
- E. A law enforcement agency, following an appropriate investigation, may prosecute under Ohio's criminal code.

Prior to commencing an Ohio Department of Education investigation and taking action as a result of an allegation of a test security violation, the State Board of Education will provide the individual with notice of the allegation and an opportunity to respond and present evidence.

D. Building Administration. All coordinators and examiners are responsible for ensuring that all test security provisions are followed while the test materials are at the School. All test coordinators and classroom teachers giving the test must read the Directions for Administration and Rules for Testing prior to the testing dates. All test coordinators must keep these booklets on file. The tests will be serially numbered and wrapped in sealed packages when they arrive at the test sites. The testing coordinator is to open the sealed packages at the appropriate time, check and verify in writing the accuracy and receipt of all test materials, and prepare the test booklets. Since testing coordinators are required to account for and

Date Adopted: 9/16/19

return all materials, they must carefully track the materials before, during, and after test administration. This responsibility includes the timely packing and shipping of all used materials and transporting any unused materials to the Principal or his/her designee for shipment. Careful written recordkeeping and thorough rechecking are essential throughout the testing process.

E. Final Accounting of Missing Materials. Whenever possible, testing materials are computer scanned before they are shipped to the School and scanned again after they are returned to the testing company. Should any testing materials be unaccounted for after testing materials are returned to the testing company, the Principal or his/her designee, along with the appropriate examiner(s), will conduct a thorough investigation. If, after the investigation of all written records, the materials are still unaccounted for, the Principal or his/her designee will report his/her findings the Ohio Department of Education. If further investigation should occur, the individual(s) involved will be provided with an opportunity to respond to the charges and present a defense.

F. Communication of this Policy with Students and Staff. By the first of October each school year, the Principal will ensure that this policy is handed out to and discussed with students participating in the assessments, as well as staff members who administer the assessments, are authorized to be in the assessment room, and/or who have access to the assessment materials. Students and staff shall be reminded orally prior to each test administration period.

G. Participation of Students with Disabilities. Students with disabilities participate in the Statewide assessments, with appropriate accommodations, as necessary. Decisions about how a Student with a disability will participate in any statewide assessment program will be made by the IEP team. The IEP developed for a disabled student must specify the manner in which the student will participate in the state achievement assessments. See Policy 242.2 Alternate Assessments for Students with Disabilities.

H. Participation of English Learners. Students that are English learners participate in the Statewide assessments according to the applicable rules and laws. They may receive approved accommodations following consultation with their instructor.

OAC 3301-7-01; OAC 3301-13-05

See Appendix 242.1-A Standards for the Ethical Use of Tests.

245 Promotion and Retention Policy

The Board recognizes that the personal, social, physical, and educational growth of children will vary, and that they should be placed in the educational setting most appropriate for their needs at the various stages of their growth. Each student will be moved forward in a continuous pattern of achievement and growth that is in harmony with his/her own development. Parent(s) and students are made aware of the instructional objectives, performance standards, and promotion criteria. Periodically during the year teachers shall provide written progress and grade reports. Teachers will also provide evaluation reports to parent(s) and students during teacher-parent conferences. The grading system used to measure student progress toward achieving the predetermined instructional objectives and performance standards is applied consistently throughout the School. All promotion and retention decisions are subject to the third grade reading guarantee requirements.

Promotion

A student will be promoted from one grade to the next provided the student meets the applicable promotion criteria. The decision to promote a student shall rest solely with the Principal, with appropriate input from the student's teacher(s), the professional staff, and parent(s).

Retention

A student is required to be retained if he/she is truant for ten percent (10%) or more of the required school days and has failed at least two (2) courses of study, unless the Principal and the teachers of the failed subjects determine that the student is academically prepared to be promoted.

Additionally, a student shall not be promoted or allowed to pass to a higher grade or course level if the student fails to meet established standards for a particular grade or course level.

Retention decisions will be made only after the Principal or applicable teachers have notified and conferred with parent(s) as to the student's progress or lack thereof. These notifications and conferences will take place as soon as teachers and the Principal identify that a student's promotion could be in jeopardy.

Factors

Teachers and the Principal will consider at least the following factors in arriving at decisions on promotion or retention. Factors are applicable in all grade levels.

- The student's level of academic aptitude and achievement;
- The student's level of social and emotional development and the student's ability to effectively interact with other students in his/her current grade level;
- The student's attendance patterns (absences, tardies, early checkout, excused, or unexcused) and its effect on the student's progress; and
- Any other factors thought to be appropriate by the Principal, teacher(s), and professional staff.

The School will not utilize a Student's failure to attain a specified score on any statewide achievement assessment as a factor in any decision to deny a Student's promotion to a higher grade level, except that the School may use a Student's failure to attain a score in at least the basic range as a factor in deciding to deny a Student's promotion to the next level on the following assessments:

- 3rd grade math and English language arts achievement assessments;
- 4th grade English language arts and math achievement assessments, and the formative or summative social studies assessment prescribed by the School;
- 5th grade English language arts, math, and science achievement assessments;
- 6th grade English language arts and math achievement assessments, and the formative or summative social studies assessment prescribed by the School;
- 7th grade English language arts and math achievement assessments; or
- 8th grade English language arts, math, and science achievement assessments.

The School may choose not to promote to the next grade level a Student who does not take a required statewide achievement assessment or make-up assessment, and who is not exempt from the requirement to take such assessment.

Disabled Students

Promotion and retention of previously identified disabled students shall be subject to the factors and policy above, but shall also consider the contents of the student's individualized educational plan (IEP).

Third Grade Guarantee

The School will not promote any student to the fourth grade who does not achieve at least the level equivalent to the level designated by the Ohio Board of Education unless:

- The student is an English learner who has been enrolled in U.S. schools for less than three full school years and has had less than three years' instruction in an English as a second language program;
- The student is a student with a disability entitled to special education and related services and the student's IEP exempts the student from retention;
- The student demonstrated an acceptable level of performance on an alternative standardized reading assessment as determined by the Ohio Department of Education;
- The student received intensive remediation for reading for two school years but still demonstrates a deficiency in reading and was previously retained in any grades K through 3; or
- All of the following apply:
 - The student is a student with a disability;
 - The student has taken the third grade English language arts achievement assessment;
 - The student's IEP or 504 plan shows that the student has received intensive remediation in reading for two school years but still demonstrates a deficiency in reading; and
 - The student previously was retained in grades K-3.

If a student is promoted despite not attaining the Ohio Board of Education specified level (which may change yearly), the student will continue to receive intensive reading instruction in the fourth grade, including an altered instructional day, specialized diagnostic information, and specific research-based reading strategies that have been successful in improving reading among low performing readers.

If the student is retained, the School shall:

- Provide intensive remediation until the student is able to read at grade-level, including intensive interventions in reading and a minimum of ninety (90) minutes of daily reading, that address the deficient areas; and
- Provide each student with a high-performing teacher, as determined by the teacher's student performance data when available, and performance reviews.

If a student who has been retained demonstrates that he or she is reading at or above grade level, the student may be promoted mid-year to the fourth grade at the Principal's discretion.

Intervention

Annually, the School will assess the reading skills of each student enrolled in grades 1 to 3 by September 30, and in kindergarten by November 1, and will identify students who are reading below grade level, except those students with cognitive disabilities or other disabilities as authorized by the Ohio Department of Education on a case-by-case basis. The students' classroom teachers shall be involved in the assessment and identification of students reading below grade level, however such assessment may be administered electronically using live, two-way video and audio connections if the teacher administering the assessment is in a separate location from the student.

For students reading below grade level, the School will:

- Provide written notification to the student's parent(s) that includes the following:
 - A statement that the student has been identified as having a substantial deficiency in reading;
 - A description of the current services that are provided to the student;
 - A description of the proposed supplemental instructional services and supports that will be provided to the student that are designed to remediate the identified areas of reading deficiency;
 - A statement that if the student receives a score within a certain range on the assessment to measure English and language arts skills, the student will be retained unless the student is exempt; and
 - A statement that the assessment is not the sole determinant of promotion and that additional evaluations and assessments are available to assist the School and parent(s) in knowing whether the student is reading at or above grade level and is ready for promotion.
- Provide intensive reading instruction services and regular diagnostic assessments to the student immediately following identification of a reading deficiency, including research-based reading strategies that have been shown to be successful in improving reading among low-performing readers and targeted at the student's identified deficiencies.
- Develop a reading improvement and monitoring plan within sixty (60) days after receiving the student's results on the diagnostic assessment. The plan must include:
 - Identification of the student's specific reading deficiencies;
 - A description of the additional instructional services and support that will be provided to the student to remediate the identified reading deficiencies;
 - Opportunities for the student's parent(s) to be involved in the instructional services and

support;

- A process for monitoring the extent to which the student receives the instructional services and support;
- A reading curriculum during regular school hours that does all of the following: assists students to read at grade level, provides scientifically based and reliable assessment, and provides initial and ongoing analysis of each student's reading process; and
- A statement that if the student fails to attain a level designated by the Ohio Board of Education on the assessment to measure skill in English language arts expected by the end of the third grade, the student may be retained in the third grade.

Teacher Qualifications

Each student with a reading improvement and monitoring plan shall be assigned a teacher who has at least one year of teaching experience and:

- Holds a reading endorsement on the teacher's license and has attained a passing score on the corresponding assessment for that endorsement, as applicable; or
- Completed a master's degree program with a major in reading; or
- Was rated "most effective" for reading instruction consecutively for the most recent two years based on assessments of student growth measures developed by a vendor and that is on the list of student assessments approved by the State Board of Education; or
- Was rated "above expected value added" in reading instruction, as determined by criteria established by the Ohio Department of Education, for the most recent consecutive two years; or
- Earned a passing score on a rigorous test of principles of scientifically research-based reading instruction approved by the State Board of Education; or
- Holds an educator license for teaching grades pre-kindergarten through three or four through nine issued on or after July 1, 2017.

The student may be assigned a teacher with less than one year of teaching experience provided that teacher meets one of the above criteria and is assigned a teacher mentor who also meets the qualifications above.

A student with a reading improvement and monitoring plan who enters the third grade after July 1, 2013 but prior to July 1, 2016, a student who is an English language learner and has been in the United States for three years or less, or a student who has an IEP may be assigned a teacher who holds an alternative credential approved by the Ohio Department of Education or who has successfully completed training based on principles of scientifically research-based reading instruction approved by the Ohio Department of Education. Beginning July 1, 2014, the alternative credentials and training must be aligned with the reading competencies adopted by the State Board of Education.

Nothing in the Third Grade Guarantee prevents a student with a reading improvement and monitoring plan from receiving reading intervention and remediation services from an individual employed as a speech-language pathologist who holds a license issued by the board of speech-language pathology and audiology and a professional pupil services license as a school speech-language pathologist issued by the State Board of Education.

A teacher other than the student's assigned teacher may provide any services required under the Third Grade Guarantee, provided that the teacher meets the qualification requirements and that the assigned teacher and Principal agree to the assignment. Any such assignment of services must be documented in the student's reading improvement and monitoring plan.

Reporting Requirement

The School shall annually report to the Department of Education its implementation and compliance with the Third Grade Guarantee.

When a student enrolls in the School, the School will provide the parent(s) with a copy of the most recent School report card.

R.C. 3313.608; 3313.609; 3301.0710; 3301.0711; 3313.6411(B); 20 USC 1400 et seq.

It is the School's expectation that all students will graduate from high school with a high school diploma; however, the School recognizes that some students from time-to-time may face hardships that put them at-risk of not graduating. For this reason, the School will begin complying with this policy on July 1, 2020.

Graduation Plan

The School shall develop a graduation plan for each student enrolled in grades nine through twelve, unless the student is which shall address the student's academic pathway to meet graduation requirements. The graduation plan shall be developed jointly by the student and a representative of the School. Parents shall also be invited to participate in the development of the graduation plan. The plan shall be updated annually until the student graduates with a high school diploma or is no longer enrolled in the School.

A graduation plan is intended to supplement an existing student success plan. In lieu of a graduation plan, a student with a qualifying disability may use an individualized education program ("IEP") that contains academic goals substantively similar to those in a graduation plan.

Criteria and Identification of At-Risk Students

A student may be considered "at-risk" of not graduating if the student is in grades nine to twelve and has either (a) demonstrated a lack of adequate progress in meeting the requirements for graduation specified in the student's graduation plan, (b) is at least one grade level behind his or her cohort age group, or (c) the student experiences a crisis that significantly interferes with his or her academic progress.

During the course of the year, teachers have the most frequent and meaningful contacts with students, and are therefore the most likely to first notice that a student is experiencing a crisis that is significantly interfering with the student's academic progress. If a teacher becomes aware of a student meeting the at-risk criteria, the teacher should notify the Principal or his or her designee of concerns. The Principal or his or her designee in turn will investigate and determine if the student is at-risk of not graduating.

At least once each academic year, the Principal or his or her designee will determine the names of any students who failed to demonstrate adequate progress in meeting graduation requirements or are one or more years behind their respective cohort age group.

Parental Notification Process

The Principal or his or her designee shall provide written notice to the parent of any student identified as at-risk of not qualifying for a high school diploma. The written notice shall include a description of the School's curriculum and graduation requirements, or, if applicable, the requirements for graduation pursuant to a student's IEP. The notice shall also detail the additional instructional and support services available to the student to earn a high school diploma. Additional instructional or support services will be made available to students at-risk of not graduating. Instructional or support services may include mentoring programs, tutoring, earning credit through demonstration of subject area competency and adjusted curriculum options, career-technical programs, mental or physical health services (to the extent required by an IEP or Section 504 Plan), family engagement and support services, or other services deemed appropriate by the Principal or his or her designee.

R.C. 3313.617.

Appendix 248-A Graduation Plan Invitation Letter to Parent, Appendix 248-B Parental Notification That Student is At-Risk of Not Graduating, Appendix 248-C Graduation Plan. Policy 204.14 Career Advising and Student Success Plans.

Date Adopted: 9/16/19

242.2 Alternate Assessments for Students With Disabilities

All students with disabilities are required to participate in state assessments as determined annually by the student's IEP team. The IEP developed for a disabled student must specify the manner in which the student will participate in the state achievement assessments.

A. Regular Assessments With Accommodations

For any student with disabilities who takes an assessment that is administered to nondisabled students, the school shall include that information in the student's IEP or document that information in writing for a Section 504 student, and provide the student with any appropriate accommodations pursuant to this policy. Any accommodations shall meet all of the following criteria specified below:

1. The accommodation is specified in the student's IEP or 504 Plan and is provided for classroom and schoolwide assessments.
2. The accommodation does not change the content or structure of an assessment.
3. The accommodation does not change what type of knowledge or skill that an assessment is intended to measure.
4. The accommodation does not change or enhance the student's response as to what type of knowledge or skill is intended to be assessed, but it facilitates how the response is provided or assessed.

B. Alternative Assessments

A student's IEP team may excuse a student with disabilities from taking any particular assessment that is administered to nondisabled students during any school year. An excused student with disabilities shall participate instead in an alternate assessment approved by the Ohio Department of Education. A valid excuse must meet all of the following criteria:

1. The student is completing a curriculum that is modified substantially in form and/or substance by the IEP from the general education curriculum, or the student is completing the regular curriculum, but the student has a disability that presents unique and significant challenges such that the student's IEP provides for accommodations in classroom and schoolwide tests that do not meet the criteria of this policy.
2. The student has a significant cognitive disability.
3. The student requires instruction focused on the application of state standards through essential life skills.
4. The student requires instruction at multiple levels below age or grade level.
5. The student who is unlikely to provide valid and reliable measures of proficiency in content areas in a standardized assessment with accommodations that meet the criteria included in this policy.

Each excuse from participating in assessments administered to nondisabled students shall be documented in a student's IEP or 504 Plan, stating why the particular alternate assessment selected is appropriate for the student, as well as the explanations and reasons for the excuse and a description of benchmarks or short term objectives. Accommodations may be used in accordance with the criteria provided in Part A of this Policy. The school shall conduct the

alternate assessment and report results according to the guidelines established by the Ohio Department of Education.

Any student excused from taking a regular assessment who nevertheless wishes to take a regular assessment, may do so, and if that student meets at least the proficient level of performance, the student's transcript will show that the performance standard was met. Accommodations may be used, so long as each accommodation provided meets the criteria provided in Part A of this Policy.

Statewide assessment pass rates used to determine school and building performance include the results of those who take assessments without any accommodation; those who take assessments with accommodations that meet the criteria of this policy; and those who are excused under this policy and take alternative assessments.

Any student with disabilities who otherwise has completed an IEP program but has not received a diploma due to not having passed a required assessment may take any assessment required for graduation at any time it is administered in any school.

OAC 3301-13-03.

See **Appendix 242.2-A** Guidelines for Participation in Ohio's Alternate Assessment for Students with Disabilities.

The School will utilize a range of assessment methods to judge student performance. The School recognizes its responsibility for providing a system of grading student achievement that can help the student, teachers and parents judge properly how well the student is achieving the goals of the School's Program. [See also policy nos. 203 to 203.5 on Parent Involvement.]

The Board believes that the School's grading system should be a reliable system and one that ensures each student's grades signify accurately his/her degree of accomplishment of those expected learning goals which are to be stated for each program at every grade level, kindergarten through 12.

The Principal or his/her designee shall develop procedures for grading which

1. Have clear, consistent criteria and standards particularly when grades are based on subjective assessment;
2. Help each student understand in each course or program what behavior and/or achievement is needed to earn each grade as well as what will produce a failing grade; and
3. Provide frequent opportunities for each student to obtain information as to his/her progress toward the learning goals of his/her courses or programs.

The teacher responsible for a student's instruction in a particular course or program shall determine the student's grade. That grade may not be changed without the permission of the Principal or his/her designee.

LEASE AGREEMENT

THIS LEASE AGREEMENT (“Lease”) is made and entered into this ____1st____ day of July, 2022, by and between **Edge Learning Inc.**, an Ohio not for profit corporation, whose principal place of business is 92 N. Union St. Akron, Ohio 44304 (hereinafter referred to as ‘Tenant’), and **CHARTER DEVELOPMENT FOUNDATION, INC.**, an Ohio nonprofit corporation, whose principal place of business is 265 Park St., Akron, Ohio 44304 (hereinafter referred to as “Landlord”).

ARTICLE I **GRANT OF LEASE**

1.01 Landlord, in consideration of the rents to be paid and the covenants and agreements to be performed and observed by the Tenant, does hereby lease to the Tenant and the Tenant does hereby lease and take from the Landlord that portion of the building located at 92 N. Union, Akron, Ohio, 44304 consisting of approximately 16,000 square feet and being shown by the cross-hatched section on Exhibit A attached hereto and by reference made a part hereof (the “Premises”). Landlord additionally grants to Tenant during the term of this Lease, the right to use in common with Landlord and other occupants of the building (a) all easements and rights appurtenant to the property, (b) all portions of the building (if any) designed for the common use of all occupants of the building, and (c) all common areas and designated parking areas as shown on Exhibit A. Tenant’s use of the Premises shall be subject to such reasonable rules and regulations as Landlord may adopt from time to time.

ARTICLE II **LEASE TERM AND CONDITION OF PREMISES**

2.01 ***Total Term of Lease.*** The term of this Lease shall begin on the Commencement Date, as defined in Section 2.02 of this Article II. and shall terminate on June 30, 2025.

2.02 ***Commencement Date.*** The “Commencement Date” shall mean July 1, 2022, or if later, the date on which the Tenant shall commence to conduct business on the Premises, so long as such date is not in excess of ninety (90) days subsequent to execution hereof.

2.03 ***Condition of Premises.*** Tenant acknowledges that it has inspected the Premises, found the same to be satisfactory and accepts the same in its “AS IS” present condition.

ARTICLE III **RENT**

3.01 The Tenant agrees to pay the Landlord and the Landlord agrees to accept, during the term hereof, at the Landlord’s principal place of business or at such place as the Landlord shall from time to time direct by written notice to the Tenant, rent at the following rates and times:

(a) ***Annual Rent.*** Annual rent for the term of the Lease shall be One Hundred Twenty-Five Thousand Nine Hundred Fifty Two Dollars (\$125,952).

(b) ***Payment of Annual Rent.*** The annual rent shall be payable in advance in equal monthly installments of one-twelfth (1/12th) of the total yearly rent, which shall be equal to Ten Thousand Four Hundred Ninety-Six Dollars, (\$10,496) per month, beginning on the

Commencement Date and continuing on the first day of each and every calendar month during the term hereof. In the event the Lease commences on a day other than the first day of a month, rent shall be prorated for each fractional part of a month for which the Tenant actually occupies and utilizes the Premises. If any installment of rent is not fully paid within five (5) days after the due date, a late charge of five percent (5%) of the amount due shall be due Landlord as additional rent to compensate Landlord for loss and expense occasioned by the delinquency in payment.

Reference to Annual Rent hereunder shall not be implied or construed to the effect that this Lease or the obligation to pay rent hereunder is from year to year, or for any term shorter than the existing Lease term.

ARTICLE IV **SECURITY DEPOSIT**

4.01 The Tenant shall not be required to make any deposit or provide any other collateral as security for the full and faithful performance by the Tenant of all the terms of this lease required to be performed by the Tenant.

ARTICLE V **TAXES**

5.01 ***Personal Property Taxes.*** The Landlord shall be liable for all taxes levied against any leasehold interest of the Tenant, however the Tenant shall be liable for and shall pay when due, taxes upon personal property and trade fixtures owned and placed in the Premise by the Tenant.

5.02 ***Real Estate Taxes.*** During the continuance of this lease Tenant shall pay, all real estate taxes and assessments applicable to the Premises, together with any interest and penalties lawfully imposed thereon, which may be levied upon the Premises during the term of this Lease.

5.03 ***Contest of Taxes.*** The Tenant, at its own cost and expense, may, if it shall in good faith so desire, contest by appropriate proceedings the amount of any personal property tax. Landlord may, if it shall so desire, endeavor at any time or times, by appropriate proceedings, to obtain a reduction in the assessed valuation of the Premises for tax purposes. In any such event, the Landlord and Tenant agree that, at the request of the Landlord, the Tenant will sign and deliver such papers and instruments as may be necessary to enable the Landlord to prosecute such proceedings.

5.04 ***Payment of Ordinary Assessments.*** The Tenant shall pay all assessments, ordinary and extraordinary, attributable to or against the Premises.

5.05 ***Other Taxes.*** The Landlord and Tenant agree that any liability for income, franchise, or excise taxes that may be imposed, (including but not limited to Federal Income Tax, the Tax on Prohibited Transactions, or the Tax on Unrelated Taxable Business Income), shall be solely the liability and responsibility of the party upon whom such liability is imposed and accordingly neither party shall be liable for such taxes assessed against the other party.

ARTICLE VI **UTILITIES**

6.01 ***Utilities.*** Tenant shall pay for Tenant's reasonable use of water, sanitation, sewer, electricity,

light, heat, gas, power, fuel, janitorial, and other services on the Premises, whether or not the cost thereof be a charge or imposition against the Premises.

ARTICLE VII
OBLIGATIONS FOR REPAIRS AND MAINTENANCE

7.01 ***TENANT's Repairs and Maintenance – Structural, Exterior and Infrastructure.*** The Tenant shall be required to keep in reasonably good order, condition and repair (i) the roof and all structural elements and portions of the Premises and building, (ii) all exterior elements and portions of the building, (iii) the parking areas, drives and other exterior improvements located on the property, and (iv) any common pipes, conduits, equipment and systems that serve Tenant's space and also serve other parts of the building; subject, however, to ordinary wear and tear.

7.02 ***TENANT'S Repairs and Maintenance.*** Unless otherwise agreed to in writing by Landlord and Tenant, the Tenant shall perform all repairs and maintenance and make all replacements as are necessary to keep in good order, condition and repair, all portions of the interior of the Premises, ordinary wear and tear excepted. Tenant further agrees that it will not cause or permit any waste or damage to the Premises, nor allow the accumulation of boxes, barrels, packages, wastepaper or other trash, it being Tenant's responsibility to provide for its own trash and rubbish removal from the Premises to the designated dumpster. In addition, Tenant at its expense shall repair, replace or restore all damage to the Premises or the building caused by the negligent acts or omissions of Tenant or its agents, employees or invitees. Tenant shall be solely responsible for the maintenance and repair of any special facilities needed for Tenant's operations, including: lawn care and snow removal; and janitorial services and supplies.

7.03 Requirements of the Law. The Tenant agrees that if any federal, state or municipal government or any department or division thereof shall condemn the Premises or any part thereof as not in conformity with the laws and regulations relating to the construction thereof as of the Commencement Date with respect to conditions latent or otherwise which existed on the Commencement Date, or, with respect to items which are the Landlord's duty to repair pursuant to Section 7.01 of this Article VII; and such federal, state or municipal government or any other department or division thereof, has ordered or required, or shall hereafter order or require, any alterations or repairs thereof or installations and repairs as may be necessary to comply with such laws, orders or requirements; and if by reason of such laws, orders or the work done by the Landlord in connection therewith, the Tenant is deprived of the use of the Premises, the rent shall be abated or adjusted, as the case may be, in proportion to that time during which, and to that portion of the Premises of which, the Tenant shall be deprived as a result thereof, and the Landlord shall be obligated to make such repairs, alterations or modifications at Landlord's expense; provided the violation with the laws and regulations is not caused by Tenant's use or occupancy of the Premises for its intended purposes.

7.04 ***TENANT'S Alterations.*** The Tenant shall have the right, at its sole expense, from time to time, to redecorate the Premises and to make such non-structural alterations and changes in such parts thereof as the Tenant shall deem expedient or necessary for its purposes; provided, however, that such alterations and changes shall not impair the structural soundness of the building, diminish the value of the Premises and Tenant shall first obtain Landlord's written consent to make the alterations, additions or improvements, which consent shall not be unreasonably withheld. Notwithstanding the above, the Landlord may withhold its consent if any improvement is found by the Landlord, in its sole discretion, to be against the Landlord's rules and regulations. Upon termination of this Lease, any alterations, additions or improvements made by Tenant shall

become the property of Landlord, excluding trade fixtures which may be removed by Tenant.

7.05 *Permits and Expenses.* Each party agrees that it will procure all necessary permits for making any repairs, alterations, or other improvements for installations, when applicable. Each Party hereto shall give written notice to the other party of any repairs required of the other pursuant to the provisions of this Article and the party responsible for said repairs agrees promptly to commence such repairs and to prosecute the same to completion diligently, subject, however, to the delays occasioned by events beyond the control of such party.

Each party agrees to pay promptly when due the entire cost of any work done by it upon the Premises so that the Premises at all times shall be free of liens for labor and materials. Each party further agrees to hold harmless and indemnify the other party from and against any and all injury, loss, claims or damage to any person or property occasioned by or arising out of the doing of any such work by such party or its employees, agents or contractors. Each party further agrees that in doing such work that it will employ materials of good quality and comply with all governmental requirements, and perform such work in a good and workmanlike manner.

ARTICLE VIII TENANT'S COVENANTS

8.01 *TENANT'S Covenants.* Tenant covenants and agrees as follows:

- (a) To procure any licenses and permits required for any use made of the Premises by Tenant, and upon the expiration or termination of this Lease, to remove its goods and effects and those of all persons claiming under it, and to yield up peaceably to Landlord the Premises in good order, repair and condition in all respects; excepting only damage by fire and casualty covered by Tenant's insurance coverage, structural repairs and reasonable wear and tear;
- (b) To permit Landlord and its agents to examine the Premises at reasonable times and to show the Premises to prospective purchasers of the Building and to provide Landlord, if not already available, with a set of keys for the purpose of said examination, provided that Landlord shall not thereby unreasonably interfere with the conduct of Tenant's business;
- (c) To permit Landlord to enter the Premises to inspect such repairs, improvements, alterations or additions thereto as may be required under the provisions of this Lease. If, as a result of such repairs, improvements, alterations, or additions, Tenant is deprived of the use of the Premises, the rent shall be abated or adjusted, as the case may be, in proportion to that time during which, and to that portion of the Premises of which, Tenant shall be deprived as a result thereof.
- (d) To comply with all present and future laws and regulations applicable to its use and occupancy of the Premises, and to the extent required under Section 7.02, shall make any repairs, modifications, or additions to the Premises that may be required by those laws.

ARTICLE IX INDEMNITY AND INSURANCE

9.01 *Tenant's Public Liability.* Tenant shall maintain, with respect to the Premises, public liability

insurance with limits of not less than One Million Dollars (\$1,000,000.00) combined single limit for injury or death from one accident and Two Hundred Fifty Thousand Dollars (\$250,000.00) property damage insurance, insuring Landlord and Tenant against injury to, or damage to property on or about the Premises. In addition thereto Tenant shall secure umbrella coverage in the amount of at least One Million Dollars (\$1,000,000.00) for general liability which shall insure both Tenant and Landlord. A copy of the policy or a certificate of insurance shall be delivered to Landlord on or before the Commencement Date and no such policy shall be cancelable without ten (10) days prior written notice to Landlord. The Landlord shall be listed as an additional insured on the policies.

9.02 ***Landlord's Public Liability*** Landlord shall maintain at its sole cost and expense public liability insurance, property damage insurance with respect to the Premises in such amounts as it deems appropriate and necessary in the ordinary course of business; provided that such insurance shall not be less than the amount maintained by Tenant under Section 9.01 hereof.

9.03 ***Insurance Proceeds.*** In the event of any damage to or destruction of the Premises, which is recoverable under Tenant's policy of insurance, Tenant shall adjust the loss and settle all claims with the insurance companies issuing such policies. Any insurance proceeds in excess of such proceeds as shall be necessary for such repair, restoration, rebuilding, replacement or any combination thereof shall be the sole property of Tenant.

9.04 ***Co-Insurance/Contribution for Property Damage.*** Landlord and Tenant hereby release each other, to the extent of the insurance coverage required hereunder, or if greater, the amount of actual insurance coverage maintained by the respective parties hereto, from any and all liability or responsibility (to the other or anyone claiming through or under the other by way of subrogation or otherwise) for any loss to or damage of property covered by the fire and extended coverage insurance policies insuring the Premises and any of Tenant's property, even if such loss or damage shall have been caused by the fault or negligence of the other party.

9.05 ***Indemnification With Respect to Landlord*** Except to the extent liability has been waived above, Tenant shall indemnify and hold Landlord harmless against any and all claims, liabilities, damages or losses, and any attorney's fees and other incidental expenses, resulting from injury or death of any person or damage to property occurring on or about the Premises and arising in conjunction with the use and occupancy of the Premises, by Tenant or others claiming under Tenant, unless the death, injury or damage was sustained as a result of any willful act of Landlord or its employees, or by reason of the breach of any of Landlord's obligations under this Lease.

9.06 ***Indemnification With Respect to Tenant*** Except to the extent liability has been waived above, Landlord shall indemnify and hold Tenant harmless against any and all claims, liabilities, damages or losses, and any attorney's fees and other incidental expenses, resulting from injury or death of any person or damage to property occurring on or about the Premises and arising in conjunction with the use and occupancy of the Premises, by Landlord during periods of non use by Tenant, or others claiming under Landlord, unless the death, injury or damage was sustained as a result of any willful act of Tenant or its employees, or by reason of the breach of any of Tenant's obligations under this Lease.

ARTICLE X **USE OF PROPERTY BY TENANT**

10.01 ***Specific Use.*** The Premises shall be occupied and used by Tenant exclusively as office and

classroom facilities for elementary and middle school educational grades as maintained and operated by Tenant and for no other purpose. The facility shall be known as 'The Edge Academy.'

10.02 Tenant shall have exclusive use of the Premises at all times. Landlord shall not use, schedule or permit any other person to use or schedule for use the Premises during such times without obtaining the written consent of Tenant at least Fifteen (15) days prior to such use, which consent shall not be unreasonably withheld.

Landlord may use, or may permit others to use the Premises for activities which are sponsored and conducted by Landlord as part of Landlord's normal operations with Tenant's consent, provided that, such use occurs at a time period approved by Tenant and further provided that such use does not unreasonably interrupt or interfere with Tenant's use.

Landlord shall be responsible for restoration of the Premises to their condition as existed prior to Landlord's use. Such restoration shall be completed prior to the next period for which Tenant is scheduled to use the Premises.

Nothing herein shall give Tenant the right to use the Premises for any other purpose or to sublease, assign, or license the use of the Premises to any sub-lessee, assignee, or licensee, which or who shall use the Premises for any other use without the prior written consent of Landlord, which consent may be withheld in its sole discretion.

ARTICLE XI **SIGNAGE**

11.01 *Exterior Signs.* Tenant shall have the right, at its sole risk and expense and in conformity with applicable laws and ordinances, to erect and thereafter, to repair or replace, if it shall so elect signs on any portion of the Premises, providing that Tenant shall remove any such signs upon termination of this lease, and repair all damage occasioned thereby to the Premises.

11.02 *Interior Signs.* Tenant shall have the right, at its sole risk and expense and in conformity with applicable laws and ordinances, to erect, maintain, place and install its usual and customary signs and fixtures in the interior of the Premises.

11.03 *Non Permanent Exterior and Interior Signs.* Tenant shall have the right, at its sole risk and expense and in conformity with applicable laws and ordinances, to erect, maintain, place and install usual and customary signs and fixtures either in the interior of the Premises or on the exterior of the Premises. Such signs shall be placed by Tenant as may be needed in the normal course of operation of the activities of Tenant and shall be removed as soon as possible after the need for such signs has expired.

ARTICLE XII **DAMAGE TO PREMISES**

12.01 *Abatement or Adjustment of Rent.* If the whole or any part of the Premises shall be damaged or destroyed by fire or other casualty after the execution of this Lease and before the termination hereof, Landlord may terminate this Lease effective the date of such casualty. The Landlord shall make its election within thirty (30) days after the occurrence of the casualty. If the Landlord does

not terminate this Lease, then in every case the rent reserved in Article III herein and other charges, if any, shall be abated or adjusted, as the case may be, in proportion to that portion of the Premises of which Tenant shall be deprived on account of such damage or destruction and the work of repair, restoration, rebuilding, or replacement or any combination thereof, of the improvements so damaged or destroyed, shall in no way be construed by any person to effect any reduction of sums or proceeds payable under any rent insurance policy.

12.02 *Repairs and Restoration.* Provided Landlord has not terminated this Lease as provided in Section 12.01, Landlord agrees that in the event of the damage or destruction of the Premises, Landlord forthwith shall proceed to repair, restore, replace or rebuild the Premises (excluding Tenant's leasehold improvements), to substantially the condition in which the same were immediately prior to such damage or destruction. The Landlord thereafter shall diligently prosecute said work to completion without delay or interruption except for events beyond the reasonable control of Landlord. Notwithstanding the foregoing, if Landlord does not either obtain a building permit within ninety (90) days of the date of such damage or destruction, or complete such repairs, rebuilding or restoration within nine (9) months of such damage or destruction, then Tenant may at any time thereafter cancel and terminate this Lease by sending ninety (90) days written notice thereof to Landlord, or, in the alternative, Tenant may, during said ninety (90) day period, apply for the same and Landlord shall cooperate with Tenant in Tenant's application. Notwithstanding the foregoing, if the amount of such damage or destruction occurs during the last three (3) months of the term of this Lease and the amount of damages is at least fifty percent (50%) or more of the replacement cost, (exclusive of the land and foundations), this Lease, except as hereinafter provided in Section 3 of Article XIV, may be terminated at the election of either Landlord or Tenant, provided that notice of such election shall be sent by the party so electing to the other within thirty (30) days after the occurrence of such damage or destruction. Upon termination, as aforesaid, by either party hereto, this Lease and the term thereof shall cease and come to an end, any unearned rent or other charges paid in advance by Tenant shall be refunded to Tenant, and the parties shall be released hereunder, each to the other, from all liability and obligations hereunder thereafter arising.

ARTICLE XIII **CONDEMNATION**

13.01 *Total Taking.* If, after the execution of this Lease and prior to the expiration of the term hereof, the whole of the Premises shall be taken under power of eminent domain by any public or private authority, or conveyed by Landlord to said authority in lieu of such taking, then this Lease and the term hereof shall cease and terminate as of the date when possession of the Premises shall be taken by the taking authority and any unearned rent or other charges, if any, paid in advance, shall be refunded to Tenant.

13.02 *Partial Taking.* If, after the execution of this Lease and prior to the expiration of the term hereof, any public or private authority shall, under the power of eminent domain, take, or Landlord shall convey to said authority in lieu of such taking, property which results in a reduction by ten percent (10%) or more of the area in the Premises, or of a portion of the Premises that substantially interrupts or substantially obstructs the conducting of business on the Premises; then Tenant or Landlord may, at its election, terminate this Lease by giving the other notice of the exercise of its election within thirty (30) days after receipt of notice of such taking. In the event of termination under the provisions of this Section, this Lease and the term hereof shall cease and terminate as of the date when possession shall be taken by the appropriate authority of that portion of the entire property that results in one of the above takings, and any unearned rent or other charges, if

any, paid in advance by Tenant shall be refunded to Tenant.

13.03 Restoration. Provided the Landlord or Tenant shall not have terminated this Lease or in the event of a taking in respect of which Tenant shall not have the right to elect to terminate this Lease, this Lease and the term thereof shall continue in full force and effect and Landlord, at Landlord's sole cost and expense, forthwith shall restore the remaining portions of the Premises, including any and all improvements made theretofore to an architectural whole in substantially the same condition that the same were in prior to such taking. A just proportion of the rent reserved herein and any other charges payable by Tenant hereunder, according to the nature and extent of the injury to the Premises and to Tenant's business, shall be suspended or abated until the completion of such restoration and thereafter the rent and any other charges shall be reduced in proportion to the square footage of the Premises remaining after such taking.

13.04 Condemnation Awards. All compensation awarded for any taking, whether for the whole or a portion of the Premises, shall be the sole property of the Landlord whether such compensation shall be awarded for diminution in the value of, or loss of, the leasehold or for diminution in the value of, or loss of, the fee in the Premises, or otherwise. The Tenant hereby assigns to Landlord all of Tenant's right and title to and interest in any and all such compensation. However, the Landlord shall not be entitled to and Tenant shall have the sole right to make its independent claim for and retain any portion of any award made by the appropriating authority directly to Tenant for loss of business, or damage to or depreciation of, and cost of removal of fixtures, personalty and improvements installed in the Premises by, or at the expense of Tenant, and to any other award made by the appropriating authority directly to Tenant.

13.05 Release. In the event of any termination of this Lease as the result of the provisions of this Article XIII, the parties, effective as of such termination, shall be released, each to the other, from all liability and obligations thereafter arising under this lease.

ARTICLE XIV **DEFAULT**

14.01 Default. The following events shall constitute a default under this Lease and shall give rise to the remedies set forth herein:

- (a) Tenant shall be in default in the payment of rent or other charges herein required to be paid by Tenant; (default herein being defined as payment received by Landlord five (5) or more days subsequent to the due date); or
- (b) Either party has caused a lien to be filed against the other party's property and said lien is not removed within Sixty (60) days of recordation thereof; or,
- (c) Either party shall be in default of the observance or performance of any of the covenants and agreements required to be performed and observed by such party hereunder, if, such default continues for a period of thirty (30) days after written notice of such default is sent to the defaulting party, (or if such default shall reasonably take more than thirty (30) days to cure, the defaulting party has not commenced to actively cure the default within the thirty (30) days and diligently prosecuted the same to completion); or
- (d) Sixty (60) days have elapsed after the commencement of any proceeding by or against either party, whether by the filing of a petition or otherwise, seeking any reorganization,

arrangement, composition, readjustment, liquidation, dissolution or similar relief under the present or future Federal Bankruptcy Act or any other present or future applicable federal, state or other statute or law, whereby such proceeding shall not have been dismissed; or

- (e) Tenant is declared insolvent or adjudged bankrupt, or makes a general assignment for the benefit of its creditors.
- (f) Any of the staff of Edge Learning, Inc. dba The Edge Academy, whether teaching or non-teaching, join or become a member of an organized labor union or entity.

14.02 Remedies:

- (a) Termination of this Lease by the defaulting party by giving written notice of termination as provided in Section 18.02, in which event this Lease shall expire and terminate on the date specified in such notice of termination, with the same force and effect as though the date so specified were the date herein originally fixed as the termination date of the term of this Lease. All rights of Tenant under this Lease and in and to the Premises shall expire and terminate, and Tenant shall remain liable for all obligations under this Lease arising up to the date of such termination, and Tenant shall surrender the Premises to Landlord on the date specified in such notice; or
- (b) In the event of a default by Tenant, without terminating this Lease, and with or without notice to Tenant, Landlord may enter into and upon and take possession of the Premises or any part thereof, and Tenant must continue to pay rent under the terms of this Lease, and, at Landlord's option, remove persons and property therefrom, and such property, if any, may be removed and stored in a warehouse or elsewhere at the cost of, and for the account of Tenant, all without being deemed guilty of trespass or becoming liable for any loss or damage which may be occasioned thereby, and Landlord may rent the Premises or any portion thereof with or without advertisement, and by private negotiations and for any term upon such terms and conditions as Landlord may deem necessary or desirable in order to relet the Premises. Landlord shall in no way be responsible or liable for any rental concessions or any failure to rent the Premises or any part thereof, or for any failure to collect any rent due upon such reletting. Upon such reletting, all rentals received by Landlord from such reletting shall be applied: first, to the payment of any indebtedness (other than any rent due hereunder) from Tenant to Landlord; second, to the payment of rent and other charges then due and unpaid hereunder; third, to the payment of any costs and expenses of such reletting, including, without limitation, brokerage fees and attorney's fees and costs of alterations and repairs; and, the residue, if any shall be held by Landlord to the extent of and for application in payment of future rent as the same may become due and payable hereunder. In reletting the Premises as aforesaid, Landlord may grant rent concessions and Tenant shall not be credited therefor. If such rentals received from such reletting shall at any time or from time to time be less than sufficient to pay to Landlord the entire sums then due from Tenant hereunder, Tenant shall pay any such deficiency to Landlord. Such deficiency shall, at Landlord's option, be calculated and paid monthly. No such reletting shall be construed as an election by Landlord to terminate this Lease unless a written notice of such election has been given to Tenant by Landlord. Notwithstanding any such reletting without termination, Landlord may at any time thereafter elect to terminate this Lease for any such previous default provided same has not been cured; or

- (c) In the event of a default by Tenant, the Landlord without liability to Tenant or any other party and without constituting a constructive or actual eviction, suspend or discontinue furnishing or rendering to Tenant any property, material, labor, utilities or other service, whether Landlord is obligated to furnish or render the same, so long as Tenant is in default under this Lease; or
- (d) The pursuit of any remedy of remedies, including without limitation, any one or more of the remedies stated herein shall not (1) constitute an election of remedies or preclude pursuit of any other remedy or remedies provided in this Lease or any other remedy or remedies provided by law or in equity, separately or concurrently or in any combination, or (2) serve as the basis for any claim of constructive eviction, or allow Tenant to withhold any payments under this Lease.

14.02 Cure of Default by LANDLORD. If the Tenant defaults in the performance or observance of any agreement or condition in this Lease and does not cure such default within thirty (30) days after written notice from Landlord specifying the default (or if such default shall reasonably take more than thirty (30) days to cure, begins such cure within Thirty (30) days and diligently prosecutes the same to completion), Landlord may, at its option, without waiving any claim for damages for breach of agreement, at any time thereafter cure such default for the account of Tenant. Any amount paid or contractual liability incurred by Landlord in so doing shall be deemed paid or incurred for the account of Tenant and Tenant agrees to reimburse Landlord therefor and save Landlord harmless therefrom. Provided, however, that Landlord may cure any such default as aforesaid prior to the expiration of said waiting period, without notice to Tenant if any emergency situation exists, or after notice to Tenant, if the curing of such default prior to the expiration of said waiting period is reasonably necessary to protect the Premises or Landlord's interest therein, or to prevent injury or damage to persons or property. If Tenant shall fail to reimburse Landlord upon demand for any amount paid for the account of Tenant hereunder, said amount shall be added to and become due as a part of the next payment of rent due and shall for all purposes be deemed and treated as rent hereunder.

14.03 Cure of Default by Tenant If Landlord defaults in the performance or observance of any agreement or condition in this Lease contained on its part to be performed or observed, and if Landlord does not cure such default within thirty (30) days after written notice from Tenant specifying the default (or, if such default shall reasonably take more than thirty (30) days to cure, and Landlord shall not have commenced the same within the thirty (30) days and diligently prosecuted the same to completion), Tenant may, at its option, without waiving any claim for damages for breach of agreement, at any time thereafter cure such default for the account of Landlord and any amount paid or any contractual liability incurred by Tenant in so doing shall be deemed paid or incurred for the account of Landlord. Landlord shall reimburse Tenant therefor and save Tenant harmless therefrom; provided, however, that Tenant may cure any such default as aforesaid prior to the expiration of said waiting period, without notice to Landlord if an emergency situation exists, or after notice to Landlord, if the curing of such default prior to the expiration of said waiting period is reasonably necessary to protect the Premises or Tenant's interest therein or to prevent injury or damage to persons or property. If Landlord shall fail to reimburse Tenant upon demand for any amount paid or liability incurred for the account of Landlord hereunder, said amount or liability may be deducted by Tenant from the next or any succeeding payments of rent due hereunder; provided, however, that should said amount or the liability therefor be disputed by Landlord, Landlord may contest its liability or the amount thereof,

through arbitration or through a declaratory judgment action and Landlord shall bear the cost of the filing fees therefore.

14.04 ***TENANT'S Right to cure LANDLORD'S Default.*** In the event that Landlord shall fail, refuse or neglect to pay any mortgages, liens or encumbrances, the judicial sale of which might affect the interest of Tenant hereunder, or shall fail, refuse or neglect to pay any interest due or payable on any such mortgage, lien or encumbrance, Tenant may pay said mortgages, liens or encumbrances, or interest or perform said conditions and charge to Landlord the amount so paid and withhold and deduct from any rents herein reserved such amounts so paid, and any excess over and above the amounts of said rents shall be paid by Landlord to Tenant.

ARTICLE XV
TITLE

15.01 ***Subordination.*** Tenant shall, upon the request of Landlord in writing, subordinate this Lease to the lien of any present or future institutional mortgage upon the Premises irrespective of the time of execution or the time of recording of any such mortgage. Provided, however, that as a condition to such subordination, the holder of any such mortgage shall enter first into a written agreement with Tenant in form suitable for recording to the effect that:

- (a) In the event of foreclosure or other action taken under the mortgage by the holder thereof, this Lease and the rights of Tenant hereunder shall not be disturbed but shall continue in full force and effect so long as Tenant shall not be in default hereunder, and
- (b) Such holder shall permit insurance proceeds and condemnation proceeds to be used for any restoration and repair required by the provisions of Articles XII, XIII or XIV, respectively. Tenant agrees that if the mortgagee or any person claiming under the mortgage shall succeed to the interest of Landlord in this Lease, Tenant will recognize said mortgagee or person as its Landlord under the terms of this Lease, provided that said mortgagee or person for the period during which said mortgagee or person respectively shall be in possession of the Premises and thereafter their respective successors in interest shall assume all of the obligations of Landlord hereunder. The word "mortgage", as used herein includes mortgages, deeds of trust or other similar instruments, and modifications, and extensions thereof. The term "institutional mortgage" as used in this Article XV means a mortgage securing a loan from a bank (commercial or savings) or trust company, insurance company or pension trust or any other lender institutional in nature and constituting a lien upon the Premises.

15.02 ***Quiet Enjoyment.*** Landlord covenants and agrees that upon Tenant paying the rent and observing and performing all of the terms, covenants and conditions on Tenant's part to be observed and performed hereunder, that Tenant may peaceably and quietly have, hold, occupy and enjoy the Premises in accordance with the terms of this Lease without hindrance or molestation from Landlord or any persons lawfully claiming through Landlord

15.03 ***Good Title.*** Landlord warrants and represents, upon which warranty and representation Tenant has relied in the execution of this Lease, that Landlord is the owner of the Premises, in fee simple absolute, free and clear of all encumbrances, except for the easements, covenants and restrictions of record as of the date of this Lease. Such exceptions shall not impede or interfere with the quiet use and enjoyment of the Premises by Tenant. Landlord further warrants and covenants that this Lease is and shall be a first lien on the Premises, subject only to any

Mortgage to which this Lease is subordinate or may become subordinate pursuant to an agreement executed by Tenant, and to such encumbrances as shall be caused by the acts or omissions of Tenant; that Landlord has full right and lawful authority to execute this Lease for the term, in the manner, and upon the conditions and provisions herein contained.

15.04 Licenses. It shall be the Tenant's responsibility to obtain any and all necessary licenses and the Landlord shall bear no responsibility therefor; the Tenant shall promptly notify Landlord of the fact that it has obtained the necessary licenses in order to prevent any delay to Landlord in commencing construction of the Premises.

ARTICLE XVI EXTENSIONS/WAIVERS/DISPUTES

16.01 Hold Over. In the event that Tenant or anyone claiming under Tenant shall continue occupancy of the Premises after the expiration of the term of this Lease without any agreement in writing between Landlord and Tenant with respect thereto, such occupancy shall not be deemed to extend or renew the term of the Lease, but such occupancy shall continue as a tenancy at will, from month to month, upon the covenants, provisions and conditions herein contained at the rate as set forth in this agreement; provided that, if the Landlord has demanded the surrender of the Premises by Tenant in writing any the rate of rent for any holdover beginning with the next immediately following month shall be at a rate of One Hundred Fifty Percent, (150%) of the rate set forth herein.

16.02 Waivers. Failure of either party to complain of any act or omission on the part of the other party, no matter how long the same may continue, shall not be deemed to be a waiver by said party of any of its rights hereunder. No waiver by either party at any time, express or implied, of any breach of any provision of this Lease shall be deemed a waiver of a breach of any other provision of this Lease or a consent to any subsequent breach of the same or any other provision. If any action by either party shall require the consent or approval of the other party, the other party's consent to or approval of such action on any one occasion shall not be deemed a consent to or approval of said action on any subsequent occasion or a consent to or approval of any other action on the same or any subsequent occasion. Any and all rights and remedies which either party may have under this Lease or by operation of law, either at law or in equity, upon any breach, shall be distinct, separate and cumulative and shall not be deemed inconsistent with each other, and no one of them, whether exercised by said party or not, shall be deemed to be an exclusion of any other; and any two or more or all of such rights and remedies may be exercised at the same time.

16.03 Disputes. It is agreed that, if at any time a dispute shall arise as to any amount or sum of money to be paid by one party to the other under the provisions hereof, the party against whom the obligation to pay the money is asserted shall have the right to make payment "under protest" and such payment shall not be regarded as a voluntary payment and there shall survive the right on the part of the said party to institute suit for the recovery of such sum. If it shall be adjudged that there was no legal obligation on the part of said party to pay such sum or any part thereof, said party shall be entitled to recover such sum or so much thereof as it was not legally required to pay under the provisions of this Lease. If at any time a dispute shall arise between the parties hereto as to any work to be performed by either of them under the provisions hereof, the party against whom the obligation to perform the work is asserted may perform such work and pay the costs thereof "under protest" and the performance of such work shall in no event be regarded as a voluntary performance and shall survive the right on the part of the said party to institute suit for

the recovery of the costs of such work If it shall be adjudged that there was no legal obligation on the part of the said party to perform the same or any part thereof, said party shall be entitled to recover the costs of such work or the cost of so much thereof as said party was not legally required to perform under the provisions of this Lease and the amount so paid by Tenant may be withheld or deducted by Tenant from any rents herein reserved.

16.04 **Notices.** All notices and other communications authorized or required hereunder shall be in writing and shall be given by personal delivery or mailing the same by certified mail, return receipt requested, postage prepaid, and any such notice or other communication shall be deemed to have been given when received by the party to whom such notice or other communication shall be addressed. If intended for Landlord the same will be mailed to the address herein above set forth or such other address as Landlord may hereafter designate by notice to Tenant, and if intended for Tenant, the same shall be mailed to Tenant at the address herein above set forth, or such other address or addresses as Tenant may hereafter designate by notice to Landlord.

ARTICLE XVII **PROPERTY DAMAGE**

17.01 **Loss and Damage.** Notwithstanding any contrary provisions of this Lease, Landlord shall not be responsible for any loss of or damage to property of Tenant or of others located on the Premises, except where caused by the willful act or omission of Landlord, or Landlord's agents, employees or contractors, provided, however, that if Tenant shall notify Landlord in writing of repairs which are the responsibility of Landlord under Article VII hereof, and Landlord shall fail to commence and diligently prosecute to completion said repairs promptly after such notice, and if after the giving of such notice and the occurrence of such failure, loss of or damage to Tenant's property shall result from the condition as to which Landlord has been notified, Landlord shall indemnify and hold harmless Tenant from any loss, cost or expense arising therefrom.

17.02 **Force Majeure.** In the event that Landlord or Tenant shall be delayed or hindered in or prevented from the performance of any act other than Tenant's obligation to make payments of rent, additional rent, and other charges required hereunder, by reason of strikes, lockouts, unavailability of materials, failure of power, restrictive governmental laws or regulations, riots, insurrections, the act, failure to act, or default of the other party, war or other reason beyond its control, then performance of such act shall be excused for the period of the delay and the period for the performance of such act shall be extended for a period equivalent to the period of such delay.

ARTICLE XVIII **TERMINATION OF LEASE**

18.01 **Termination by Mutual Consent.** Upon the mutual agreement by the parties hereto, this Lease shall terminate at such time and upon such terms as the parties set forth in writing and which is executed by both parties as "evidence" of their mutual agreement.

18.02 **Termination Upon Default by Tenant or Landlord** In the event of a default by Tenant, pursuant to Article XIV, the Landlord may elect to terminate the lease as provided for in Article XIV by providing written notice at least five (5) days prior to the date of termination. In the event of default by Landlord, Tenant may elect to terminate the lease as provided for in Article XIV by providing written notice at least five (5) days prior to the date of termination.

18.03 **No Termination Upon Failure to Finalize Contract** The Parties hereto agree that the operation

of a community school by Edge Learning, Inc., is not, a condition which will cause a termination of this Lease. Accordingly, this Lease shall not terminate in the event that Edge Learning, Inc., does not finalize or renew, (as the case may be), the contract by and between Edge Learning, Inc. and the Sponsor and/or The Ohio Department of Education for the operation of a community school by Edge Learning, Inc., nor in any case where Edge Learning Inc., ceases the operation of a community school. In such case this Lease shall remain in full force and effect.

ARTICLE XIX **MISCELLANEOUS**

- 19.01** ***Assignment and Subletting.*** Under the terms and conditions hereunder, Tenant shall not have the right to transfer and assign this lease or to sublet all or any portion of the Premises, without the prior written consent of Landlord. Landlord may sell, exchange, transfer, assign or hypothecate this Lease at any time without Tenant's consent; provided that such sale, exchange, transfer, assignment or hypothecation shall be made with respect to the entire Lease.
- 19.02** ***Fixtures.*** All personal property, furnishings and equipment presently and all other trade fixtures installed in or hereafter by or at the expense of Tenant and all additions and/or improvements, exclusive of structural, mechanical, electrical, and plumbing, affixed to the Premises and used in the operation of the Tenant's business made to, in or on the Premises by and at the expense of Tenant and susceptible of being removed from the Premises without damage, unless such damage be repaired by Tenant, shall remain the property of Tenant and Tenant upon the request of Landlord shall be obligated to, remove the same or any part thereof at any time or times during the term hereof, provided that Tenant, at its sole cost and expense, shall make any repairs occasioned by such removal.
- 19.03** ***Estoppel Certificates.*** At any time and from time to time, Landlord and Tenant each agree, upon request in writing from the other, to execute, acknowledge and deliver to the other or to any person designated by the other a statement in writing certifying that the Lease is unmodified and is in full force and effect, or if there have been modifications, that the same is in full force and effect as modified (stating the modifications), that the other party is not in default in the performance of its covenants hereunder, or if there have been such defaults, specifying the same, and the dates to which the rent and other charges have been paid.
- 19.04** ***Invalidity of Particular Provision.*** If any term or provision of this Lease or the application hereof to any person or circumstance shall, to any extent, be held invalid or unenforceable, the remainder of this Lease, or the application of such term or provision to persons or circumstances other than those as to which it is held invalid or unenforceable, shall not be affected thereby, and each term and provision of this Lease shall be valid and be enforced to the fullest extent permitted by law.
- 19.05** ***Captions and Definitions of Parties.*** The captions of the Sections of this Lease are for convenience only and are not a part of this Lease and do not in any way limit or amplify the terms and provisions of this Lease. The word "Landlord" and the pronouns referring thereto, shall mean, where the context so admits or requires, the persons, firm or corporation named herein as Landlord or the mortgagee in possession at any time, of the land and building comprising the Premises. If there is more than one Landlord or Tenant, the covenants of Landlord or Tenant shall be the joint and several obligations of each of them, and if Landlord or Tenant is a partnership, the covenants of Landlord shall be the joint and several obligations of each of the

partners and the obligations of the firm. Any pronoun shall be read in the singular or plural and in such gender as the context may require. Except as in this Lease otherwise provided, the terms and provisions of this Lease shall be binding upon and inure to the benefit of the parties hereto and their respective successors and assigns.

Nothing contained herein shall be deemed or construed by the parties hereto nor by any third party as creating the relationship of principal and agent or of partnership or of a joint venture between the parties hereto, it being understood and agreed that neither any provision contained herein, nor any acts of the parties hereto, shall be deemed to create any relationship between the parties hereto other than the relationship of Landlord and Tenant.

19.06 Brokerage. No party has acted as, by or through a broker in the effectuation of this Agreement, except as set out hereinafter.

19.07 Surrender Upon the expiration or earlier termination of this Lease, Tenant shall surrender to Landlord the Premises in good condition and repair, ordinary wear and tear excepted.

19.08 Entire Agreement. This instrument contains the entire and only agreement between the parties, and no oral statements or representations or prior written matter not contained in this instrument shall have any force and effect. This Lease shall not be modified in any way except by a writing executed by both parties.

19.09 Governing Law. All matters pertaining to this agreement (including its interpretation, application, validity, performance and breach) in whatever jurisdiction action may be brought, shall be governed by, construed and enforced in accordance with the laws of the State of Ohio.

19.10 Liability of LANDLORD. Notwithstanding anything to the contrary in this Lease, if Landlord fails to perform any of its obligations under this Lease, and, as a consequence of this default, Tenant recovers a money judgment against Landlord, that judgment shall be first satisfied from the general assets of the Landlord.

IN WITNESS WHEREOF, the undersigned have executed this Lease Agreement as of the date set forth on page 1.

CHARTER DEVELOPMENT
FOUNDATION, INC.

By: 

Its: TRUSTEE

The Edge Academy

By: 

Its: Board President

Witness 

Witness 

FIRE AND WEATHER EMERGENCY EVACUATION PLAN

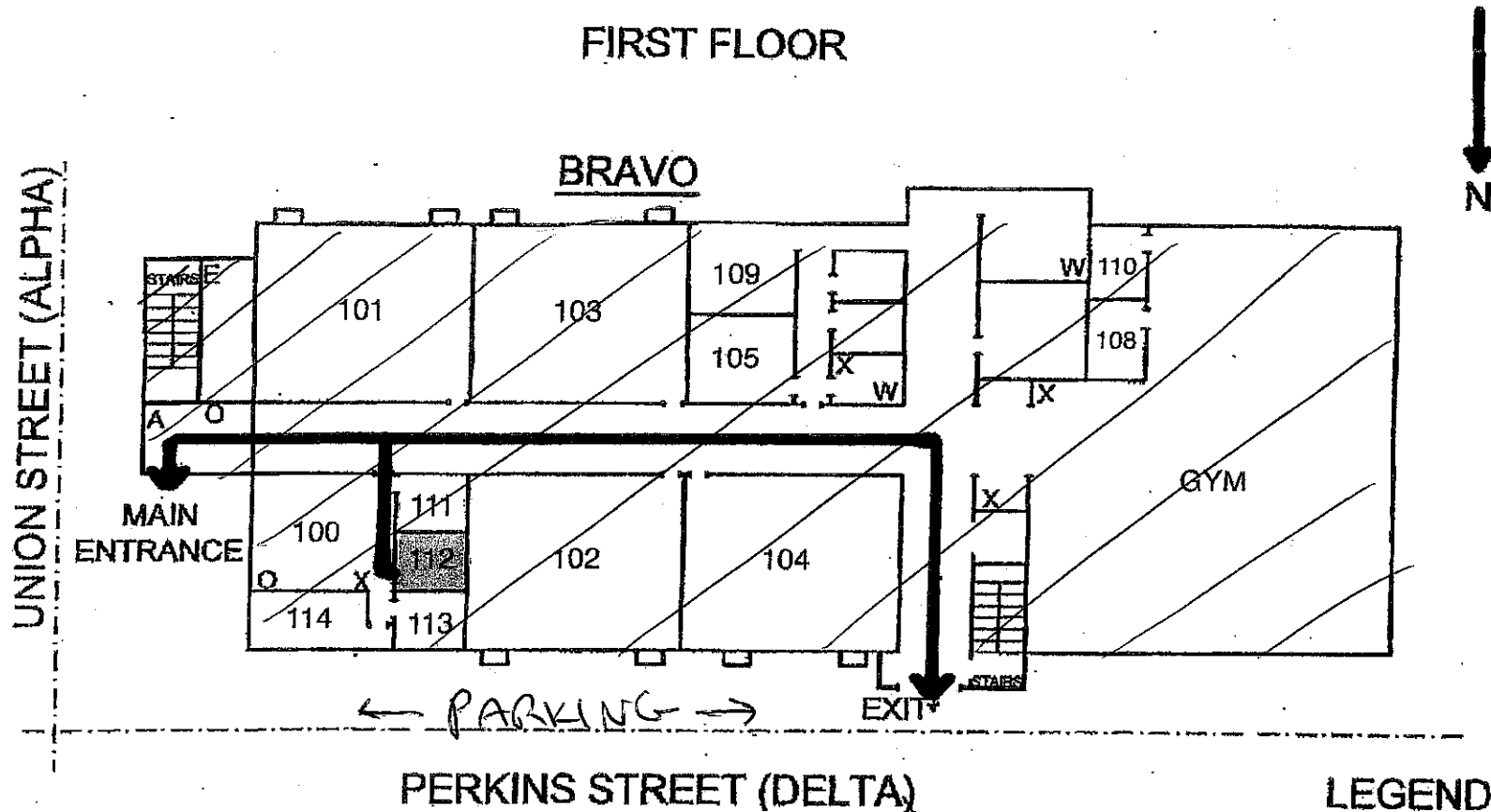

THE EDGE ACADEMY

EXHIBIT A

92 NORTH UNION STREET
AKRON, OHIO 44304

EMERGENCY MAINTENANCE # 234-205-7166

IRN: 133538

LEGEND

- O - CAMERA
- G - GAS SHUT OFF
- W - WATER SHUT OFF
- E - ELECTRICAL SHUT OFF
- X - FIRE EXTINGUISHER
- A - ALARM PANEL
- D - AED

FIRE AND WEATHER EMERGENCY EVACUATION PLAN

SECOND FLOOR

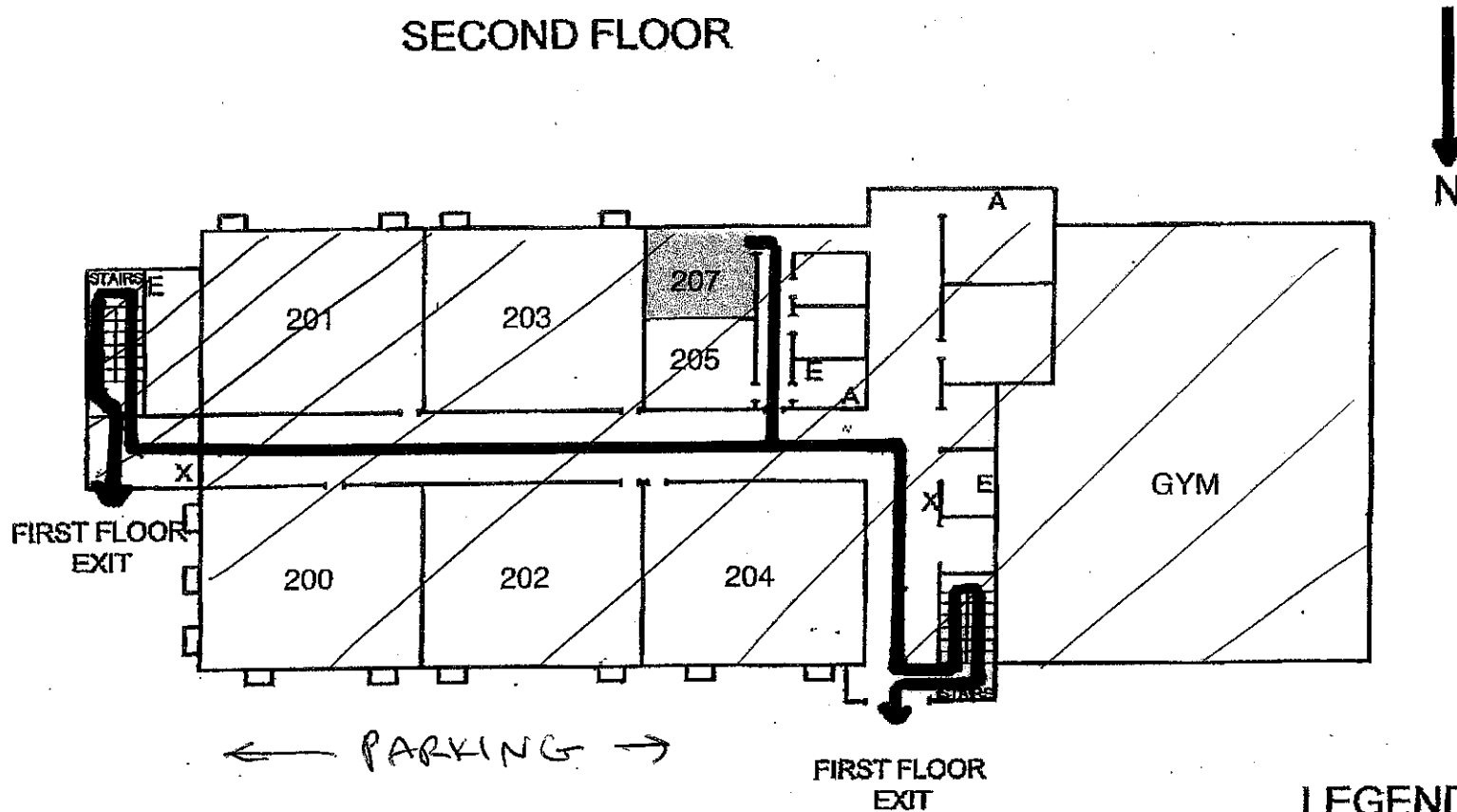

LEGEND

- O - CAMERA
- G - GAS SHUT OFF
- W - WATER SHUT OFF
- E - ELECTRICAL SHUT OFF
- X - FIRE EXTINGUISHER
- A - ALARM PANEL
- D - AED

THE EDGE ACADEMY

92 NORTH UNION STREET
AKRON, OHIO 44304

EMERGENCY MAINTENANCE #234-205-7166

IRN: 133538

Exhibit A

LEASE AGREEMENT

THIS LEASE AGREEMENT ("Lease") is made and entered into this ____1st____ day of July, 2022, by and between **Edge Learning Inc.**, an Ohio not for profit corporation, whose principal place of business is 92 North Union, Akron Ohio 44304, (hereinafter referred to as "Tenant"), and **CHARTER DEVELOPMENT FOUNDATION, INC.**, an Ohio nonprofit corporation, whose principal place of business is 265 Park St, Akron, Ohio 44304 (hereinafter referred to as "Landlord").

ARTICLE I GRANT OF LEASE

1.01 Landlord, in consideration of the rents to be paid and the covenants and agreements to be performed and observed by the Tenant, does hereby lease to the Tenant and the Tenant does hereby lease and take from the Landlord that portion of the building located at 280 Perkins, Akron, Ohio, 44304 consisting of approximately 16,995 of 16,995 square feet and being shown by the cross-hatched section on Exhibit A attached hereto and by reference made a part hereof (the "Premises"). Landlord additionally grants to Tenant during the term of this Lease, the right to use in common with Landlord and other occupants of the building (a) all easements and rights appurtenant to the property, (b) all portions of the building (if any) designed for the common use of all occupants of the building, and (c) all common areas and designated parking areas as shown on Exhibit A. Tenant's use of the Premises shall be subject to such reasonable rules and regulations as Landlord may adopt from time to time.

ARTICLE II LEASE TERM AND CONDITION OF PREMISES

2.01 ***Total Term of Lease.*** The term of this Lease shall begin on the Commencement Date, as defined in Section 2.02 of this Article II. and shall terminate on June 30, 2025.

2.02 ***Commencement Date.*** The "Commencement Date" shall mean July 1, 2022, or if later, the date on which the Tenant shall commence to conduct business on the Premises, so long as such date is not in excess of ninety (90) days subsequent to execution hereof.

2.03 ***Condition of Premises.*** Tenant acknowledges that it has inspected the Premises, found the same to be satisfactory and accepts the same in its "AS IS" present condition.

ARTICLE III RENT

3.01 The Tenant agrees to pay the Landlord and the Landlord agrees to accept, during the term hereof, at the Landlord's principal place of business or at such place as the Landlord shall from time to time direct by written notice to the Tenant, rent at the following rates and times:

(a) ***Annual Rent.*** Annual rent for the term of the Lease shall be One Hundred Eighty-Six Thousand Nine Hundred Forty-Five Dollars (\$186,945).

(b) ***Payment of Annual Rent.*** The annual rent shall be payable in advance in equal monthly installments of one-twelfth (1/12th) of the total yearly rent, which shall be equal to Fifteen Thousand Five Hundred Seventy-Eight and 75/100 Dollars, (\$15,578.75) per month,

beginning on the Commencement Date and continuing on the first day of each and every calendar month during the term hereof. In the event the Lease commences on a day other than the first day of a month, rent shall be prorated for each fractional part of a month for which the Tenant actually occupies and utilizes the Premises. If any installment of rent is not fully paid within five (5) days after the due date, a late charge of five percent (5%) of the amount due shall be due Landlord as additional rent to compensate Landlord for loss and expense occasioned by the delinquency in payment.

Reference to Annual Rent hereunder shall not be implied or construed to the effect that this Lease or the obligation to pay rent hereunder is from year to year, or for any term shorter than the existing Lease term.

ARTICLE IV **SECURITY DEPOSIT**

4.01 The Tenant shall not be required to make any deposit or provide any other collateral as security for the full and faithful performance by the Tenant of all the terms of this lease required to be performed by the Tenant.

ARTICLE V **TAXES**

5.01 *Personal Property Taxes.* The Landlord shall be liable for all taxes levied against any leasehold interest of the Tenant, however the Tenant shall be liable for and shall pay when due, taxes upon personal property and trade fixtures owned and placed in the Premise by the Tenant.

5.02 *Real Estate Taxes.* During the continuance of this lease Tenant shall pay, all real estate taxes and assessments applicable to the Premises, together with any interest and penalties lawfully imposed thereon, which may be levied upon the Premises during the term of this Lease.

5.03 *Contest of Taxes.* The Tenant, at its own cost and expense, may, if it shall in good faith so desire, contest by appropriate proceedings the amount of any personal property tax. Landlord may, if it shall so desire, endeavor at any time or times, by appropriate proceedings, to obtain a reduction in the assessed valuation of the Premises for tax purposes. In any such event, the Landlord and Tenant agree that, at the request of the Landlord, the Tenant will sign and deliver such papers and instruments as may be necessary to enable the Landlord to prosecute such proceedings.

5.04 *Payment of Ordinary Assessments.* The Tenant shall pay all assessments, ordinary and extraordinary, attributable to or against the Premises.

5.05 *Other Taxes.* The Landlord and Tenant agree that any liability for income, franchise, or excise taxes that may be imposed, (including but not limited to Federal Income Tax, the Tax on Prohibited Transactions, or the Tax on Unrelated Taxable Business Income), shall be solely the liability and responsibility of the party upon whom such liability is imposed and accordingly neither party shall be liable for such taxes assessed against the other party.

ARTICLE VI **UTILITIES**

6.01 *Utilities.* Tenant shall pay for Tenant's reasonable use of water, sanitation, sewer, electricity,

light, heat, gas, power, fuel, janitorial, and other services on the Premises, whether or not the cost thereof be a charge or imposition against the Premises.

ARTICLE VII
OBLIGATIONS FOR REPAIRS AND MAINTENANCE

7.01 ***TENANT'S Repairs and Maintenance – Structural, Exterior and Infrastructure.*** The Tenant shall be required to keep in reasonably good order, condition and repair (i) the roof and all structural elements and portions of the Premises and building, (ii) all exterior elements and portions of the building, (iii) the parking areas, drives and other exterior improvements located on the property, and (iv) any common pipes, conduits, equipment and systems that serve Tenant's space and also serve other parts of the building; subject, however, to ordinary wear and tear.

7.02 ***TENANT'S Repairs and Maintenance.*** Unless otherwise agreed to in writing by Landlord and Tenant, the Tenant shall perform all repairs and maintenance and make all replacements as are necessary to keep in good order, condition and repair, all portions of the interior of the Premises, ordinary wear and tear excepted. Tenant further agrees that it will not cause or permit any waste or damage to the Premises, nor allow the accumulation of boxes, barrels, packages, wastepaper or other trash, it being Tenant's responsibility to provide for its own trash and rubbish removal from the Premises to the designated dumpster. In addition, Tenant at its expense shall repair, replace or restore all damage to the Premises or the building caused by the negligent acts or omissions of Tenant or its agents, employees or invitees. Tenant shall be solely responsible for the maintenance and repair of any special facilities needed for Tenant's operations, including: lawn care and snow removal; and janitorial services and supplies.

7.03 Requirements of the Law. The Tenant agrees that if any federal, state or municipal government or any department or division thereof shall condemn the Premises or any part thereof as not in conformity with the laws and regulations relating to the construction thereof as of the Commencement Date with respect to conditions latent or otherwise which existed on the Commencement Date, or, with respect to items which are the Landlord's duty to repair pursuant to Section 7.01 of this Article VII; and such federal, state or municipal government or any other department or division thereof, has ordered or required, or shall hereafter order or require, any alterations or repairs thereof or installations and repairs as may be necessary to comply with such laws, orders or requirements; and if by reason of such laws, orders or the work done by the Landlord in connection therewith, the Tenant is deprived of the use of the Premises, the rent shall be abated or adjusted, as the case may be, in proportion to that time during which, and to that portion of the Premises of which, the Tenant shall be deprived as a result thereof, and the Landlord shall be obligated to make such repairs, alterations or modifications at Landlord's expense; provided the violation with the laws and regulations is not caused by Tenant's use or occupancy of the Premises for its intended purposes.

7.04 ***TENANT'S Alterations.*** The Tenant shall have the right, at its sole expense, from time to time, to redecorate the Premises and to make such non-structural alterations and changes in such parts thereof as the Tenant shall deem expedient or necessary for its purposes; provided, however, that such alterations and changes shall not impair the structural soundness of the building, diminish the value of the Premises and Tenant shall first obtain Landlord's written consent to make the alterations, additions or improvements, which consent shall not be unreasonably withheld. Notwithstanding the above, the Landlord may withhold its consent if any improvement is found by the Landlord, in its sole discretion, to be against the Landlord's rules and regulations. Upon termination of this Lease, any alterations, additions or improvements made by Tenant shall

become the property of Landlord, excluding trade fixtures which may be removed by Tenant.

7.05 *Permits and Expenses.* Each party agrees that it will procure all necessary permits for making any repairs, alterations, or other improvements for installations, when applicable. Each Party hereto shall give written notice to the other party of any repairs required of the other pursuant to the provisions of this Article and the party responsible for said repairs agrees promptly to commence such repairs and to prosecute the same to completion diligently, subject, however, to the delays occasioned by events beyond the control of such party.

Each party agrees to pay promptly when due the entire cost of any work done by it upon the Premises so that the Premises at all times shall be free of liens for labor and materials. Each party further agrees to hold harmless and indemnify the other party from and against any and all injury, loss, claims or damage to any person or property occasioned by or arising out of the doing of any such work by such party or its employees, agents or contractors. Each party further agrees that in doing such work that it will employ materials of good quality and comply with all governmental requirements, and perform such work in a good and workmanlike manner.

ARTICLE VIII TENANT'S COVENANTS

8.01 *TENANT'S Covenants.* Tenant covenants and agrees as follows:

- (a) To procure any licenses and permits required for any use made of the Premises by Tenant, and upon the expiration or termination of this Lease, to remove its goods and effects and those of all persons claiming under it, and to yield up peaceably to Landlord the Premises in good order, repair and condition in all respects; excepting only damage by fire and casualty covered by Tenant's insurance coverage, structural repairs and reasonable wear and tear;
- (b) To permit Landlord and its agents to examine the Premises at reasonable times and to show the Premises to prospective purchasers of the Building and to provide Landlord, if not already available, with a set of keys for the purpose of said examination, provided that Landlord shall not thereby unreasonably interfere with the conduct of Tenant's business;
- (c) To permit Landlord to enter the Premises to inspect such repairs, improvements, alterations or additions thereto as may be required under the provisions of this Lease. If, as a result of such repairs, improvements, alterations, or additions, Tenant is deprived of the use of the Premises, the rent shall be abated or adjusted, as the case may be, in proportion to that time during which, and to that portion of the Premises of which, Tenant shall be deprived as a result thereof.
- (d) To comply with all present and future laws and regulations applicable to its use and occupancy of the Premises, and to the extent required under Section 7.02, shall make any repairs, modifications, or additions to the Premises that may be required by those laws.

ARTICLE IX INDEMNITY AND INSURANCE

9.01 *Tenant's Public Liability.* Tenant shall maintain, with respect to the Premises, public liability

insurance with limits of not less than One Million Dollars (\$1,000,000.00) combined single limit for injury or death from one accident and Two Hundred Fifty Thousand Dollars (\$250,000.00) property damage insurance, insuring Landlord and Tenant against injury to, or damage to property on or about the Premises. In addition thereto Tenant shall secure umbrella coverage in the amount of at least One Million Dollars (\$1,000,000.00) for general liability which shall insure both Tenant and Landlord. A copy of the policy or a certificate of insurance shall be delivered to Landlord on or before the Commencement Date and no such policy shall be cancelable without ten (10) days prior written notice to Landlord. The Landlord shall be listed as an additional insured on the policies.

9.02 ***Landlord's Public Liability*** Landlord shall maintain at its sole cost and expense public liability insurance, property damage insurance with respect to the Premises in such amounts as it deems appropriate and necessary in the ordinary course of business; provided that such insurance shall not be less than the amount maintained by Tenant under Section 9.01 hereof.

9.03 ***Insurance Proceeds.*** In the event of any damage to or destruction of the Premises, which is recoverable under Tenant's policy of insurance, Tenant shall adjust the loss and settle all claims with the insurance companies issuing such policies. Any insurance proceeds in excess of such proceeds as shall be necessary for such repair, restoration, rebuilding, replacement or any combination thereof shall be the sole property of Tenant.

9.04 ***Co-Insurance/Contribution for Property Damage.*** Landlord and Tenant hereby release each other, to the extent of the insurance coverage required hereunder, or if greater, the amount of actual insurance coverage maintained by the respective parties hereto, from any and all liability or responsibility (to the other or anyone claiming through or under the other by way of subrogation or otherwise) for any loss to or damage of property covered by the fire and extended coverage insurance policies insuring the Premises and any of Tenant's property, even if such loss or damage shall have been caused by the fault or negligence of the other party.

9.05 ***Indemnification With Respect to Landlord*** Except to the extent liability has been waived above, Tenant shall indemnify and hold Landlord harmless against any and all claims, liabilities, damages or losses, and any attorney's fees and other incidental expenses, resulting from injury or death of any person or damage to property occurring on or about the Premises and arising in conjunction with the use and occupancy of the Premises, by Tenant or others claiming under Tenant, unless the death, injury or damage was sustained as a result of any willful act of Landlord or its employees, or by reason of the breach of any of Landlord's obligations under this Lease.

9.06 ***Indemnification With Respect to Tenant*** Except to the extent liability has been waived above, Landlord shall indemnify and hold Tenant harmless against any and all claims, liabilities, damages or losses, and any attorney's fees and other incidental expenses, resulting from injury or death of any person or damage to property occurring on or about the Premises and arising in conjunction with the use and occupancy of the Premises, by Landlord during periods of non use by Tenant, or others claiming under Landlord, unless the death, injury or damage was sustained as a result of any willful act of Tenant or its employees, or by reason of the breach of any of Tenant's obligations under this Lease.

ARTICLE X USE OF PROPERTY BY TENANT

10.01 ***Specific Use.*** The Premises shall be occupied and used by Tenant exclusively as office and

classroom facilities for elementary and middle school educational grades as maintained and operated by Tenant and for no other purpose. The facility shall be known as 'The Edge Academy.'

10.02 Tenant shall have exclusive use of the Premises at all times. Landlord shall not use, schedule or permit any other person to use or schedule for use the Premises during such times without obtaining the written consent of Tenant at least Fifteen (15) days prior to such use, which consent shall not be unreasonably withheld.

Landlord may use, or may permit others to use the Premises for activities which are sponsored and conducted by Landlord as part of Landlord's normal operations with Tenant's consent, provided that, such use occurs at a time period approved by Tenant and further provided that such use does not unreasonably interrupt or interfere with Tenant's use.

Landlord shall be responsible for restoration of the Premises to their condition as existed prior to Landlord's use. Such restoration shall be completed prior to the next period for which Tenant is scheduled to use the Premises.

Nothing herein shall give Tenant the right to use the Premises for any other purpose or to sublease, assign, or license the use of the Premises to any sub-lessee, assignee, or licensee, which or who shall use the Premises for any other use without the prior written consent of Landlord, which consent may be withheld in its sole discretion.

ARTICLE XI **SIGNAGE**

11.01 *Exterior Signs.* Tenant shall have the right, at its sole risk and expense and In conformity with applicable laws and ordinances, to erect and thereafter, to repair or replace, if it shall so elect signs on any portion of the Premises, providing that Tenant shall remove any such signs upon termination of this lease, and repair all damage occasioned thereby to the Premises.

11.02 *Interior Signs.* Tenant shall have the right, at its sole risk and expense and in conformity with applicable laws and ordinances, to erect, maintain, place and install its usual and customary signs and fixtures in the interior of the Premises.

11.03 *Non Permanent Exterior and Interior Signs.* Tenant shall have the right, at its sole risk and expense and in conformity with applicable laws and ordinances, to erect, maintain, place and install usual and customary signs and fixtures either in the interior of the Premises or on the exterior of the Premises. Such signs shall be placed by Tenant as may be needed in the normal course of operation of the activities of Tenant and shall be removed as soon as possible after the need for such signs has expired.

ARTICLE XII **DAMAGE TO PREMISES**

12.01 *Abatement or Adjustment of Rent.* If the whole or any part of the Premises shall be damaged or destroyed by fire or other casualty after the execution of this Lease and before the termination hereof, Landlord may terminate this Lease effective the date of such casualty. The Landlord shall make its election within thirty (30) days after the occurrence of the casualty. If the Landlord does not terminate this Lease, then in every case the rent reserved in Article III herein and other

charges, if any, shall be abated or adjusted, as the case may be, in proportion to that portion of the Premises of which Tenant shall be deprived on account of such damage or destruction and the work of repair, restoration, rebuilding, or replacement or any combination thereof, of the improvements so damaged or destroyed, shall in no way be construed by any person to effect any reduction of sums or proceeds payable under any rent insurance policy.

12.02 Repairs and Restoration. Provided Landlord has not terminated this Lease as provided in Section 12.01, Landlord agrees that in the event of the damage or destruction of the Premises, Landlord forthwith shall proceed to repair, restore, replace or rebuild the Premises (excluding Tenant's leasehold improvements), to substantially the condition in which the same were immediately prior to such damage or destruction. The Landlord thereafter shall diligently prosecute said work to completion without delay or interruption except for events beyond the reasonable control of Landlord. Notwithstanding the foregoing, if Landlord does not either obtain a building permit within ninety (90) days of the date of such damage or destruction, or complete such repairs, rebuilding or restoration within nine (9) months of such damage or destruction, then Tenant may at any time thereafter cancel and terminate this Lease by sending ninety (90) days written notice thereof to Landlord, or, in the alternative, Tenant may, during said ninety (90) day period, apply for the same and Landlord shall cooperate with Tenant in Tenant's application. Notwithstanding the foregoing, if the amount of such damage or destruction occurs during the last three (3) months of the term of this Lease and the amount of damages is at least fifty percent (50%) or more of the replacement cost, (exclusive of the land and foundations), this Lease, except as hereinafter provided in Section 3 of Article XIV, may be terminated at the election of either Landlord or Tenant, provided that notice of such election shall be sent by the party so electing to the other within thirty (30) days after the occurrence of such damage or destruction. Upon termination, as aforesaid, by either party hereto, this Lease and the term thereof shall cease and come to an end, any unearned rent or other charges paid in advance by Tenant shall be refunded to Tenant, and the parties shall be released hereunder, each to the other, from all liability and obligations hereunder thereafter arising.

ARTICLE XIII CONDEMNATION

13.01 Total Taking. If, after the execution of this Lease and prior to the expiration of the term hereof, the whole of the Premises shall be taken under power of eminent domain by any public or private authority, or conveyed by Landlord to said authority in lieu of such taking, then this Lease and the term hereof shall cease and terminate as of the date when possession of the Premises shall be taken by the taking authority and any unearned rent or other charges, if any, paid in advance, shall be refunded to Tenant.

13.02 Partial Taking. If, after the execution of this Lease and prior to the expiration of the term hereof, any public or private authority shall, under the power of eminent domain, take, or Landlord shall convey to said authority in lieu of such taking, property which results in a reduction by ten percent (10%) or more of the area in the Premises, or of a portion of the Premises that substantially interrupts or substantially obstructs the conducting of business on the Premises; then Tenant or Landlord may, at its election, terminate this Lease by giving the other notice of the exercise of its election within thirty (30) days after receipt of notice of such taking. In the event of termination under the provisions of this Section, this Lease and the term hereof shall cease and terminate as of the date when possession shall be taken by the appropriate authority of that portion of the entire property that results in one of the above takings, and any unearned rent or other charges, if any, paid in advance by Tenant shall be refunded to Tenant.

13.03 Restoration. Provided the Landlord or Tenant shall not have terminated this Lease or in the event of a taking in respect of which Tenant shall not have the right to elect to terminate this Lease, this Lease and the term thereof shall continue in full force and effect and Landlord , at Landlord's sole cost and expense, forthwith shall restore the remaining portions of the Premises, including any and all improvements made theretofore to an architectural whole in substantially the same condition that the same were in prior to such taking. A just proportion of the rent reserved herein and any other charges payable by Tenant hereunder, according to the nature and extent of the injury to the Premises and to Tenant's business, shall be suspended or abated until the completion of such restoration and thereafter the rent and any other charges shall be reduced in proportion to the square footage of the Premises remaining after such taking.

13.04 Condemnation Awards. All compensation awarded for any taking, whether for the whole or a portion of the Premises, shall be the sole property of the Landlord whether such compensation shall be awarded for diminution in the value of, or loss of, the leasehold or for diminution in the value of, or loss of, the fee in the Premises, or otherwise. The Tenant hereby assigns to Landlord all of Tenant's right and title to and interest in any and all such compensation. However, the Landlord shall not be entitled to and Tenant shall have the sole right to make its independent claim for and retain any portion of any award made by the appropriating authority directly to Tenant for loss of business, or damage to or depreciation of, and cost of removal of fixtures, personalty and improvements installed in the Premises by, or at the expense of Tenant, and to any other award made by the appropriating authority directly to Tenant.

13.05 Release. In the event of any termination of this Lease as the result of the provisions of this Article XIII, the parties, effective as of such termination, shall be released, each to the other, from all liability and obligations thereafter arising under this lease.

ARTICLE XIV **DEFAULT**

14.01 Default. The following events shall constitute a default under this Lease and shall give rise to the remedies set forth herein:

- (a) Tenant shall be in default in the payment of rent or other charges herein required to be paid by Tenant; (default herein being defined as payment received by Landlord five (5) or more days subsequent to the due date); or
- (b) Either party has caused a lien to be filed against the other party's property and said lien is not removed within Sixty (60) days of recordation thereof; or,
- (c) Either party shall be in default of the observance or performance of any of the covenants and agreements required to be performed and observed by such party hereunder, if, such default continues for a period of thirty (30) days after written notice of such default is sent to the defaulting party, (or if such default shall reasonably take more than thirty (30) days to cure, the defaulting party has not commenced to actively cure the default within the thirty (30) days and diligently prosecuted the same to completion); or
- (d) Sixty (60) days have elapsed after the commencement of any proceeding by or against either party, whether by the filing of a petition or otherwise, seeking any reorganization, arrangement, composition, readjustment, liquidation, dissolution or similar relief under the

present or future Federal Bankruptcy Act or any other present or future applicable federal, state or other statute or law, whereby such proceeding shall not have been dismissed; or

- (e) Tenant is declared insolvent or adjudged bankrupt, or makes a general assignment for the benefit of its creditors.
- (f) Any of the staff of Edge Learning, Inc. dba The Edge Academy, whether teaching or non-teaching, join or become a member of an organized labor union or entity.

14.02 Remedies:

- (a) Termination of this Lease by the defaulting party by giving written notice of termination as provided in Section 18.02, in which event this Lease shall expire and terminate on the date specified in such notice of termination, with the same force and effect as though the date so specified were the date herein originally fixed as the termination date of the term of this Lease. All rights of Tenant under this Lease and in and to the Premises shall expire and terminate, and Tenant shall remain liable for all obligations under this Lease arising up to the date of such termination, and Tenant shall surrender the Premises to Landlord on the date specified in such notice; or
- (b) In the event of a default by Tenant, without terminating this Lease, and with or without notice to Tenant, Landlord may enter into and upon and take possession of the Premises or any part thereof, and Tenant must continue to pay rent under the terms of this Lease, and, at Landlord's option, remove persons and property therefrom, and such property, if any, may be removed and stored in a warehouse or elsewhere at the cost of, and for the account of Tenant, all without being deemed guilty of trespass or becoming liable for any loss or damage which may be occasioned thereby, and Landlord may rent the Premises or any portion thereof with or without advertisement, and by private negotiations and for any term upon such terms and conditions as Landlord may deem necessary or desirable in order to relet the Premises. Landlord shall in no way be responsible or liable for any rental concessions or any failure to rent the Premises or any part thereof, or for any failure to collect any rent due upon such reletting. Upon such reletting, all rentals received by Landlord from such reletting shall be applied: first, to the payment of any indebtedness (other than any rent due hereunder) from Tenant to Landlord; second, to the payment of rent and other charges then due and unpaid hereunder; third, to the payment of any costs and expenses of such reletting, including, without limitation, brokerage fees and attorney's fees and costs of alterations and repairs; and, the residue, if any shall be held by Landlord to the extent of and for application in payment of future rent as the same may become due and payable hereunder. In reletting the Premises as aforesaid, Landlord may grant rent concessions and Tenant shall not be credited therefor. If such rentals received from such reletting shall at any time or from time to time be less than sufficient to pay to Landlord the entire sums then due from Tenant hereunder, Tenant shall pay any such deficiency to Landlord. Such deficiency shall, at Landlord's option, be calculated and paid monthly. No such reletting shall be construed as an election by Landlord to terminate this Lease unless a written notice of such election has been given to Tenant by Landlord. Notwithstanding any such reletting without termination, Landlord may at any time thereafter elect to terminate this Lease for any such previous default provided same has not been cured; or

- (c) In the event of a default by Tenant, the Landlord without liability to Tenant or any other party and without constituting a constructive or actual eviction, suspend or discontinue furnishing or rendering to Tenant any property, material, labor, utilities or other service, whether Landlord is obligated to furnish or render the same, so long as Tenant is in default under this Lease; or
- (d) The pursuit of any remedy or remedies, including without limitation, any one or more of the remedies stated herein shall not (1) constitute an election of remedies or preclude pursuit of any other remedy or remedies provided in this Lease or any other remedy or remedies provided by law or in equity, separately or concurrently or in any combination, or (2) serve as the basis for any claim of constructive eviction, or allow Tenant to withhold any payments under this Lease.

14.02 Cure of Default by LANDLORD. If the Tenant defaults in the performance or observance of any agreement or condition in this Lease and does not cure such default within thirty (30) days after written notice from Landlord specifying the default (or if such default shall reasonably take more than thirty (30) days to cure, begins such cure within Thirty (30) days and diligently prosecutes the same to completion), Landlord may, at its option, without waiving any claim for damages for breach of agreement, at any time thereafter cure such default for the account of Tenant. Any amount paid or contractual liability incurred by Landlord in so doing shall be deemed paid or incurred for the account of Tenant and Tenant agrees to reimburse Landlord therefor and save Landlord harmless therefrom. Provided, however, that Landlord may cure any such default as aforesaid prior to the expiration of said waiting period, without notice to Tenant if any emergency situation exists, or after notice to Tenant, if the curing of such default prior to the expiration of said waiting period is reasonably necessary to protect the Premises or Landlord's interest therein, or to prevent injury or damage to persons or property. If Tenant shall fail to reimburse Landlord upon demand for any amount paid for the account of Tenant hereunder, said amount shall be added to and become due as a part of the next payment of rent due and shall for all purposes be deemed and treated as rent hereunder.

14.03 Cure of Default by Tenant If Landlord defaults in the performance or observance of any agreement or condition in this Lease contained on its part to be performed or observed, and if Landlord does not cure such default within thirty (30) days after written notice from Tenant specifying the default (or, if such default shall reasonably take more than thirty (30) days to cure, and Landlord shall not have commenced the same within the thirty (30) days and diligently prosecuted the same to completion), Tenant may, at its option, without waiving any claim for damages for breach of agreement, at any time thereafter cure such default for the account of Landlord and any amount paid or any contractual liability incurred by Tenant in so doing shall be deemed paid or incurred for the account of Landlord. Landlord shall reimburse Tenant therefor and save Tenant harmless therefrom; provided, however, that Tenant may cure any such default as aforesaid prior to the expiration of said waiting period, without notice to Landlord if an emergency situation exists, or after notice to Landlord, if the curing of such default prior to the expiration of said waiting period is reasonably necessary to protect the Premises or Tenant's interest therein or to prevent injury or damage to persons or property. If Landlord shall fail to reimburse Tenant upon demand for any amount paid or liability incurred for the account of Landlord hereunder, said amount or liability may be deducted by Tenant from the next or any succeeding payments of rent due hereunder; provided, however, that should said amount or the liability therefor be disputed by Landlord, Landlord may contest its liability or the amount thereof, through arbitration or through a declaratory judgment action and Landlord shall bear the cost of

the filing fees therefore.

14.04 ***TENANT'S Right to cure LANDLORD'S Default.*** In the event that Landlord shall fail, refuse or neglect to pay any mortgages, liens or encumbrances, the judicial sale of which might affect the interest of Tenant hereunder, or shall fail, refuse or neglect to pay any interest due or payable on any such mortgage, lien or encumbrance, Tenant may pay said mortgages, liens or encumbrances, or interest or perform said conditions and charge to Landlord the amount so paid and withhold and deduct from any rents herein reserved such amounts so paid, and any excess over and above the amounts of said rents shall be paid by Landlord to Tenant.

ARTICLE XV
TITLE

15.01 ***Subordination.*** Tenant shall, upon the request of Landlord in writing, subordinate this Lease to the lien of any present or future institutional mortgage upon the Premises irrespective of the time of execution or the time of recording of any such mortgage. Provided, however, that as a condition to such subordination, the holder of any such mortgage shall enter first into a written agreement with Tenant in form suitable for recording to the effect that:

- (a) In the event of foreclosure or other action taken under the mortgage by the holder thereof, this Lease and the rights of Tenant hereunder shall not be disturbed but shall continue in full force and effect so long as Tenant shall not be in default hereunder, and
- (b) Such holder shall permit insurance proceeds and condemnation proceeds to be used for any restoration and repair required by the provisions of Articles XII, XIII or XIV, respectively. Tenant agrees that if the mortgagee or any person claiming under the mortgage shall succeed to the interest of Landlord in this Lease, Tenant will recognize said mortgagee or person as its Landlord under the terms of this Lease, provided that said mortgagee or person for the period during which said mortgagee or person respectively shall be in possession of the Premises and thereafter their respective successors in interest shall assume all of the obligations of Landlord hereunder. The word "mortgage", as used herein includes mortgages, deeds of trust or other similar instruments, and modifications, and extensions thereof. The term "institutional mortgage" as used in this Article XV means a mortgage securing a loan from a bank (commercial or savings) or trust company, insurance company or pension trust or any other lender institutional in nature and constituting a lien upon the Premises.

15.02 ***Quiet Enjoyment.*** Landlord covenants and agrees that upon Tenant paying the rent and observing and performing all of the terms, covenants and conditions on Tenant's part to be observed and performed hereunder, that Tenant may peaceably and quietly have, hold, occupy and enjoy the Premises in accordance with the terms of this Lease without hindrance or molestation from Landlord or any persons lawfully claiming through Landlord

15.03 ***Good Title.*** Landlord warrants and represents, upon which warranty and representation Tenant has relied in the execution of this Lease, that Landlord is the owner of the Premises, in fee simple absolute, free and clear of all encumbrances, except for the easements, covenants and restrictions of record as of the date of this Lease. Such exceptions shall not impede or interfere with the quiet use and enjoyment of the Premises by Tenant. Landlord further warrants and covenants that this Lease is and shall be a first lien on the Premises, subject only to any Mortgage to which this Lease is subordinate or may become subordinate pursuant to an

agreement executed by Tenant, and to such encumbrances as shall be caused by the acts or omissions of Tenant; that Landlord has full right and lawful authority to execute this Lease for the term, in the manner, and upon the conditions and provisions herein contained.

15.04 *Licenses.* It shall be the Tenant's responsibility to obtain any and all necessary licenses and the Landlord shall bear no responsibility therefor; the Tenant shall promptly notify Landlord of the fact that it has obtained the necessary licenses in order to prevent any delay to Landlord in commencing construction of the Premises.

ARTICLE XVI **EXTENSIONS/WAIVERS/DISPUTES**

16.01 *Hold Over.* In the event that Tenant or anyone claiming under Tenant shall continue occupancy of the Premises after the expiration of the term of this Lease without any agreement in writing between Landlord and Tenant with respect thereto, such occupancy shall not be deemed to extend or renew the term of the Lease, but such occupancy shall continue as a tenancy at will, from month to month, upon the covenants, provisions and conditions herein contained at the rate as set forth in this agreement; provided that, if the Landlord has demanded the surrender of the Premises by Tenant in writing any the rate of rent for any holdover beginning with the next immediately following month shall be at a rate of One Hundred Fifty Percent, (150%) of the rate set forth herein.

16.02 *Waivers.* Failure of either party to complain of any act or omission on the part of the other party, no matter how long the same may continue, shall not be deemed to be a waiver by said party of any of its rights hereunder. No waiver by either party at any time, express or implied, of any breach of any provision of this Lease shall be deemed a waiver of a breach of any other provision of this Lease or a consent to any subsequent breach of the same or any other provision. If any action by either party shall require the consent or approval of the other party, the other party's consent to or approval of such action on any one occasion shall not be deemed a consent to or approval of said action on any subsequent occasion or a consent to or approval of any other action on the same or any subsequent occasion. Any and all rights and remedies which either party may have under this Lease or by operation of law, either at law or in equity, upon any breach, shall be distinct, separate and cumulative and shall not be deemed inconsistent with each other, and no one of them, whether exercised by said party or not, shall be deemed to be an exclusion of any other; and any two or more or all of such rights and remedies may be exercised at the same time.

16.03 *Disputes.* It is agreed that, if at any time a dispute shall arise as to any amount or sum of money to be paid by one party to the other under the provisions hereof, the party against whom the obligation to pay the money is asserted shall have the right to make payment "under protest" and such payment shall not be regarded as a voluntary payment and there shall survive the right on the part of the said party to institute suit for the recovery of such sum. If it shall be adjudged that there was no legal obligation on the part of said party to pay such sum or any part thereof, said party shall be entitled to recover such sum or so much thereof as it was not legally required to pay under the provisions of this Lease. If at any time a dispute shall arise between the parties hereto as to any work to be performed by either of them under the provisions hereof, the party against whom the obligation to perform the work is asserted may perform such work and pay the costs thereof "under protest" and the performance of such work shall in no event be regarded as a voluntary performance and shall survive the right on the part of the said party to institute suit for the recovery of the costs of such work if it shall be adjudged that there was no legal obligation on

the part of the said party to perform the same or any part thereof, said party shall be entitled to recover the costs of such work or the cost of so much thereof as said party was not legally required to perform under the provisions of this Lease and the amount so paid by Tenant may be withheld or deducted by Tenant from any rents herein reserved.

16.04 **Notices.** All notices and other communications authorized or required hereunder shall be in writing and shall be given by personal delivery or mailing the same by certified mail, return receipt requested, postage prepaid, and any such notice or other communication shall be deemed to have been given when received by the party to whom such notice or other communication shall be addressed. If intended for Landlord the same will be mailed to the address herein above set forth or such other address as Landlord may hereafter designate by notice to Tenant, and if intended for Tenant, the same shall be mailed to Tenant at the address herein above set forth, or such other address or addresses as Tenant may hereafter designate by notice to Landlord.

ARTICLE XVII **PROPERTY DAMAGE**

17.01 **Loss and Damage.** Notwithstanding any contrary provisions of this Lease, Landlord shall not be responsible for any loss of or damage to property of Tenant or of others located on the Premises, except where caused by the willful act or omission of Landlord, or Landlord's agents, employees or contractors, provided, however, that if Tenant shall notify Landlord in writing of repairs which are the responsibility of Landlord under Article VII hereof, and Landlord shall fail to commence and diligently prosecute to completion said repairs promptly after such notice, and if after the giving of such notice and the occurrence of such failure, loss of or damage to Tenant's property shall result from the condition as to which Landlord has been notified, Landlord shall indemnify and hold harmless Tenant from any loss, cost or expense arising therefrom.

17.02 **Force Majeure.** In the event that Landlord or Tenant shall be delayed or hindered in or prevented from the performance of any act other than Tenant's obligation to make payments of rent, additional rent, and other charges required hereunder, by reason of strikes, lockouts, unavailability of materials, failure of power, restrictive governmental laws or regulations, riots, insurrections, the act, failure to act, or default of the other party, war or other reason beyond its control, then performance of such act shall be excused for the period of the delay and the period for the performance of such act shall be extended for a period equivalent to the period of such delay.

ARTICLE XVIII **TERMINATION OF LEASE**

18.01 **Termination by Mutual Consent.** Upon the mutual agreement by the parties hereto, this Lease shall terminate at such time and upon such terms as the parties set forth in writing and which is executed by both parties as "evidence" of their mutual agreement.

18.02 **Termination Upon Default by Tenant or Landlord** In the event of a default by Tenant, pursuant to Article XIV, the Landlord may elect to terminate the lease as provided for in Article XIV by providing written notice at least five (5) days prior to the date of termination. In the event of default by Landlord, Tenant may elect to terminate the lease as provided for in Article XIV by providing written notice at least five (5) days prior to the date of termination.

18.03 **No Termination Upon Failure to Finalize Contract** The Parties hereto agree that the operation

of a community school by Edge Learning, Inc., is not, a condition which will cause a termination of this Lease. Accordingly, this Lease shall not terminate in the event that Edge Learning, Inc., does not finalize or renew, (as the case may be), the contract by and between Edge Learning, Inc. and the Sponsor and/or The Ohio Department of Education for the operation of a community school by Edge Learning, Inc., nor in any case where Edge Learning Inc., ceases the operation of a community school. In such case this Lease shall remain in full force and effect.

ARTICLE XIX MISCELLANEOUS

- 19.01 *Assignment and Subletting.*** Under the terms and conditions hereunder, Tenant shall not have the right to transfer and assign this lease or to sublet all or any portion of the Premises, without the prior written consent of Landlord. Landlord may sell, exchange, transfer, assign or hypothecate this Lease at any time without Tenant's consent; provided that such sale, exchange, transfer, assignment or hypothecation shall be made with respect to the entire Lease.
- 19.02 *Fixtures.*** All personal property, furnishings and equipment presently and all other trade fixtures installed in or hereafter by or at the expense of Tenant and all additions and/or improvements, exclusive of structural, mechanical, electrical, and plumbing, affixed to the Premises and used in the operation of the Tenant's business made to, in or on the Premises by and at the expense of Tenant and susceptible of being removed from the Premises without damage, unless such damage be repaired by Tenant, shall remain the property of Tenant and Tenant upon the request of Landlord shall be obligated to, remove the same or any part thereof at any time or times during the term hereof, provided that Tenant, at its sole cost and expense, shall make any repairs occasioned by such removal.
- 19.03 *Estoppel Certificates.*** At any time and from time to time, Landlord and Tenant each agree, upon request in writing from the other, to execute, acknowledge and deliver to the other or to any person designated by the other a statement in writing certifying that the Lease is unmodified and is in full force and effect, or if there have been modifications, that the same is in full force and effect as modified (stating the modifications), that the other party is not in default in the performance of its covenants hereunder, or if there have been such defaults, specifying the same, and the dates to which the rent and other charges have been paid.
- 19.04 *Invalidity of Particular Provision.*** If any term or provision of this Lease or the application hereof to any person or circumstance shall, to any extent, be held invalid or unenforceable, the remainder of this Lease, or the application of such term or provision to persons or circumstances other than those as to which it is held invalid or unenforceable, shall not be affected thereby, and each term and provision of this Lease shall be valid and be enforced to the fullest extent permitted by law.
- 19.05 *Captions and Definitions of Parties.*** The captions of the Sections of this Lease are for convenience only and are not a part of this Lease and do not in any way limit or amplify the terms and provisions of this Lease. The word "Landlord" and the pronouns referring thereto, shall mean, where the context so admits or requires, the persons, firm or corporation named herein as Landlord or the mortgagee in possession at any time, of the land and building comprising the Premises. If there is more than one Landlord or Tenant, the covenants of Landlord or Tenant shall be the joint and several obligations of each of them, and if Landlord or Tenant is a partnership, the covenants of Landlord shall be the joint and several obligations of each of the

partners and the obligations of the firm. Any pronoun shall be read in the singular or plural and in such gender as the context may require. Except as in this Lease otherwise provided, the terms and provisions of this Lease shall be binding upon and inure to the benefit of the parties hereto and their respective successors and assigns.

Nothing contained herein shall be deemed or construed by the parties hereto nor by any third party as creating the relationship of principal and agent or of partnership or of a joint venture between the parties hereto, it being understood and agreed that neither any provision contained herein, nor any acts of the parties hereto, shall be deemed to create any relationship between the parties hereto other than the relationship of Landlord and Tenant.

19.06 Brokerage. No party has acted as, by or through a broker in the effectuation of this Agreement, except as set out hereinafter.

19.07 Surrender Upon the expiration or earlier termination of this Lease, Tenant shall surrender to Landlord the Premises in good condition and repair, ordinary wear and tear excepted.

19.08 Entire Agreement. This instrument contains the entire and only agreement between the parties, and no oral statements or representations or prior written matter not contained in this instrument shall have any force and effect. This Lease shall not be modified in any way except by a writing executed by both parties.

19.09 Governing Law. All matters pertaining to this agreement (including its interpretation, application, validity, performance and breach) in whatever jurisdiction action may be brought, shall be governed by, construed and enforced in accordance with the laws of the State of Ohio.

19.10 Liability of LANDLORD. Notwithstanding anything to the contrary in this Lease, if Landlord fails to perform any of its obligations under this Lease, and, as a consequence of this default, Tenant recovers a money judgment against Landlord, that judgment shall be first satisfied from the general assets of the Landlord.

IN WITNESS WHEREOF, the undersigned have executed this Lease Agreement as of the date set forth on page 1.

CHARTER DEVELOPMENT
FOUNDATION, INC.

By:  _____

Its: TRUSTEE

Witness  _____

The Edge Academy

By:  _____

Its: Board President

Witness  _____

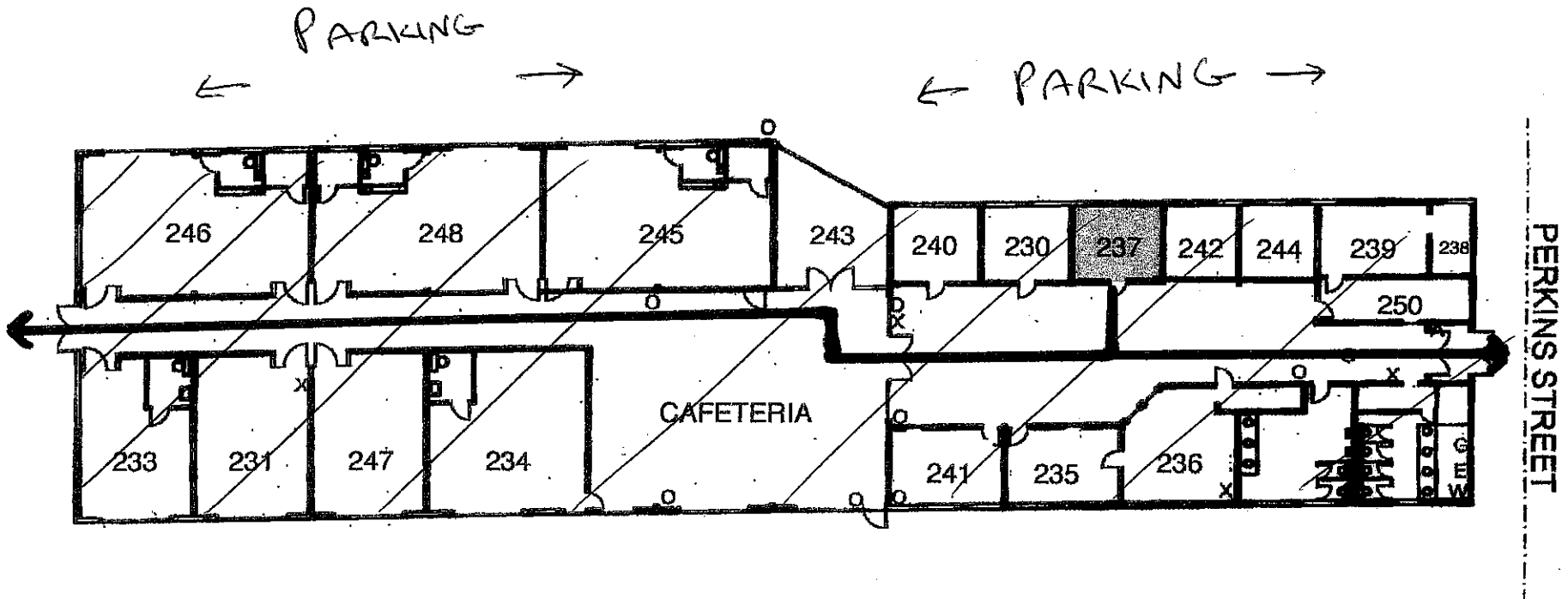

The Edge Academy Annex

Exhibit A

280 Perkins Street

Akron, Ohio 44304

IRN #133538

EMERGENCY MAINTENANCE # 234-205-7166

LEGEND

- O - CAMERA
- G - GAS SHUT OFF
- W - WATER SHUT OFF
- E - ELECTRICAL SHUT OF
- X - FIRE EXTINGUISHER
- A - ALARM PANEL
- D - AED

School Name:	The Edge Academy	Date:	2/7/2020
--------------	------------------	-------	----------

6.3a Mission, Vision, Philosophy

The mission should answer the question *why do we exist?* The vision should answer the question *what do we hope to become?* Likewise, a school's philosophy should answer the question *what do we value and believe about educating students?*

Mission	6.3a	1) MISSION (Why do we exist?): State the school's clear, <i>concise</i>, and compelling mission statement that describes its specific intent/purpose.
---------	------	--

The mission of The Edge Academy is to become one of the highest performing community schools by creating a climate and culture which facilitates ongoing learning and success inside and outside of the classroom.

We believe that a standards-based curriculum focused on a plethora of learning experiences, enriched with technology, in a collaborative and nurturing environment. We believe in providing students with a purpose for learning will be able to build a more significant base of background knowledge. This, in turn, will enable our students to be truly successful in their academics.

We believe that these methods are appropriate for all students, including students with disabilities, English language learners and low performing students.

Vision	6.3a	2) VISION (What we hope to become?): State the school's clear, <i>concise</i>, and compelling vision statement that describes the anticipated operation, function and success of the school over time.
--------	------	---

The Edge Academy strives to provide competent and compassionate education to the students and families of Akron to prepare them to be well rounded leaders within the community.

Shared Vision and Mission: A fundamental characteristic of the professional learning community's vision is its unwavering focus on student learning. The shared values and vision among the school staff guide decisions about teaching and student learning, and support norms of behavior. These values are embedded in the day-to-day actions of The Edge Academy as the learning community engages and develops the commitment and talents of all individuals in a group effort that pushes for learning of high intellectual quality. We will do this by supporting

the implementator of Ohio's Learning Standards. Students will be provided quality instruction by the staff.

Philosophy	6.3a	<p>3) PHILOSOPHY (What do we value and believe about educating students?)</p> <p>State the school's clear, <i>concise</i>, and compelling philosophy that describes the values and beliefs by which the school will operate.</p>
------------	------	---

We believe that all children can learn and make educational growth. This will be done by providing superior academic learning opportunities. We believe in teacher directed, result oriented curriculum for reading, math, writing, science and social studies. All curriculums are aligned to Ohio's Learning Standards. We provide a safe, loving, disciplined and caring school environment.

6.3b Curriculum

The primary function of a school is to provide for the education of students. The curriculum describes all planned learning of students and should describe the learning experiences through which a student will progress. Responses should address the following questions: *What are the learning goals for students at your school and what research support the curriculum choice and its effectiveness for the student population served?* Each of the items below should be addressed with strong evidence and detail.

Curriculum – Learning Standards	6.3b	<p>1) Provide specific standards with detailed descriptions for all core and non-core content (physical education, music, art, technology, etc.), including social-emotional learning, addressed by school that will enable each student to acquire learning across all four learning domains: foundational knowledge and skills, well-rounded content, leadership & reasoning, and social-emotional learning.</p> <p>If the school will use Ohio’s Learning Standards in all core and non-core content areas, please check the box. <input checked="" type="checkbox"/></p>
<p>The school uses Ohio’s Learning Standards (http://education.ohio.gov/Topics/Learning-in-Ohio/OLS-Graphic-Sections/Learning-Standards) in all of its core subject areas of math, language arts, science and social studies and non-core subject areas of music, technology, art, physical education, and Spanish (standards listed under world language). http://education.ohio.gov/getattachment/Topics/Ohios-Learning-Standards/Physical-Education/Updated-Physical-Education-Standards-Evaluations-2/Updated-Physical-Education-Standards.pdf.aspx</p> <p>This is a link to the PE standards, benchmarks, and indicators that Ohio adopted for the 2016 school year. Those are the ones the school uses.</p> <p>The Edge Academy is a Leader in Me school. To meet the SEL standards that Ohio has set for this year the school we follow the character development curriculum that Leader in Me set. We also have a DEAL (drop everything and lead) 20 minutes block at the end of every day.</p>		
Curriculum - Model	6.3b	<p>2) Does the school plan to use the Ohio Model Curriculum?</p> <p><input checked="" type="checkbox"/> Yes, the school will utilize the Ohio Model Curriculum in all core and non-core content areas.</p> <p><input type="checkbox"/> No, the school will utilize the curriculum model described below.</p> <p>If “no” is marked, provide evidence of the school’s written curriculum including standards, assessments, differentiation strategies, etc. as an attachment (Attachment # _ Curriculum Model). Describe the research supporting the model.</p>
Curriculum - Pacing Guides	6.3b	<p>3) Provide a detailed description of the development process for pacing guides used in your school that includes the deconstruction of standards.</p>

Action Step 1: Identify and communicate the content considered essential for all students versus that considered supplemental or necessary only for those seeking postsecondary education.

In our schools August training all teachers will meet in Teacher-Based-Teams to discuss specifics for targets and goals of our students learning. This will be done in August to ensure that any changes are made based on new staff, needs of students, OIP goals, and feedback from the previous school year.

Action Step 2: Ensure that the essential content can be addressed in the amount of time available for instruction.

During these meetings teachers will create their maps and pacing guides for each class taught or each grade level they teach including all non-core subjects. This is reviewed by content area groups and grade level groups to make sure the correct content and standards are being reviewed using data.

Teachers will work

specifically on deconstructing all learning standards to ensure that the teachers thoroughly understand what each standard explicitly and implicitly indicates. What is it that students must know and be able to do as stated in each of these learning outcomes?

Action Step 3: Sequence and organize the essential content in such a way that students have ample opportunity to learn it.

Teachers will need to make sure that that have all the following information:

1. All content standards to be covered that month; 2. Target Standards for that month; 3. Units of Study/Curriculum utilized for that month (i.e. sections of the textbook, novels, web resources, independent student programs, etc.); 4. Any further resources they'll need for that month (i.e. manipulatives, Nooks, Chromebooks, etc.)

If curriculum maps

already exist, they will review them to ensure that any time adjustments necessary to incorporate new or different standards are made, and the maps are updated.

Action Step 4: Ensure that teachers address the essential content.

During the school year teachers are provided time for both horizontal and vertical grade level teams to meet to discuss the chunking standards and targets, considering instructional materials and resources available/needed to address the targets effectively.

Identify the instructional and assessment resources that are currently in hand that align well to the new curriculum; identify those that do not.

Begin to identify additional professional learning opportunities teachers will need to effectively deliver the new/revised curriculum.

Action Step 5: Protect the instructional time that is available

Consider any policies or procedures that should be established to protect classrooms from unnecessary interruptions.

Consider scheduling so that teachers have regular opportunities to plan and reflect on their practice together.

**Curriculum – Lesson
Template**
6.3b
4) Explain what specific components are to be included in model lesson plan templates and rationale.

Teachers will turn in lesson plans weekly. The lesson plans will be reviewed by the teachers academic coach and the principal lesson plans will be reviewed by the academic coach/curriculum coordinator, and principal to ensure that effective teaching strategies are being implemented at all levels and that the curriculum is being followed with fidelity. Lesson plans must have the following items:

Teachers will turn in lesson plans weekly. The lesson plans will be reviewed by the teachers academic coach and the principal to ensure that effective teaching strategies are being implemented at all levels and that the curriculum is being followed with fidelity. Lesson plans must have the following items:

- Standards: What Ohio Learning Standard is being covered?
- Objectives: What are the deconstructed standards that students are expected to learn, written in kid-friendly language (I can statements)
-
- Materials: What will the teacher need to ensure that the lesson is successful and accommodating to all students?
- Procedures: Outline of the lesson—including specific research based instructional strategies incorporated throughout the lesson
- Assessment: How will the teacher assess the student learning for the lesson (observation, homework, tests, activities, formative and/or summative)
- Differentiation: How will the teacher meet the needs of all students, with specific attention to the 20% of students with the lowest level of learning?

The rationale behind the current lesson plan template: The current template requires teacher to set a specific goal for their teaching based on Ohio’s Learning Standards. It also requires staff to look at specific research-based strategies that will be incorporated throughout the lesson. The lesson plan also requires teachers to have an understanding of how they will differentiate within the lesson. The template is also directly linked to OTES requirements that teachers are required to meet during their formal evaluations.

“The rationale behind the current lesson plan template: The current template requires teachers to set a specific goal for their teaching based on Ohio’s Learning Standards. It also requires staff to look at specific evidence-based strategies that will be incorporated throughout the lesson.

The lesson plan will be altered based on data collected and reviewed. In TBT meetings the teachers will see what strategies are working and creating the most academic gains.”

The lesson plan also requires teachers to have an understanding of how they will differentiate within the lesson. The template is also directly linked to OTES requirements that teachers are required to meet during their formal evaluations.

Curriculum - Alignment with Ohio Learning Standards

6.3b

5) Provide evidence of alignment of the school’s curriculum model to the Ohio Learning Standards, the Ohio Strategic Plan for Education: 2019-2024, and the mission, vision, and philosophy of the school.

All lessons will be aligned to Ohio's Learning Standards as they are the foundation that developed all courses of study at the Edge Academy. This ensures that the written curriculum, classroom instruction, and assessments of learning all match an alignment that research suggests makes a powerful impact on student achievement. In all non-core classes the curriculum used is directly aligned to the Ohio State Standards which align with the Ohio Model curriculum that we are using. in music, physical education, visual arts, world language and technology. This

alignment is done by the teacher and curriculum coordinator through the construction, evaluation and revision of curriculum maps and pacing guides.

The model of curriculum is also aligned to the mission, vision, and philosophy of the school by providing superior academic instruction and developing world class citizens who make educational growth each year. The curriculum meets the academic needs of the students by ensuring they are learning all of Ohio’s Learning Standards and making growth towards grade level and above.

Students’ progress will be demonstrated on the data from the state mandated assessments and the nationally normed assessment (MAP). Other data from the Read Theory and Success Maker programs will support individual student progress. Additional assessments will provide data that will let teachers know if other resources are needed in order for students to achieve at a higher level.

Curriculum - Literacy Skills

6.3b

6) Describe how the school will develop literacy skills across all ages, grades and subjects, as well as building the capacity for effective literacy instruction (i.e. search ODE Ohio’s Plan to Raise Literacy Achievement Birth-12, January 2018).

All Elementary students incorporate Read Theory, Reading Street, and Success Maker into our reading improvement plan Our overall literacy

curriculum also includes other online subscriptions and which grade levels use them are attached. Between these three tools, our RIMPS, and other reading achievement plans we make sure that they all are aligning them with the Ohio State standards. Currently we are working on a Literacy grant to help move forward our ability and resources to provide exceptional literacy learning for our students. Our schools OIP and reading improvement plans has goals specifically focused on improving our students overall literacy ability.

Curriculum – Future Success

6.3b

7) Describe how the school will identify and support student's future success (i.e. focus on career, project-based learning, expanding work-based learning, career-tech/industry credentials, job shadowing and expanding pathways to graduation).

The Edge Academy has a sister Middle School very close in proximity that the majority of our students attend after finishing fifth grade at our building. Our teachers still see those students and collaborate with the Middle School teachers when or if necessary to help share successful strategies in dealing with academic or behavioral issues with certain students. At the Middle School some students go through a process to apply for specific High Schools or programs in the area. Our Elementary staff have helped with the process and written many letters of recommendation when appropriate. In the classroom students become familiar with careers through learning that connects classroom instruction to future work. Career awareness strategies show students various types of careers and stimulate interest in future work.

6.3c Instructional Delivery Methods and Resources/Materials

Instructional methods and resources are the ways and tools used to deliver the curriculum. *What strategies or techniques will be used to engage students in learning? What instructional resources and materials will the teachers and students be using, including technology? With strong evidence and great detail, each of the following items should be addressed.*

Instructional Delivery Methods

6.3c

1) Explain in detail the primary, evidence-based instructional delivery methods, strategies, and/or techniques (i.e. high yield instructional practices, project-based learning, computer-based, etc.) that will be used to provide daily instruction in your school to support success for all students.

The School will employ a variety of instructional methods to ensure that the individual educational needs of all students are met, to maintain student interest, and to challenge all students to strive for academic excellence. Teaching students skills in each curriculum area will be accomplished through the following instructional techniques:

- Formative Instructional Practices-Formative instructional practices including I can statements and strategic teacher questioning techniques

- Flexible skill based groups-Based on summative assessments and nationally-normed assessments students are placed into RTI groups based on their current ability and specific skills in which they are deficient. The students are then progress monitored to check for growth and understanding.
- Computer-based and/or assisted instruction- Throughout the classrooms at the Edge Academy the teachers use computer instruction in all core subjects as an additional instructional tool. It is mostly used when students are working in classroom stations as one of the activities they complete.
- Cooperative learning- Throughout the classrooms at The Edge Academy cooperative learning is used when students complete tasks as a small group. In the lower level classrooms it is often used to complete a simple problem or activity together. In the upper level classrooms students often work on classroom projects as a group.
- Field trips, guest speakers, community service and special presentations-Throughout the school year the students at The Edge Academy have the opportunity to attend field trips to local museums, science centers, and music halls. The field trip experience helps extend the learning in the science and social studies classrooms and the fine arts.
- Multi-media instruction-Within the daily instruction the teachers at The Edge Academy use a variety of multi-media tools including, reading and mathematics online systems directly linked to the current curriculum, overhead projectors, ELMOs, student computers, and other online programs to supplement the classroom instruction.
- The Edge Academy will primarily use Marzano’s nine instructional strategies for effective teaching and learning. Marzano’s nine instructional strategies for effective teaching and learning-Teachers at The Edge Academy use Marzano's instructional strategies such as identify similarities and differences, summarizing and note taking, reinforcing efforts, homework and practice, nonlinguistic representations, cooperative learning, setting objectives, generating and testing hypotheses, and using cues and questions. The nine different strategies are evidence based and teachers dissect which of these strategies work best for each student and differentiate appropriately.

<p>Instructional Delivery Methods - Blended Learning Instructional Model</p>	<p>6.3c</p>	<p>2) Is the school using a blended learning instructional model, as defined in section 3301.079 of the Revised Code? If yes, check box. <input type="checkbox"/></p> <p><u>Blended Learning Requirements - please provide ALL of the following:</u></p> <p>a. An indication of what blended learning model or models will be used;</p>
---	--------------------	--

		<ul style="list-style-type: none"> b. A description of how student instructional needs will be determined and documented; c. The method to be used for determining competency, granting credit, and promoting students to a higher grade level; d. The school's attendance requirements, including how the school will document participation in learning opportunities; e. A statement describing how student progress will be monitored; f. A statement describing how private student data will be protected; g. A description of the professional development activities that will be offered to teachers.
<p>At this time, The Edge Academy does not utilize a blended learning instructional model.</p>		
Instructional Delivery Methods – Research Base	6.3c	3) Provide the evidence-base for the primary delivery methods, strategies, and/or techniques including impact on population served. Refer to <u>ESSA</u> definition of evidence based strategies. Provide documentation from the: What Works Clearinghouse or Ohio's Evidence-Based Clearinghouse for meeting level I or II criteria.
<p>Formative Instructional Practices-research has shown that Formative instructional practices when implemented school wide will raise student achievement and overall success. I can statements and teacher questioning has been shown to increase student's achievement especially for students with disabilities. Benjamin S. Bloom "saw reducing gaps in achievement of various groups of students (low income and special education) as a simple problem of reducing variation in student learning outcomes" (Viegut D. 2006) <i>Formative instruction has been proven to research based and meets the definition for research based Per ESSA. The research shows that formative instructional practices have a moderate link for improving instructional for at risk and low income students.</i></p> <p>Cooperative learning- According to the study conducted by Durukah 2010 "cooperative learning has a positive effect on increasing reading performance specifically with special education students and low ses" This meets the ESSA requirement of being an level 3 study which has promising evidence from at least one well-designed and well-implemented correlational study.</p> <p>Flexible Skill based groups for intervention: research has shown that flexible grouping can increase student achievement when used with</p>		

frequent monitoring. According to ESSA, requires that students performance in subgroups be monitored frequently (ESSA 2016) According to The Study on Flexible Grouping by Velechko, 2016 " Most at risk learners benefit from flexible grouping." *This study meets the ESSA requirements of research base by being a experimental study and showing statistical impact on student performance. The research has shown promising evidence when used with at risk and low income students.*

Computer-based and/or assisted instruction-computer based instruction- engages students and has positive effects on achievement. According to the experiential study done by Kulik and Kulik "the effectiveness of CBI raise achievement of students with even more substantial increase of achievement with special education students." (1999) *This meets the ESSA requirement of being an experimental study which demonstrated a statically significant effect on improving student outcomes, including students who are at risk and low income.*

Cooperative learning- According to the study conducted by Durukah 2010 "cooperative learning has a positive effect on increasing reading performance specifically with special education students and low ses" *This meets the ESSA requirement of being a experimental study which demonstrated a positive effect on increasing student achievement, including students who are at risk and low income.*

Field trips, guest speakers, community service- According to a study conducted by Griffin 2004. "Some studies investigating the intrinsic value of field trips indicated that student groups who visited museums showed clear cognitive gain, compared with those who had not and that those classes that visited museums expressed more positive attitudes and motivation toward learning.

Marzano's nine instructional strategies for effective teaching and learning-Researchers at Mid-continent Research for Education and Learning (McREL) have identified nine instructional strategies that are most likely to improve student achievement across all content areas and across all grade levels. . Marzano researched each of these evidence based strategies and noticed that they created results across all grade levels. This research was also a quasi-experiment which would relate back to ESSA Level 2.

https://www.researchgate.net/profile/Robert_Marzano/publication/242760081_Meta-Analytic_Synthesis_of_Studies_Conducted_at_Marzano_Research_Laboratory_on_Instructional_Strategies/links/56f26c080aed354e57293b1/Meta-Analytic-Synthesis-of-Studies-Conducted-at-Marzano-Research-Laboratory-on-Instructional-Strategies.pdf

Since the McREL completed research including experimental studies on Marzano's instructional strategies it meets the requirements of ESSA. All nine strategies meet the requirements of ESSA : Identifying similarities and differences, summarizing and notetaking, reinforcing effort and providing feedback, homework and practice, and cooperative learning have all shown to have a strong/large impact on low income and at risk

Instructional Delivery Methods - Resources/Materials	6.3c	4. Identify resources and materials that will be in place at the school's opening in all core and non-core content areas, including technology.
---	-------------	--

The Edge Academy will provide the following items to staff:

My Math mathematics online subscription <https://s3.amazonaws.com/ecommerce-prod.mheducation.com/unitas/school/explore/sites/mymath/my-math-overview-brochure-2017.pdf> ,

- Reading Street reading online subscription
- Scholastic magazines for supplementation in science and social studies classroom
- Houghton Mifflin’s Science Fusion textbooks for all grade levels.
- Between one and three computers are in some classrooms based on the teachers wants or needs. Each hallway K/1, 2/3, and 4/5 have a mobile Chromebook lab that they use for small groups and for whole classroom use at least one to two times a week. Each Google Chromebook cart has a class set of Google Chromebooks (25).
- Reading library full of student appropriate leveled readers
- Hands-on manipulatives:
 Science – teachers will have access to lab kits aligned with the curriculum, microscopies, test tubes, magnifying glasses, etc.
 Math- flashcards, counting blocks, base ten blocks, tangrams, number lines, protractors, rulers, calculators, etc
 Reading-flashcards, cvc games, blending cards, literary dice, leveled readers, etc
 Social Studies- maps, globes, flashcards, etc
- 3rd-5th grade will follow the Gallopade Social Studies curriculum. The Ohio Standard aligned series Communities: Past & Present, Near & Far.
- ELMO
- Projector
- Online programs of ABC Teach, Scholastic Teachables, Super Teacher Worksheets, Flocabualry, IXL Reading, Sumdog Math, My Math, Glencoe Math, Study Island (Math only), TCI - Soc. Studies, Science Fusion, Raz Plus, Ed City, Fluency and Fitness, BrainPOP, Success

- Visual Arts: will have access to all art supplies needed based on what each grade level must covered in the standards. The teacher orders all supplies at the beginning of the year including by not limited to: crayons, markers, yarn, pencils, paper, glue, paint, brushes, clay, etc.
- Music: recorders, drums, sheet music, piano, music DVDs, and other instruments.
- Physical Education: basketball hoops, basketballs, soccer balls, scooters, foam bats and balls, golf supplies, footballs, tennis balls, dodgeballs, etc.

Resources used to support Ohio’s model curriculum:

Mathematics: McGraw-Hill’s MyMath is utilized at The Edge Academy and has been selected using the Mathematics Resource Materials Filter (<http://education.ohio.gov/getattachment/Topics/Learning-in-Ohio/Mathematics/Ohio-s-Learning-Standards-in-Mathematics/Mathematics-Resource-Filter.pdf.aspx>) provided by the Ohio Department of Education. Through mastery of these standards, students will develop a deep understanding of mathematical concepts. A standards alignment guide may be found here: <https://s3.amazonaws.com/ecommerce-prod.mheducation.com/unitas/school/explore/sites/mymath/ccss-alignment-guide.pdf>

English/Language Arts: Scott Foresman Reading Street is utilized at The Edge Academy and has been selected using Ohio Department of Education’s Research Supporting Key Elements of the Standards found in Appendix A (http://education.ohio.gov/getattachment/Topics/Learning-in-Ohio/English-Language-Art/English-Language-Arts-Standards/Appendix_A.pdf.aspx)

A standards alignment guide for each grade level may be found here:

<https://www.pearsonschool.com/index.cfm?locator=PS1dH9&PMDBSOLUTIONID=6724&PMDBSITEID=2781&PMDBCATEGORYID=3289&PMDBSUBSOLUTIONID=&PMDBSUBJECTAREAID=&PMDBSUBCATEGORYID=&&PMDbProgramID=69481&elementType=correlations&elementID=SeeAllNATL>

Science: Houghton Mifflin Harcourt Science Fusion is utilized at The Edge Academy and has been selected using Ohio’s Cognitive Demands for Science Table 1 in Ohio’s Learning Standards for Science. (<http://education.ohio.gov/getattachment/Topics/Ohios-Learning-Standards/Science/ScienceStandards.pdf.aspx>) Information about standards alignment can be found here: <https://www.hmhco.com/programs/sciencefusion/overview>

Social Studies: Gallopade Social Studies curriculum. The Ohio Standard aligned series “Communities: Past & Present, Near & Far.” is utilized at The Edge Academy and has been selected after using the Alignment Toolkits (Phase 1 and Phase 2) provided by the Ohio

Department of Education <http://education.ohio.gov/Topics/Learning-in-Ohio/Social-Studies/Transition-Tools-Ohio-Learning-Standards-K-1>

Any gaps that are found using the Alignment Toolkit Phase 1 will be filled through teacher-created resources and online resources that are acquired by the teacher as well as from the textbook provider.

Instructional Delivery Methods - Resources/Materials

6.3c

5. Explain the selection, approval (including board) and change process for instructional resources and materials to be used by teachers and students, including technology.

The Edge Academy will emphasize the instructional design of grade-level scope and sequence based on Ohio's Learning Standards. At the end of each school year a curriculum survey will be sent to all teachers, para-professionals, and administrators. The questions will cover what they are currently using in their classroom, what they think is working, what they think is not working and why. The survey results will then be reviewed by the principals, director, and curriculum coordinator to analyze and decide if there is a need for updated curriculum to better meet the needs of students at The Edge Academy and if they are meeting Ohio's Learning Standards. If based on the survey results and administrative data analysis there is a need for new and/or updated materials the following steps will be taken:

Teachers will follow the change process below for selecting new instructional resources:

- select the material that is wanted (software, websites, and/or books) this also includes all computer and technology hardware
- Submit the materials to the curriculum coordinator
- Academic coach will then research the materials to ensure that they are research based and appropriate for the student objectives and learning standards for the grade level and content of need. The materials selected will be from ODE approved vendors which are all aligned to state standards. TBT's are used to identify gaps in the current curriculum and complete a meeting sheet providing information. Any gaps that are found will be filled through teacher created resources, online resources, as well as resources provided by the vendor.

Curriculum coordinator will then send the research to the director who will bring all information to the board for final approval. The board will have the final approval for large orders and anything over \$3,000.

6.3d Continuous Improvement and Professional Growth

Schools must improve instructional practices and student performance on a continual basis. With strong evidence and great detail, each of the following items should be addressed.

Continuous Improvement

6.3d

1) **How will the school develop, monitor, and evaluate a school improvement plan using the Ohio 5-Step Decision Making Process. Describe the structures and processes to support the improvement planning.**

We are currently in the Ohio Improvement Process. The following processes are being implemented:

- Teacher Based Teams work weekly to review current implementation of curriculum and identify gaps in current curriculum and complete a meeting sheet providing information discussed (see attachment)
- Teacher Based Teams and Community School Leadership Team meet bi-monthly to review student data and make instructional decisions based on the most current data available.
-
- Teacher Based Teams and Curriculum Coordinator meet annually to review curriculum maps and current curriculum being implemented.
- Community School Leadership Team and the administrative team conduct informal evaluations to ensure that research-based instructional strategies are being implemented with fidelity.
- Surveys are given periodically to teachers to ensure continued effectiveness of the Continuous Improvement Plan
- Teachers will be given a yearly survey to complete. The survey will have the teachers review the curriculum, instructional strategies, resources, materials, and technology. The administrative team will then review the surveys to look at the areas of concern/need. The administrative team will then share out with staff changes that will be made to meet the needs and concerns of the staff.
- At the end of the year the staff will meet in an all staff meeting to discuss the effectiveness of the school's leadership structure. The administrative staff will then review comments from staff to make changes for the next year.
- The process will be documented in TBT and CSLT team agendas and notes. The Process will also be documented and shared out at the Board meetings throughout the school year.

The school will follow the steps above to ensure that the school is following the Ohio Improvement Process to ensure that all aspects of the five step process are being followed. The CSLT will meet every summer to review the school's improvement plan: the team will rewrite the SMART goals as needed and analyze end of year benchmark and state assessment data to decide if our goals were achieved, and if not what process (professional development, different instructional strategies, or instructional teams) needs to be added or taken away to ensure that the following year the goals set by the CSLT and reviewed by the staff weekly will be met. The TBTs will continue to link their data to the school improvement goals to ensure that all staff members are actively involved with the constant improvement of the school.

Ohio Teacher Evaluation System (OTES)	6.3d	<p>2) Confirm implementation of the Ohio Teacher Evaluation System (OTES) or an alternative aligned to Ohio Standards for Educators.</p> <p><input checked="" type="checkbox"/> Yes, the school will implement the Ohio Teacher Evaluation System. Please identify what credentialed individuals (job title) will be conducting the evaluations?</p> <p><input type="checkbox"/> The school will implement an alternative evaluation system as described below.</p> <p>3) If an alternative evaluation system is used, provide evidence of alignment to Ohio Standards for Educators and connection to accountability for student performance. What credentialed individuals (job title) will be conducting the evaluations?</p>
---------------------------------------	------	--

The OTES system was first implemented exclusively during the 2013-14 school year and has been utilized as the primary evaluation tool since that time. (Approved at the 5/12/14 board meeting)

The Dean of Students/Assistant Principal, principal and director will conduct the evaluations. The Superintendent/Director, Principal, and Special Education Coordinator are credentialed OTES evaluators. The Dean of Students is not an OTES evaluator. He does however evaluate paraprofessionals and aides who help out in the classroom. Our school evaluates everyone twice a year even if they are not OTES evaluated.

Ohio Principal Evaluation System (OPES)	6.3d	<p>4) Confirm implementation of Ohio Principal Evaluation System and Ohio Superintendent Evaluation System (if applicable) or alternative aligned to Ohio Standards for Principals and Ohio Standards for Superintendents.</p> <p><input checked="" type="checkbox"/> Yes, the school will implement the Ohio Principal Evaluation System and the Ohio Superintendent Evaluation System.</p> <p><input type="checkbox"/> The school will implement an alternative evaluation system as described below.</p> <p>5) If an alternative evaluation system is used, provide evidence of alignment to Ohio Standards for Principals and Ohio Standards for Superintendents and connection to accountability for student performance. What credentialed individuals (job title) will be conducting the evaluations?</p>
---	------	--

The Director will conduct the Principal Evaluation and a board-appointed representative (the founder of the school) will evaluate the director. The director is a credentialed evaluator for the OPES system.

Local Professional Development Committee	6.3d	6) Discuss development and implementation of Local Professional Development Committee, including bylaws, committee membership, roles and responsibilities, processes and procedures, Individual Professional Development Plan (IPDP) template, etc.
<p>The LPDC plan is currently being implemented in the school for all teachers. At The Edge Academy, the use of LPDC is used with all professionals that hold a license. Yearly a team is selected to be part of the LPDC committee and meet monthly to review status of teacher and professionals licenses and to sign off on instructional hours completed by staff members at the school. The LPDC follows the guidelines set forth by ODE http://education.ohio.gov/Topics/Teaching/Professional-Development/LPDC-s</p>		
Resident Educator Program	6.3d	7) Discuss implementation of Ohio’s Resident Educator Program in the school (i.e., mentoring process, meetings, monitoring of work completed, timelines, ratios of mentor to mentees, etc.).
<p>The resident educator system is currently being implemented throughout the school for all teachers who qualify under the resident educator license. http://education.ohio.gov/Topics/Teaching/Resident-Educator-Program</p> <p>All new teachers are assigned an Ohio State trained mentor that is onsite by August 1st.</p> <p>The RE program standards Planning tool in CORE will be completed.</p> <p>The Edge Academy will provide orientation to the RE Program for Resident Educators, mentors, and building leaders with the following requirement for supporting RE years 1-4</p> <p>Year 1: Assign 1 mentor to 3 or less REs; formative Progress Review (FDR) with mentor and Resident Educator</p> <p>Year 2: Determine mentor Model to use for Resident Educator: one to one, cohort co-teaching, or a combination; Complete Formative Progress Review (FDR) with mentor and RE.</p> <p>Year 3: Work with employer to determine if Resident Educators are ready to take RESA</p> <p>Year 4: Identify Resident Educators who need to begin RESA/Retake deficient portions of the RESA. Resident Educators who successfully passed RESA may engage in teacher leadership activities.</p> <p>Year- long support that all resident educator receive:</p>		

- Monthly all resident educator and mentor meetings
- Formal and informal observations by mentor

online tool to input all paperwork needed for each year in the resident educator program-monitored by mentor and the program coordinator

Professional Development Plan for Teachers	6.3d	8) Using the Ohio Standards for Professional Development (adopted 2015), describe the process for how the school will <i>develop, implement, and evaluate</i> a differentiated professional development plan for teachers informed by student data, curriculum needs, OTES, IPDPs, Resident Educator Program, etc. and how it will link to the school’s continuous improvement plan.
---	-------------	---

Each year a professional development plan will be created for the next school year. The administrative team will look at the following to decide what professional development will be needed:

- OIP goals- did we meet our goals? And if not what professional development would help the school achieve them?
- Curriculum- if a new program is purchased the administrative team will work with the vendor to provide appropriate professional development for the staff that will use the new program.
- IPDP- work with the LPDC team to decide what professional development is needed to meet teacher’s goals.
- Resident educator- work with the program coordinator to decide the needs of the resident educators and what professional development will be provided to the teachers in the program.
- Look at MAP assessments, AIR Assessments, TBT data, and classroom assessments to see where students are not meeting grade level expectations and provide professional development in those areas to help increase teacher knowledge and skills to help increase student performance.

Once the administrative team has gathered all the data they will work with vendors, outside professional development providers, and school staff to provide appropriate professional development throughout the school year.

Once the administrative team has collected data about professional development needs/wants for the following school year the team will look at OTES and OPES professional goals to see what areas of need there are of the current staff structure at The Edge Academy. To ensure that the professional development that is provided in August and October is aligned with the Ohio Standards for Professional Development the team will create a rough draft of what professional development will be offered and the director and curriculum coordinator will insure that it

falls into one of the 7 standards including learning communities, leadership, resources, data, learning designs, implementation, and outcomes.

The administrative team will ensure that the professional development is differentiated based on individual teacher needs. The team will look at OTES data and local assessment data to find gaps in teacher's instructional practices. The team will then determine based on individual teacher needs what professional development should be provided that is linked to the schools OIP goals and will meet the needs of the low social economic status of students that the teachers will be instructing. The administrative team will ensure implementation of the professional development through formal and informal observations in the OTES and OPES system. The CSLT will then look at the data to see if the professional development that is being implemented is having a positive correlation on student achievement. The CSLT will also review data to assure that the school's OIP goals for math and reading are being achieved. If not, the CSLT and administrative team will decide the best way to implement research-based strategies to better assist our staff and students.

The data will be from many sources such as data gathered during walkthroughs, OTES, OPES, MAP testing, and OST tests(Indicators 4.1.1, 4.1.2, 4.2.2, 1.1.1, 1.3.1). We will look at what gaps in learning are occurring as a team of school stakeholders(indicators 1.2.2, 1.3.2, 2.3.2, 3.2.1, 4.2.2). As we take those gaps we will look at programs that are research valid that will ensure student success(indicators 4.2.2,4.2.3,1.3.2,3.1.2,7.2.2). Many of these research valid programs are centered on several years of work in order for the school to see growth. Once we have determined a program, the stakeholder team will send

out a survey to the professionals asking about what they know about the program and how it would help them professionally(indicator 1.3.1,1.3.2,2.1.2,3.1.2,5.3.1). The stakeholder team will then look at the program to see if that program will fill in the gaps that the school and professionals need. Once this is all determined, we will make sure that our budget will allow the program and make the necessary contacts needed. If we need grant money for the program we will work as the team to write any grants in order to procure the program needed. Once this is all taken care of, we will have a professional development from that program. At the end of the professional development we will have the professionals fill out a survey. The administrative team will ensure implementation of the professional development through formal and informal observations in the OTES and OPES system. This data is gathered and sent to the CSLT. The CSLT will then look at the data to see if the professional development that is being implemented is having a positive correlation on student achievement. The CSLT will also review data to assure that the school's OIP goals for math and reading are being achieved(indicators 4.1.2, 4.2.2, 4.3.2, 4.3.4).. If not, the CSLT and administrative team will decide the best way to implement research-based strategies to better assist our staff and students.

Professional Development Plan for School Leaders

6.3d

9) Using the Ohio Standards for Principals 2018, describe how the school will *develop, implement, and evaluate* a differentiated professional development plan for school leaders informed by student data, curriculum needs, OTES, OPES, IPDPs, Resident Educator Program, etc. and how it will link to the school's continuous improvement plan.

School leaders will be evaluated appropriately in accordance to OPES. This will be done by the Superintendent/Director of the school. The school leaders will be held to the same standards as the teachers along with the added responsibility as to the success of the teachers they oversee. The school leaders have the same expectations as teachers in being evaluated, making growth plans, and creating goals based on the OIP.. The school leaders however are expected to be academic leaders by running TBT, BLT, and being involved in reviewing academic data and results. The administrative team professional development involves the progressing of knowledge of what and how students learn, but also include how to most efficiently lead and grow teachers/staff members.

School Calendar	6.3.1	9) Provide the proposed school calendar, including how parents and students will be notified. It must be comprehensive with professional development and assessment days, vacation days, and number of hours the school will be in session. The school calendar will need to be submitted annually by a due date established yearly for approval by the Sponsor and ODE. Once the calendar is approved, changes can only be made for limited reasons with approval of the sponsor and ODE, and may require a corrective action plan.
------------------------	--------------	---

To be approved at board meeting on March 18th 2019 for 19-20 calendar (see attachment)

Once the schedule is approved, it will be posted on the school website and sent home to each parent, board member and staff member.

To be approved at the board meeting March 18th 2020 for 20-21 calendar (see attachment)

Once the schedule is approved, it will be posted on the school website and then sent home to each parent, board member, and staff member.

Bell Schedule	6.3.1	10) Provide the school's proposed bell schedule(s). The bell schedule must incorporate all core and non-core content areas. The schedule must demonstrate common planning time for teachers. Please include the number of hours per day. If additional services are provided, such as after-school tutoring, include these on the schedule.
----------------------	--------------	--

****Times may vary due to unique student needs or school events****

Kindergarten Schedule

7:40-8:10 Arrival, Breakfast, Morning Work

8:10-8:20 Morning Meeting
8:20-8:30 Calendar
8:30-9:00 Literacy
9:00-9:30 Phonics
9:30-10:05 Writing
10:05-11:00 ELA Centers/RIMP (T OT push in)
11:00-11:40 Math
11:40-12:10 Kindergarten Reading Groups
12:15-1:00 Lunch and Recess 1:00-1:20 Drinks, Potty, sight words
1:25-2:10 Specials
2:15-2:35 DEAL
2:35-2:45 End of the day chores and pack up
1st grade Schedule
7:40-8:00: Kid's Breakfast and Morning Work
8:00: Announcements
8:05-8:20: Attendance and Morning Meeting
8:20-8:55: 1st Grade Reading Groups
9:00-10:10: ELA (Reading, Writing Spelling)
10:10-10:20: Snack/Brain Break
10:20-11:30: Math
11:30-12:10: Science/SS
12:15-12:45: Lunch and Recess
1:00-1:20: Extra ELA, Math, SS/Science
1:25-2:10: Specials
2:15-2:35: DEAL Time/Groups

2:35-2:45: Clean up/Get Things/Folders/Dismissal

2nd grade Schedule

7:40-8:00 In Room Greeting students/Attendance/Announcements
8:05-8:30 Math RTI
8:35-9:20 Specials (Planning)
9:30-10:05 Reading
10:10-10:45 Small group Reading
10:55-11:05 Snack/silent read or read aloud
11:05-11:25 Writing
11:30-12:10 Math
12:15-1:00 Lunch/recess
1:15- 1:45 Spelling/Grammar
1:45-2:15 Science/Social Studies/extra math
2:15-2:35 Deal Time
2:35-2:45 get ready to go/HW time

3rd grade Schedule

7:40-8:00: Kid's Breakfast and Morning Work
8:00: Announcements
8:05-8:30: RTI Math
8:35-9:20: Special
9:30-10:05: Small group reading
10:10-11:10: ELA 3A/3B Math
11:15-11:45: Lunch
11:50-12:10: Social Studies 3A/3B Science
12:10-12:25: Homework

12:30-1:35: ELA 3B/Math 3A
1:35-1:55: Social Studies 3B/3A Science
1:55-2:10: Homework
2:15-2:35: DEAL Time

4th and 5th grade Schedule

7:40-8:00: Kid's Breakfast and Morning Work

8:00-8:05 Announcements

8:10-9:38: 5B Math 5A Reading 4A Reading 4B Math

9:40-11:10: 5A Math 5B Reading 4B/4A S.S. and Science

11:15-11:45: Lunch

11:50-12:35: Specials

12:40-2:10: 4A Math 4B Reading 5B/5A S.S. and Science

2:15-2:35: DEAL TIME

2:35-2:45: Prepare for Dismissal

Collaborative Planning takes place while classes are at their "Specials" classes.

TBT Every Tuesday 3:00-3:45

6.3e Prevention and Intervention Policy

A *Comprehensive System of Learning Support Guidelines*, an Ohio State Board of Education approved document (link provided below), provides direction for foundation and intervention services to students to assist with the development of necessary systems to meet the unique needs of students. <https://education.ohio.gov/getattachment/Topics/Other-Resources/School-Safety/School-Safety-Resources/Comprehensive-System-of-Learning-Supports-Guidelin/Brochure-fulfillingthepromise.pdf.aspx>

Appropriate implementation of the guidelines will result in school meeting or exceeding RC 3313.6012 requirements to (1) provide diagnostic assessment procedures, (2) provide intervention services based on the results of the diagnostics, (3) collect data regularly, and (4) use the data to evaluate the effectiveness of the interventions. Please provide strong evidence and specific details to address the items below.

Prevention and Intervention Plan	6.3.2	<p>1) Describe a whole-child model for meeting students' needs related to health, safety, engagement, personalized learning and prepared for success.</p> <p>2) Describe the school's multi-tiered educational services policy, plan and procedures to provide early detection and intervention for your at-risk (NOT identified special education students) experiencing academic and/or behavior problems, and address the needs of <u>ALL</u> students (i.e. limited English proficient, gifted, Third Grade Reading Guarantee, homeless, lowest achieving 20%).</p>
----------------------------------	-------	---

Assessment and Academic Prevention/Intervention Services Procedures

A. Procedures for Using Diagnostic Assessments to Measure Student Progress in Accordance with Academic Standards

The school administration shall assess student achievement and needs in all program areas in compliance with State law and the rules adopted by the State Board of Education. The purpose of such assessments will be to determine the progress of students and to assist them in attaining student performance objectives and the educational achievement goals of this school.

School administration and staff shall administer the state-mandated tests to students at the times designated by the State Board of Education. The Board may, for medical reasons or other good cause, excuse a student from taking a State-mandated test on the date scheduled, but any such test shall be administered to such excused student within the testing window.

The school board shall require that all staff have knowledge of the prescribed standards of ethical assessment practice and shall monitor the assessment practices for compliance with these standards. These duties shall include:

- A. communicating standards of ethical assessment practice;
- B. communicating security procedures for assessment;
- C. establishing procedures for reviewing assessment materials and procedures and assessment preparation materials and procedures;
- D. establishing channels of communication that allow staff, students, parents, and other members of the community to voice concerns about assessment practices;
- E. establishing written procedures for investigating complaints, allegations, and/or concerns about assessment practices, protecting the rights of an individual, the integrity of an assessment, and the identify the Level per ESSA results of an assessment.

At least three times annually, staff members will assess the academic achievement and learning needs of each student. Procedures for such assessments may include, but need not be limited to, teacher observations, cumulative student records, student performance data collected through standard testing programs, and physical examinations.

B. Plan for the Design of Classroom-Based Intervention Services to Meet the Instructional Needs of Individual Students as Determined by the Results of the Diagnostic Assessments

For any student who fails to receive a proficient score on the diagnostic testing, the school staff will meet to decide what interventions will be provided for the student. Staff members will work with students to set a realistic and attainable goal in the area of their deficiencies.

The school shall provide academic intervention services in pertinent subject areas to students who score below the proficient level in English language arts, mathematics, social studies, or science in the diagnostic testing.

The school will provide varied levels of intervention dependent upon student scores and staff recommendation.

- Tier 1 services are the same for ALL students. We take preventive and proactive practices and supports designed for basic remediation and will include such services as, but not limited to: proximity to teacher, avoidance of distracting stimuli, simplification of multi-step directions, providing visual aids, provide open-book or take home tests, adjusting privileges, rewards and/or consequences, and other interventions deemed necessary by staff or school administration.
- Tier 2 services are for those students that scored progressively lower on their diagnostic assessments or students not making adequate progress in the core curriculum subject areas who are then provided with increasingly intensive instruction matched to their needs on the basis of levels of performance and rate of progress. These interventions include but are not limited to: daily behavioral form, teaching social skills, use of sensory tools, using non-verbal cues and signals, small group instruction, one-on-one instruction as needed, and other interventions deemed necessary by staff or school administration.
- Tier 3 students receive small-group and/or individualized, intensive interventions that target the student's skill deficiencies for the remediation of existing problems as well as the prevention of the most severe problems. These interventions include but are not limited to: receiving individualized, intensive interventions that target the student's skill deficiencies in a least-restrictive environment. These interventions include change of placement and one-on-one instruction.

In all tiers, staff is required to monitor growth using data from diagnostic tests, personal observations, cumulative student records, student performance data, summative and formative assessments given by a core subject instructor, and any other data collected as deemed relevant by school administration.

In all tiers, staff shall use data to differentiate instruction and interventions consistently for all students and evaluate effectiveness of interventions used.

C. Procedures for the Regular Collection of Student Performance Data

The administrative staff shall develop a program of testing to be approved by the school board that includes, but is not limited to:

- A. administration of State-mandated tests (e.g., AIR assessment)
- B. Curriculum based assessments
- C. Teacher-created achievement tests

D. Nationally-normed diagnostic assessment (e.g. MAPS tests)

"State-mandated tests" means any assessment that is provided by the Ohio Department of Education (ODE) for use in all participating schools in the State. The data for the state mandated tests are to be collected as set forth by ODE. Once in the Spring of every year (except for grade 3, who will take the 3rd grade reading test in the fall of each year for the 3rd grade reading guarantee.)

"Curriculum based assessment" means the use of an assessment aligned with the Ohio academic content standards, designed to measure a student's level of knowledge of a basic skill as taught using a grade and subject specific text. The data for this assessment will be collected by core subject teachers at least once per month.

"Achievement test" means a test aligned with the Ohio academic content standards, designed to measure a student's level of knowledge or skill in a specific subject area that is expected to be learned within a designated grade. The data for this assessment will be collected by core subject teachers at least once per quarter.

"Diagnostic assessment" means an assessment aligned with Ohio academic content standards, designed to measure student comprehension and growth of knowledge within a specific academic content area and mastery of related skills for a relevant subject area within a designated grade level. The data for this assessment will be collected by core subject teachers three times a year. Once in September, once in December, and once in March.

D. Procedures for Using Student Performance Data to Evaluate the Effectiveness of Intervention Services and, If Necessary, to Modify those Services

Staff shall execute continuous progress-monitoring for each student placed into a tier 1, 2, or 3 interventions and report their findings to school administration. This progress-monitoring should be completed at least once a month and may consist of, but not limited to: teacher observations, curriculum assessments, diagnostic assessments, and state testing.

2 School administration and staff will assess a student's progress quarterly toward meeting their intervention goal(s) and determine if the current interventions should be continued or if other interventions must be established within/among the student's current interventions.

If student has shown little to no growth, administration and staff may move the student to the next tier for more intensive interventions.

Here is the board approved MTSS process that was not in the original ed plan.

The School strives to provide instruction for all students. All students receive Tier 1 supports in the classroom and are for the entire population. For a certain percentage of students the Tier 1 supports are not effective and students need more support to be successful.

Tier 1: -Core Academic/Behavior for the entire population

Academics: All students in tier 1 receive high quality research based instruction from general education teacher in the core curriculum. The core curriculum provides the foundation for which all strategic and intensive intervention are formulated. Tier 1 instruction occurs in the general education setting with teachers giving special attention to the needs of the students through differentiated instruction which are directly aligned to the state standards.

Behavior: School wide PBIS expectations are aligned to tier 1 interventions and used for all students. They map out procedures and processes through a set of behavioral expectations for the entire school.

Universally Screen ALL STUDENTS (MAP, KRA, ELPA21)

**Approximately 20% of students may need additional support **

Tier2: Intervention (20% of the population) as identified by universal screener and agreed upon by MTSS team. All students in Tier 1 must have paper documentation.

Academics: Students in Tier 2 receive specific research based targeted instructional strategies. They can be provided in the general educational classroom or small group setting. Students will be progress monitored weekly using school wide assessment program.

- Phonics instruction
- Arrive Math
- Extended time
- Alternate pathways to show mastery
- Independent Study
- Small group

Behavior: Students in Tier 2 receive specific research based targeted strategies to decrease problematic behaviors/difficulties within the classroom.

- Parent contact
- Structured schedule
- Behavioral contract
- Change of instructional placement
- Check in
- Modeling correct behavior

Tier 3: Intensive Intervention (5% of population). This does not mean students will qualify for special education referral or that students in Tier 3 are only special education students.

Academics: Students in Tier 3 receive intensive interventions based on the need for increased individualized specific targeted

interventions that is not being met with Tier 2 interventions. Students focus on more specific skills that pose the greatest barrier to the acceleration of student learning.

- Individual or very small group instruction
- Increased time of practice
- Schedule change
- High interest lessons
- Positive corrective feedback

Behavior: Students in Tier 3 receive individualized intensive instruction based on students specific behavioral needs. Students in Tier 3 typically have 60% more discipline incidents as identified by the behavioral support team than Tier 1 students.

- Functional Behavioral Analysis
- Behavioral Improvement Plan

6.4a Goals and Performance Indicators

The school will be required to show progress toward meeting the goals established in its OIP School Improvement Plan. The OIP School Improvement Plan will be reviewed at monthly board meetings and updated as needed. Revised plans will be submitted to the Sponsor.

Schools newly chartered with Charter School Specialists will establish an OIP School Improvement Plan by September 30th.

The sponsor will provide accountability standards, which include but are not limited to, all applicable report card measures set forth in R.C. 3302.03 or R.C. 3314.017.

6.5 Assessment Plan

The Assessment Plan should enable the school to make an accurate reference as to what students should know and be able to do. It should align to the desired learning outcomes of the curriculum.

Nationally Normed Assessment

6.5

1) St. Aloysius requires its sponsored schools to identify and utilize at least one nationally normed, [ODE approved standardized testing tool](#). It is mandatory that the assessment be administered a minimum of twice per year and the administration should be identified on the school calendar. Which Nationally Normed Assessment will be used? Discuss rationale for assessment selection and the relationship to Student Growth Measures (OTES and OPES). Nationally normed assessment data and a comprehensive written analysis will be due to the sponsor by June 30th of each year.

The school will be using MAP assessment for the nationally normed assessment. We decided to MAP test starting the 2017-2018 school year and have continued. This test has been effective for a couple of core reasons: 1. It can be used in place of several assessments saving staffing time and money on other assessments (used for diagnostics in K-3 and alternative 3rd grade reading guarantee assessment). 2. The assessment is individual normed to ensure every student has a different test and based on the ability of the students the questions get easier or harder until the mean of the student ability is reached. 3. MAP provides more data based on students individual score than other tests we have used in the past (AimsWeb).

The assessment will be given 3 times a year as a benchmark in fall, winter, and spring. MAP progress monitoring assessment will be given monthly to progress monitor all students who are in RTI, special education, or on a RIMP. This assessment was chosen because it is ODE approved vendor. The assessment will be used for the student growth measure for all teachers who do not have value added data in the OTES system. It will also be used for part of the data in OPES.

Ohio's State Assessments

6.5

2) All required state assessments must be included in the school's assessment blueprint and calendar. Confirm use of specific state tests, how the data will be collected and distributed to Board of Directors, staff, students, parents, and how the results will impact professional development and Ohio Improvement Process (OIP) goals and strategies. These may include required grade level state assessments, End of Course Exams, Industry Credentialing, ACT/SAT, WorkKeys, OELPA, and Kindergarten Readiness

Assessment.

All state assessments will be given to all students that are eligible: including but not limited to the KRA, OELPA, Alternative Assessment, and Ohio's State Assessment.

KRA week of September 1st

MAP assessment for diagnostic and RIMPS occur in the 3rd week of September.

3rd grade fall ELA assessment occur in the 3rd and/or 4th week of October.

OELPA occurs in the first week of February

3-5 ELA State assessments: occur within the first two weeks of the state of Ohio's testing window

3-5 math and science state assessments: occur within the last two weeks of the state of Ohio's testing window

Data is collected when scores become available in the Summer. The administrative team looks at all data and distributes it to the board in the summer board meeting, to parents during open house, and teachers during August training dates. As the administrative team analyzes the data the review the OIP and look at areas of focus for August training.

Data is collected when score scores become available.

Teachers use this data throughout the school year to differentiate their teaching and classroom to meet the needs of all students and structure their lessons making sure they are "hitting" the main objective in the content standard

Formative Assessments**6.5**

3) Describe the process for developing formative assessments that includes gauges of all learning domains (social-emotional), sharing data across grade levels and with students and parents, and how results will impact instructional strategies, practices, materials selection and professional development.

Formative instructional assessment practices will be implemented in all classrooms throughout The Edge Academy. The teachers will use formative assessment tools such as; exit tickets, thumbs up or thumbs down, TurningPoint clickers, Parking Lot questions from students, etc.

The data collected in TBTs from formative assessments will be analyzed and will impact on what student needs are within each TBT band and what instructional strategies/tools are having the most positive impact on student achievement. The data analyzed will also allow the CSLT team to look at and decide if there is a need for professional development in certain area based on student data.

Non-Academic Measures	6.5	4) Describe non-academic measures such as parent and student satisfaction surveys, student interest surveys, etc. that might inform school practices and program effectiveness.
------------------------------	------------	--

At the end of each school year, parent and student surveys are sent home and then reviewed over the summer to analyze feedback about the school including program effectiveness.

Diverse Measures of Student Performance	6.5	5) Identify diverse ways to measure student performance beyond standardized assessments that include tools such as student portfolios, capstone projects, presentations or performance-based assessments.
--	------------	--

The students throughout the year will create leadership notebooks. These notebooks will keep data and students works throughout the year. The students in higher grades will have the opportunity to lead parent teacher conferences and review their notebooks with their parents in these conferences.

8.1 Organization and Staffing

Personnel and understanding of roles and responsibilities are critical for successful school operation. Please provide strong evidence and specific details to address the items below.

Organizational Chart	8.1	1) Provide the school's organizational chart with clear identification of all positions including fiscal officer, EMIS and Management Company (if applicable).
-----------------------------	------------	---

See attached—is now attached

<p>Roles and Responsibilities</p>	<p>8.1</p>	<p>2) Describe the roles and responsibilities of school staff aligned to the organizational chart and mission, vision, and philosophy of the school: a) administrative, b) teaching, c) specialized, d) contracted services (i.e. speech and language pathologist, school psychologists, etc.), e) other. <i>Please only include job titles.</i></p>
<p>The Board of Directors is responsible for developing the policies and procedures of The Edge Academy and ensuring that the operations of the school are in line with the policies. The Director is responsible for the educational operations and reports to the Board of The Edge Academy. The teachers, instructional aides, office staff, administrators, and curriculum coordinator/academic coach report directly to the Director. The Treasurer reports directly to the Board of Directors. Teachers will oversee the daily activities of the Instructional Aides and provide feedback</p> <p>The teachers, instructional aides, office staff, administrators, and curriculum coordinator/academic coach report academic coach report directly to the Director. The academic coach is responsible for the lesson plan integrity (are the staff using the appropriate Ohio Content standards) and working directly with the teachers to ensure that students are getting the content and instruction needed. The Treasurer maintains the school finances and makes sure the school is fiscally responsible per all Ohio regulations. They reports directly to the Board of Directors. The teachers are responsible for maintaining student records and following all school policies to ensure the academic success of all students.</p> <p>The school contracts out their OT, PT, speech therapy and school psychologist. Their contracts are board approved and reviewed at the end of each year to assure that the services being provided meet the needs of the students and staff. The contracted staff reports to the director and special education director.</p>		
<p>Recruitment and Retention Plan</p>	<p>8.1</p>	<p>3) Describe the plan to recruit, retain and train highly qualified personnel including how the school will meet the goals identified in Ohio’s 2015 Plan for Equity at ODE’s website at: https://education.ohio.gov/getattachment/Topics/Teaching/Educator-Equity/Ohio-s-Teacher-Equity-Plan-and-EDHEE-Analysis-Tool/Ohio-s-2015-Plan-to-Ensure-Equitable-Access-to-Excellent-Educators102615.pdf.aspx.</p>

Recruitment and Retention Plan

In effort to meet the goals of Ohio's 2015 Plan to Ensure Equitable Access to Excellent Educators, The Edge Academy will develop and follow the plan listed below.

The Edge Academy is a high minority, high poverty school. The amount of inexperienced teachers at 16%. There is 100% HQT as they were hired with that status.

The CSLT gathered with leadership and teachers. The equity gap data findings were reviewed from the Equitable Access Analysis Tool. The group listed a root cause analysis of the most concerning gaps identified in Item 3 (data analysis). The root cause analysis process revealed that the systems challenge at The Edge Academy relates to the inexperience of the teachers. Professional development is approached by the needs of each individual teacher to help them be successful within the classroom. They need to continue this practice as the teachers are gaining valuable experience.

The Edge Academy will engage in targeted professional development that is based on findings from OTES/OPES. This will help to impact teacher performance in those areas of targeted professional development. The academic coach will provide guidance and support as needed in efforts to increase effective instruction, assessment and school improvement scores. The Edge Academy will incorporate higher education partnerships for professional development and clinical field experience opportunities.

The administrative team will begin in April looking at the staffing needs for the upcoming school year based on the current staff filling out their intent to return forms. Once the administrative team has reviewed the intent to returns they will go to various teaching job fairs and post open position to K12hotjob. The team will begin to review resumes in May and have interviews completed by end of May to ensure offer letters to retuning staff and new staff are given to all members on or before the last day of school for staff.

Student/Teacher Ratios	8.1	4) State the student/teacher ratios for the school. <i>Ratios can be no more than 29 students to 1 teacher (29:1).</i>
The maximum student teacher ratio of The Edge Academy is 25:1		
Staffing Plan for Projected Enrollment	8.1	5) Describe the staffing plan (for the next 5 years) based on the projected enrollment and differentiate between certified teaching, para-teaching, and non-licensed staff.

Staffing Plan

For the purpose of allocating funds and meeting the needs of the students at the Edge Academy, it is important to set up a procedure that will be as fair and accurate as possible. The following procedure is used:

Step 1 Calculate enrollment and trend projections from the previous four years using EMIS Data (knowing that Edge Academy has a max capacity of 288)

Step 2 Project next grade memberships for 2018-2019 school year.

Step 3 Review special education needs for the upcoming school year (1-on-1 aides and ensure ratio is below 16:1)

Step 4 Look at staff intent to return forms to see if anyone plans on retiring, leaving, or wants to move to a different position

Step 5 Once all data has been reviewed by the administrative team, director, and human resources manager a needs assessment will be created for the upcoming school year. The needs assessment will be broken into 3 categories: 1. Certified staff 2. Non-licensed staff 3. Para professionals and 4. Administrative needs

Step 6 After the needs assessment has been completed the administrative staff will place teachers in positions based on their qualifications and placement preferences. If there is a large change in enrollment more or less para professionals and title one teachers may be needed

For the 2019-2020 school year the school had an enrollment of 225; with 12 classroom teachers, 3 intervention specialists, 1 title teacher , 4 paras, 3 special teachers, 1 principal, 1 dean of students, 3 academic coaches, a director of special education, and superintendent/director.

For the 2020-2021 school year the projected school enrollment is 235; projected 12 classroom teachers, 3 intervention specialists, 1 title teacher, 4 paras, 3 special teachers, 1 principal, 1 dean of students, 3 academic coaches, a director of special education, and superintendent/director.

For the 2021-2022 school year the projected enrollment is 245; projected 12 classroom teachers, 3 intervention specialists, 1 title teacher, 4 paras, 3 special teachers, 1 principal, 1 dean of students, 3 academic coaches, a director of special education, and superintendent/director. The projected enrollment numbers still stay within the 25:1 student to teacher enrollment.

The school projects an enrollment not to exceed 288 students. Once the enrollment exceeds 25 students per class a waiting list and lottery will be put into place. There will be two classrooms per grade. Currently the projected enrollment of special education students is 26. There are 3 special education teachers to meet the needs of these students and 3 special education paras. If the number of students exceeds 45 another special education teacher will be hired to stay in compliance. The school also will have 1 title teachers and 2 paraprofessionals to meet the needs of the students. The school will also have an academic coach to help with staff development and instructional support. There will be 2 administrators for the building.

To be sent in from Mrs. DeCesare

Performance Framework

This framework describes a comprehensive system of monitoring a community school’s performance and compliance. This rigorous framework will be used to inform renewal and revocation decisions. The goal for each school is to achieve a 75% or greater of the available points based on academic, compliance/operations and financial performance. The Sponsor believes that completing the interventions per the Intervention Attachment 6.4 may assist the School in increasing their performance and helping them to achieve 75% or greater of the available points in the academic performance section. Annually, the School will be sent a performance report showing its percentage over a certain number of years. The goal is for each School to reach 75% by the end of its fifth year of operation.

During a renewal year, the school will be evaluated on an average calculated over the four most recent years of the charter term or the number of years within the charter term that data is available. Schools may earn additional points for improvement in the total percentage from year to year.

TRADITIONAL K-12 COMMUNITY SCHOOLS

Academic Performance

Performance Area	Description	Scoring Scale									
		Above Target				Target	Below Target		Far Below Target		
		5 Points	4.5 Points	4 Points	3.5 Points	3 Points	2.5 Points	2 Points	1.5 Points	0.5 Points	0 Points
		Overall Rating *Not calculated until SY 2022-2023	Overall Rating on the Local Report Card	5 Stars (weighted x 3)	4.5 Stars (weighted x 2.5)	4 Stars (weighted x 2)	3.5 Stars (weighted x 2)	3 Stars	2.5 Stars	2 Stars	1.5 Stars

*Schools will receive 0.5 points based on a 1 Star rating if the schools’ overall rating points are greater than or equal to the average overall rating points of all community schools.

Performance Area	Description	Scoring Scale			
		Above Target	Target	Below Target	Far Below Target
		4 Points	3 Points	1 Point	0 Points
Overall Rating vs Comparison Schools Overall Grade *Not calculated until SY 2022-2023	Number of schools in which the total points used for the Overall Rating on the Local Report Card is higher than the total points used for the Overall Rating of comparison schools listed in contract.	Outperform 4 or 5 comparison schools (weighted x 3)	Outperform 3 comparison schools (weighted x 2)	Outperform 2 comparison schools	Outperform 1 comparison school
Performance Area	Description	Scoring Scale			

		Above Target		Target	Below Target	Far Below Target
		4 Points		3 Points	1 Point	0 Points
Achievement *Schools will receive 1 point based on a 1 Star rating if the schools' overall achievement percentage is greater than the average overall achievement percentage of its comparison schools that also received a 1 Star rating.	Measures students' academic achievement using each level of performance on Ohio's State Tests.	5 Stars (weighted x 2)	4 Stars (weighted x 2)	3 Stars (weighted x 2)	2 Stars (weighted x 2)	1 Star*
Progress *Note: as reported on the local report card as the progress component score. Not ODE's one year calculation as used for closure.	Measures the academic performance of students compared to expected growth on Ohio's State Tests.	5 Stars (weighted x 3)	4 Stars (weighted x 2)	3 Stars	2 Stars	1 Star
Gap Closing *Schools will receive 1 point based on a 1 Star rating if the schools' overall gap closing percentage is greater than the average overall gap closing percentage of its comparison schools that also received a 1 Star rating.	Measures the reduction in educational gaps for student subgroups. *Now includes Chronic Absenteeism	5 Stars (weighted x 3)	4 Stars (weighted x 2)	3 Stars	2 Stars	1 Star*
Early Literacy *Schools will receive 1 point based on a 1 Star rating if the schools' overall early literacy percentage is greater than the average overall early literacy percentage of its comparison schools that also received a 1 Star rating.	Measures reading improvement and proficiency for students in kindergarten through third grade.	5 Stars	4 Stars	3 Stars	2 Stars	1 Star*
Performance Area	Description	Scoring Scale				
		Above Target	Target	Below Target	Far Below Target	

		4 Points		3 Points	1 Point	0 Points
Graduation Rate	Measures the four-year adjusted cohort graduation rate and the five-year adjusted cohort graduation rate.	5 Stars	4 Stars	3 Stars	2 Stars	1 Star
College, Career, Workforce, and Military * Not rated until 2024-2025	Tracks post-graduation outcomes and students participating in credentials and pathways.	5 Stars	4 Stars	3 Stars	2 Stars	1 Star
Nationally Normed Assessment Data	A standardized assessment listed in the community school contract should demonstrate at least one (1) years' worth of growth for 80% of students tested in reading and math using the Ohio's Where Kids Count Rules.	≥ 1 years' worth of growth for 80% of students tested in reading and math		≥ 1 years' worth of growth for 50% of students tested in reading and math	< 1 years' worth of growth for 50% of students tested in reading and math	N/A
Additional Factors:	One additional point is given for each of the indicators above that has improved at least one star level from the previous year (ex. K-3 moves from 2 Stars to 3 Stars)					
	One additional point given for each subgroup in which the suspensions and expulsions decrease by 2 percentage points.					
	One additional point given if school increases the number of schools it outperforms in either the Overall Rating or the Progress Rating. (ex: improves from outperforming one school to outperforming two schools)					
	One additional point is given if the school's percentage of income spent on classroom instruction is within 10% of the state average as reflected on the local report card. School will receive 2 additional points if its percentage of income spent on classroom instruction is above the state average as reflected on the local report card.					

<p>Total Points Available (100%): *Note: Weighting is not considered in the total points available and total possible points are reduced for any not applicable measures listed.</p>		3
		2022-2023 33 *Based on 2022-2023 local report card
		2023-2024 and beyond 37 *Based on local report cards starting with 2023-2024
<p>Target Points (at least a 75%): *Note: Points listed will be achieved if the school meets all target scores for all applicable measures.</p>		2021-2022 18 *Based on 2021-2022 local report card
		2022-2023 24.75 *Based on 2022-2023 local report card
		2023-2024 and beyond 27.75 *Based on local report cards starting with 2023-2024

DROP OUT RECOVERY PROGRAM COMMUNITY SCHOOLS

Academic Performance

Performance Area	Description	Scoring Scale		
		Above Target	Target	Below Target
		4 Points	3 Points	0 Points
Overall Grade	Overall Grade on the Local Report Card	Exceeds (weighted x 2)	Meets	Does not Meet
Overall Grade vs Comparison Schools Overall Grade	Number of schools in which the Overall Grade on the Local Report Card is higher than the Overall Grade of comparison schools listed in contract. *If a school scores equal to a majority of its comparison schools in Overall Grade, the school will be compared in the Progress Component Grade. The school will then be given credit for each school it outperforms in its comparison group in the Progress Grade and each school it outperforms in the Overall Grade.	>3 (weighted x 3)	≥ 2 (weighted x 2)	≥ 1
High School Test Passage Rate	Percent of students meeting applicable criteria on test from Local Report Card	Exceeds	Meets	Does not Meet
Progress	Component grade from Local Report Card	Exceeds	Meets	Does not Meet
Gap Closing	Overall Gap Closing Grade on the Local Report Card	Exceeds	Meets	Does not Meet
Graduation Rate – 4 Year	4-Year Graduation Rate from the Local Report Card <small>*Students enrolled in DOPR schools are usually 1-2 years behind their original graduation cohort.</small>	Exceeds (x2)	Meets (x2)	Does not Meet (1 point)
Graduation Rate – 5 Year	5-Year Graduation Rate from the Local Report Card	Exceeds	Meets	Does not Meet
Graduation Rate – 6 Year	6-Year Graduation Rate from the Local Report Card	Exceeds	Meets	Does not Meet
Graduation Rate – 7 Year	7-Year Graduation Rate from the Local Report Card	Exceeds	Meets	Does not Meet
Graduation Rate – 8 Year	8-Year Graduation Rate from the Local Report Card	Exceeds	Meets	Does not Meet
Combined Graduation Rate	Combined rate from the Local Report Card	Exceeds	Meets	Does Not Meet

Performance Area	Description	Scoring Scale		
		Above Target 4 Points	Target 3 Points	Below Target 0 Points
Identified Paths to Future Success	Strategy 10 of Ohio's Strategic Plan for Education: High schools inspire students to paths of future success through work-based learning experiences; career-technical education and/or military readiness.	School offers multiple paths of future success AND 50% or more of the eligible student population participate in those paths (work-based learning experiences, career technical education, career-based instruction or military readiness.	School offers limited paths of future success through work-based learning experiences, career-technical education/industry credentialing, career-based instruction or military readiness.	School does not offer paths of future success through work-based learning experiences, career-technical education/industry credentialing, career-based instruction or military readiness.
Additional Factors:	One additional point is given for each of the indicators above that has improved at least one grade level from the previous year (ex. Progress moves from Meets to Exceeds)			
	One additional point is given for each subgroup that improves its attendance percentage by 2 percentage points.			
	One additional point given if school increases the number of comparison schools it outperforms in the Overall Local Report Card Grade as listed in the contract from 2 to 3 schools, from 3 to 4 schools or from 4 to 5 schools.			
Total Points Available (100%) *Note: Weighting is not considered in the total points available.				48
Target Points (at least a 75%)				36 *Note: 36 points are achieved if the school meets all target scores.

Organizational/Operational Performance

Performance Area	Description	Scoring Scale		
		Above Target	Target	Below Target
		2 Points	1 point	0 Points
Timely submission of required documentation.	Monthly Financial and Enrollment Reports, Assessment data, Management Company Evaluation, school improvement plan, Annual Report, Five-year forecasts and Annual Budgets are submitted timely.	All Applicable Submissions were Submitted Timely	At least 75% of the applicable Submissions were submitted timely	Less than 75% of the applicable submissions were submitted timely
Compliance Onsite Visits including Spring Survey (As measured by the Ohio Department of Education Sponsor Evaluation System)	Overall performance of onsite compliance reviews and the spring survey	Overall Compliant (96% or greater of applicable compliance items substantiated)	Substantially Compliant (at least 92-95.9% of applicable compliance items substantiated)	Not Compliant (less than 92% of applicable compliance items substantiated)
Corrective Action Plans	Were corrective action plans required during this school year.	No CAPs required	Yes, at least one CAP was required, however all issues were adequately addressed	Yes, at least one CAP was required, and was still unaddressed by the end of the school year
Probation	Was the school put on probation during this school year	No *Target	N/A	Yes
Board Meetings	School met for mandatory minimum six (6) board meetings	No less than six (6) meetings *Target	N/A	Board met less than six (6) times for the year.
Additional Factors	One additional point is given if academic coaching is provided for teachers if recommended by the School Improvement Team.			
	One additional point is given for each mission-specific goal that is met for any subgroup, up to a maximum 3 points.			
Total Points Available (100%) *Note: Weighting is not considered in the total points available.				10
Target Points (at least a 70%)				7 *The school should strive to achieve 7 points in this section by achieving a combination of target and above target points.

Financial Performance

Performance Area	Description	Scoring Scale		
		Above Target	Target	Below Target
		2 Points	1 Point	0 Points
Net Income (Change in Net Position) Net of GASB 68,75	Positive Net Income	Positive Net Income (x2) *Target	N/A	Negative net income
Average FTE Change from beginning of year to end of year calculated from October to June.		Increased or maintained enrollment and compliant with enrollment requirement in contract (x2)	Enrollment decreased less than 10%	Enrollment decreased greater than 10%
Current Ratio (Current Assets/Current Liabilities, net of GASB 68/75 and amounts owed to Management Company)		Ratio greater than 1.5:1	Ratio 1:1 to 1.49:1	Ratio less than 1:1
Days Operating Cash on Hand *Note: this section will be an N/A for all pass-through management agreements and the total points required will be reduced accordingly.		Greater than 60 days	30 to 59 days	Less than 30 days
Five Year Forecast		No projected deficits in years 1-5.	No projected deficits in years 1-3	Projected deficits in years 1-3.
Audit Reports, Findings for Recovery (FFR)		No FFRs and clean audit opinion	Clean audit opinion and all FFRs have been corrected	FFRs not corrected or qualified opinion
Additional Factors	One additional point will be given for schools that have EMO/CMO supporting the schools start-up/expansion expenses.			
Total Points Available (100%): *Note: Weighting is not considered in the total available points				12
Target Points (75%)				9



Intervention Attachment 6.4

Kindergarten – 12th Grade

(A school that does not offer a grade higher than twelve excluding Dropout Prevention & Recovery Schools)



➤ **Evaluation of Local Report Card Components - Beginning with the 2022-2023 Local Report Card**

- The school should aim to receive a rating of 3 Stars or better in all applicable Ohio Local REPORT CARD **components** on the Ohio Interactive Local Report Card (iLRC) Power User Reports, or any subsequent report enacted to replace or supplement the iLRC Power User Reports.
- A school shall be placed in Level 1 status if it does not receive a rating of 3 Stars or better in all applicable Local Report Card components. The school shall remain in Level 1 status unless it receives a rating of 3 or more Stars in all applicable Local Report Card components, at which point interventions will no longer be required, or it meets the At Risk for Closure Criteria identified below.
- At Risk for Closure Criteria:
 - Any school offering only grades K-3 or lower that receives a performance rating of 1 Star in the early literacy component of the Local Report Card OR receives an overall performance rating of 1 Star or 1.5 Stars;
 - Any school offering any combination of grades K-4 to K-8 and does not offer a grade level higher than ninth grade that receives a performance rating of 1 Star in both achievement and progress on the Local Report Card OR it receives an overall performance rating of 1 Star or 1.5 Stars and 1 Star in progress; or
 - Any school offering any grade levels between 10-12 and is not a Drop-Out Prevention and Recovery School that receives a performance rating of 1 Star in achievement and has not met annual measurable objectives for gap closing OR it receives an overall performance rating of 1 Star or 1.5 Stars and 1 Star in progress.
- When a school meets the At Risk for Closure Criteria it shall be placed in Level 2 status. A school shall progress one level of intervention for each consecutive year that it meets the At Risk for Closure Criteria. A school shall return to Level 1 status when it does not meet the

At Risk for Closure Criteria and a school shall be removed from interventions when it receives a rating of 3 or more Stars in all applicable Local Report Card components.

Level 1	
The Sponsor Will:	The School Will:
A. Offer technical assistance for the development of a plan of improvement for the school or the One Plan.	A. Require School Leader and Community School Leadership Team to attend an Ohio Leadership Advisory Council (OLAC) Facilitator Training, other approved Ohio Department of Education training, or sponsor training and implement a process to identify root-cause, needs, goals, strategies, and action steps that will move the school forward.
B. Require the School to review or revise and submit a school improvement plan for the following school year to address the academic and other needs of the School. Review and offer feedback on the school improvement plan.	B. Through a Community School Leadership Team (CSLT) that attempts to include parents, Board Members, community stakeholders and sponsor feedback, review and revise school improvement plans inclusive of 6.4 Intervention actions listed herein. Provide evidence of the process, including timelines and modification to the strategies and action steps based on data collected.
C. Require the School to monitor and evaluate the school improvement plan for the following school year to address the needs of the School.	C. The School Leader will systematically report to the Governing Authority on the development, implementation and progress of the school improvement plan at each regularly scheduled Board meeting.
D. Offer technical assistance for the development of a school professional development plan included in the school Improvement plan action steps.	D. Implement evidence-based school-wide practices to support student learning that includes “best” first instruction: <ul style="list-style-type: none"> a. Provide resources for the deconstruction of learning standards and creation of learning targets in content areas, specifically reading and math, throughout the year. Using this process systematically in TBTs, revise pacing guides in ELA and math, ensure standards and learning targets are identified in lesson plans, and evaluate the communication of the standards/learning targets to students as part of the formal OTES process/or alternative b. Align informal assessments, materials, and resources to the standards and learning targets as evidenced by the use of an alignment tool kit

	<p>c. Using disaggregated data trends to determine root cause, design and implement a multi-tiered system of supports for students at-risk that meets criteria outlined by ESSA and the Ohio Department of Education.</p>
<p>E. Offer technical assistance to support the development of instructional leadership skills for the school leader and/or the school leadership team.</p>	<p>E. Meet any other requirements as outlined in legislation or by ODE and submit any required reporting to ODE and the Sponsor as required by ESSA Focus and Priority Schools.</p> <p>F. Abide by all consequences as outlined in ESSA or any subsequent enacted legislation.</p>

Level 2 Actions	
In addition to Level 1 supports, the Sponsor Will:	The School Will:
A. Utilize school performance data and surveys to determine technical assistance needs related to improve academic instruction and student achievement.	A. The School will build upon and strengthen all Level 1 Actions.
B. Review and offer feedback on the school improvement plan and 5-Step Process. Offer training and support for School Leaders related to instructional leadership.	B. Make reasonable efforts to hire an Academic Coach(s) following Sponsor requirements and tools (See Academic Coach credentials and job responsibilities). The School will submit Academic Coach credentials to Sponsor for review and confirm hiring of an Academic Coach. The school is responsible for evidence of the fidelity to the outlined job responsibilities by the Academic Coach.
C. Establish Academic Coach minimum qualifications and suggest key roles and responsibilities.	C. Establish schedules and implement strategies that provide increased collaborative planning time for teachers that is protected from internal or external interference or interruptions.
D. Continue to offer technical assistance for the development and implementation of a school professional development plan as identified within the school improvement plan to support strategies and action steps. Utilize the guidelines outlined in Ohio Standards for Professional Development.	D. Continue and strengthen implementation of first year professional development plan components (based on root-cause analysis) outlined in the school improvement plan. Follow guidelines presented in Ohio Standards for Professional Development.
	E. Work with sponsor's school improvement team to continuously monitor progress toward academic goals listed in the school improvement plan.
	F. Using the Ohio Standards for Principals, the School will review and clarify job responsibilities and priorities for the School Leader and provide mentorship/coaching related to identified priorities and revised growth plan goals from an educational organization that will meet the needs of the school to provide coaching or mentorship. The school will provide evidence of such.
	G. School leader will develop teacher growth plans for ineffective staff following Ohio Teacher Evaluation System (OTES) guidelines or an alternative to improve academic instruction and student achievement. The school will provide evidence of such upon request.

Level 3 Actions	
In addition to Level 1 and Level 2 Supports, the Sponsor Will:	The School Will:
A. Offer technical assistance to assist in improving academic instruction and student achievement.	A. The School will build upon and strengthen all Level 1 Actions and Level 2 Actions.
B. Conduct a mini audit of the school’s instructional program, resources and tools and distribute the findings to the Governing Authority.	B. Utilizing an evidence-based evaluation model, complete a program evaluation on key reading and/or math initiatives in the school and provide results to the Governing Authority with suggestions for modification, deletions, or expansions based on the data.
	C. Based on a school review/audit from external source, implement recommendations as they relate to academic performance to address challenges and build on strengths to improve school performance in areas of leadership/governance, curriculum & instruction, data and assessment, human resource and professional development, and fiscal management.

Level 4 Actions (Risk of Academic Probation)	
If the School is not required to close by the Ohio Revised Code, the Sponsor may:	The School Will (If placed on academic probation):
A. Sponsor may take over the operations of the school; and/or	A. If the School does not close as required by the Ohio Revised Code, it will continue all Level 1, Level 2 and Level 3 Actions.
B. Work with the Board to replace the operator of the school; and/or	B. Meet all requirements as outlined by the Sponsor before the Academic Probation ² status is lifted.
C. May place the school in Academic Probation ² status and outline specific requirements for the School; and	C. Review all staff in relation to school failure and replace staff members where necessary; and/or
D. Continue to offer technical assistance towards improving academic instruction and student achievement.	D. Reconfigure the organizational structure of the school or adopt a new operational structure.
<p><i>Academic Probation status denotes that the Sponsor has considered the school's specific circumstances surrounding not meeting the minimum requirements stated in Attachment 6.4 and has prescribed steps to assist the school in meeting those requirements. The Sponsor will consider the options listed in Attachment 6.4 as possible interventions but will consider other options if deemed appropriate considering the school's specific circumstances. The Sponsor cannot be held responsible if the academic intervention steps do not result in a 3 Star rating or better in all components as the Sponsor will act in good faith to assist in ensuring the school is academically successful while honoring and respecting the School and Governing Authority's autonomy.</i></p>	

Attachment 8.3

Dismissal of Employees in the Event of Termination or Non-Renewal

In the event that the School's community school contract is terminated or non-renewed, the School may elect to treat all employees as laid-off or their positions abolished. Expiring employee contracts may be treated as non-renewed. The School may make reasonable efforts to help employees secure other appropriate positions with alternative employers and may assist employees in obtaining government benefits to which they are entitled to under law. The School will ensure that employees are timely notified of any termination or non-renewal decision.

If there is a collective bargaining agreement in effect at the time of termination or non-renewal, the layoff or other similar provisions shall be followed.

391.1 Health Insurance and Annuities

The Board provides health insurance or a payment in lieu of coverage for all full time employees. Hourly employees are not generally provided paid health insurance. The amount contributed by the Board is determined annually prior to the start of a new School year. Employees who are eligible and elect the health insurance coverage must wait thirty calendar days after the first day of work for the coverage to become effective. Employees may participate in one of three selections, based on qualifications in the School's insurance plan (subject to change per new health care laws):

1. If covered under the employee's parent's plan, the employee may choose to remain covered under that plan. There is no funding available from the school with this choice.
2. If not covered by a spouse's insurance plan, staff members will contribute 30% of major medical premiums. Additional coverages (dental, vision, life) are at the employee's election and expense.
3. If covered on a spouse's insurance plan, the School will provide \$250/month as payment in lieu of coverage (\$3,000 annualized).

From time to time the Board may have several contracts with companies who provide tax sheltered annuities to employees who wish to contribute. These are paid entirely by the employee. Employee contributions shall be made through payroll deductions. If an employee is given a leave of absence for a period of time, the Board will not pay the employee's health insurance except as required for eligible parties under the FMLA (See Policy No. 385 above). The employee may elect to pay the premiums for such time as they are on an approved leave. An employee who resigns prior to the end of their contract year will have Board paid health insurance only through the end of the month in which their resignation is effective. If a teacher or teacher aide resigns at the end of their contract year, the Board will continue to pay their health insurance premium through the month of August. Other staff members who resign at the end of their contract will have their health insurance paid through the end of the month immediately following the end of the contract.

Under federal law, employees and their dependents have the option of continuing health insurance coverage at their own expense upon the occurrence of certain qualifying events. Those events include: the death of the employee; termination of the employee (including voluntary termination and leaves of absence, but not including discharge for gross misconduct); divorce or legal separation of the covered employee from his or her spouse; the employee's becoming entitled to Medicare coverage; or cessation of dependent child coverage under the terms of the insurance policy. In the case of divorce or legal separation or cessation of dependent child coverage, you must notify the Principal or his/her designee in order for your spouse or dependents to exercise their option of continued coverage.

R.C. 9.90.

391.2 Workers' Compensation Insurance

As required by law, all employees are covered by Workers' Compensation Insurance, which may provide benefits for injuries or illness that occur as a result of employment at The Edge Academy. Any injury, regardless of its apparent seriousness must be reported immediately to your supervisor. Failure to immediately report an on the job injury will result in discipline up to and including discharge. Employees who witness an injury to a student, employee, or visitor should promptly complete a witness report.

R.C. 4123.01; R.C. 4123.83.

391.3**STRS/SERS**

By law, many Staff may be covered by the State Teachers Retirement System (STRS) or the State Public Employee Retirement System (SERS). Some contractors may not be eligible for such benefits. Determinations will be made based on law, facts and circumstances, in conjunction with applicable professional advisors and governmental agencies.

The Edge Academy will contribute 14% of each certificated staff member's salary each month to the State Teachers' Retirement System (STRS) for the benefit of the teacher's retirement plan. Each certificated teacher will contribute 11% , up to 14% in following years of his or her salary, through payroll deduction, each month for the benefit of his or her retirement plan. For non-certificated staff members, the school will contribute 14% to the State Employment Retirement System (SERS). Each non-certificated staff member will contribute 10% through payroll deduction to the SERS plan for purposes of building their retirement account.

R.C. 145.03.

FY20 - May 2020 submission
 IRN No. 133538
 Type of School: Brick and Mortar
 Contract Term: June 30, 2020

County: Summit

The Edge Academy

Statement of Receipt, Disbursements, and Changes in Fund Cash Balances
 For the Fiscal Years Ended 2017 through 2019, Actual and
 the Fiscal Years Ending 2020 through 2024, Forecasted

	Forecasted				
	Fiscal Year 2021	Fiscal Year 2022	Fiscal Year 2023	Fiscal Year 2024	Fiscal Year 2025
Operating Receipts					
State Foundation Payments (3110, 3211)	\$ 2,016,965	\$ 2,060,812	\$ 2,104,659	\$ 2,148,506	\$ 2,192,353
Charges for Services (1500)	-	-	-	-	-
Fees (1600, 1700)	-	-	-	-	-
Other (1830, 1840, 1850, 1860, 1870, 1890, 3190)	-	-	-	-	-
Total Operating Receipts	\$ 2,016,965	\$ 2,060,812	\$ 2,104,659	\$ 2,148,506	\$ 2,192,353
Operating Disbursements					
100 Salaries and Wages	\$ 1,157,557	\$ 1,180,708	\$ 1,204,322	\$ 1,228,409	\$ 1,252,977
200 Employee Retirement and Insurance Benefits	280,588	286,200	291,924	297,762	303,717
400 Purchased Services	938,759	957,535	976,874	996,793	1,017,310
500 Supplies and Materials	86,303	88,892	91,559	94,306	97,135
600 Capital Outlay - New	-	-	-	-	-
700 Capital Outlay - Replacement	-	-	-	-	-
800 Other	7,000	7,210	7,426	7,649	7,879
819 Other Debt	-	-	-	-	-
Total Operating Disbursements	\$ 2,470,207	\$ 2,520,545	\$ 2,572,105	\$ 2,624,919	\$ 2,679,018
Excess of Operating Receipts Over (Under) Operating Disbursements	\$ (453,242)	\$ (459,733)	\$ (467,446)	\$ (476,413)	\$ (486,665)
Nonoperating Receipts/(Disbursements)					
Federal Grants (all 4000 except fund 532)	\$ 439,799	\$ 444,197	\$ 448,639	\$ 453,125	\$ 457,657
State Grants (3200, except 3211)	85,599	-	-	-	-
Restricted Grants (3219, Community School Facilities Grant)	-	-	-	-	-
Donations (1820)	-	-	-	-	-
Interest Income (1400)	-	-	-	-	-
Debt Proceeds (1900)	-	-	-	-	-
Debt Principal Retirement	-	-	-	-	-
Interest and Fiscal Charges	(6,300)	(6,489)	(6,684)	(6,884)	(7,091)
Transfers - In	-	-	-	-	-
Transfers - Out	-	-	-	-	-
Total Nonoperating Revenues/(Expenses)	\$ 519,098	\$ 437,708	\$ 441,955	\$ 446,241	\$ 450,566
Excess of Operating and Nonoperating Receipts Over/(Under) Operating and Nonoperating Disbursements	\$ 65,856	\$ (22,025)	\$ (25,491)	\$ (30,172)	\$ (36,099)
Fund Cash Balance Beginning of Fiscal Year	\$ 620,214	\$ 686,070	\$ 664,045	\$ 664,045	\$ 638,556
Fund Cash Balance End of Fiscal Year	\$ 686,070	\$ 664,045	\$ 638,556	\$ 633,875	\$ 602,458

Assumptions

	Forecasted				
	Fiscal Year 2021	Fiscal Year 2022	Fiscal Year 2023	Fiscal Year 2024	Fiscal Year 2025
Staffing/Enrollment					
Total Student FTE	230	235	240	245	250
Minimum Enrollment	230	235	240	245	250
Maximum Enrollment (Building Max.)	294	294	294	294	294
Instructional Staff	26	26	26	26	26
Administrative Staff	5	5	5	5	5
Other Staff	2	2	2	2	2
Purchased Services					
Rent	\$ 312,897.00	\$ 312,897.00	\$ 312,897.00	\$ 312,897.00	\$ 312,897.00
Utilities	51,900.00	53,457.00	55,060.71	56,712.53	58,413.91
Other Facility Costs	79,500.00	81,885.00	84,341.55	86,871.80	89,477.95
Insurance	36,000.00	37,080.00	38,192.40	39,338.17	40,518.32
Management Fee	-	-	-	-	-
Sponsor Fee	58,409.00	60,161.27	61,966.11	63,825.09	65,739.84
Audit Fees	42,000.00	43,260.00	44,557.80	45,894.53	47,271.37
Contingency	-	-	-	-	-
Transportation	-	-	-	-	-
Legal	5,000.00	5,150.00	5,304.50	5,463.64	5,627.54
Marketing	5,000.00	5,150.00	5,304.50	5,463.64	5,627.54

Consulting	46,275.00	47,663.25	49,093.15	50,565.94	52,082.92
Salaries and Wages	-	-	-	-	-
Employee Benefits	-	-	-	-	-
Special Education Services	96,178.00	99,063.34	102,035.24	105,096.30	108,249.19
Technology Services	7,500.00	7,725.00	7,956.75	8,195.45	8,441.32
Food Services	169,000.00	174,070.00	179,292.10	184,670.86	190,210.99
Other	29,100.00	29,973.00	30,872.19	31,798.36	32,752.31
Total	\$ 938,759.00	\$ 957,534.86	\$ 976,874.00	\$ 996,793.31	\$ 1,017,310.19
Financial Metrics					
Debt Service Payments	\$ 6,300	\$ 6,489	\$ 6,684	\$ 6,884	\$ 7,091
Debt Service Coverage	11.45	-2.39	-2.81	-3.38	-4.09
Growth in Enrollment	3.69%	2.17%	2.13%	4.26%	4.17%
Growth in New Capital Outlay	0.00%	0.00%	0.00%	0.00%	0.00%
Growth in Operating Receipts	-0.66%	2.17%	2.13%	4.26%	4.17%
Growth in Non-Operating Receipts/Expenses	-11.40%	-15.68%	0.97%	1.95%	1.95%
Days of Cash	0.25	0.27	0.26	0.25	0.24
Total Expenditures per FTE	\$ 10,767.42	\$ 10,753.34	\$ 10,744.95	\$ 10,742.05	\$ 10,744.43

Fiscal Year 2021-2025 Projected Debt				
Description	Beginning	Principle	Interest Expense	Ending
FTE Review	\$ -	\$ -	\$ -	\$ -
Loan A	\$ -	\$ -	\$ -	\$ -
Loan B	\$ -	\$ -	\$ -	\$ -
Line of Credit	\$ -	\$ -	\$ -	\$ -
Capital Leases	\$ -	\$ -	\$ -	\$ -
Advances	\$ -	\$ -	\$ -	\$ -
Notes, Bonds	\$ -	\$ -	\$ -	\$ -
Payables (Past Due 180+ days)	\$ -	\$ -	\$ -	\$ -
Total	\$ -	\$ -	\$ -	\$ -

Assumptions Narrative Summary

The sponsor of our school is Charter School Specialist and receives a 3% fee of our State Foundation Payments. The Treasurer is Massa Financial Solutions (C. David Massa). For all non-purchased service expenses are expected to grow by 3% every year due to inflation.

Expenditure/Expense/Enrollment

Justification

Enrollment Enrollment is budgeted to increase by 8 FTE in FY21 and then by 5 FTE in FY22-24 At 250 FTE the school is capped at enrollment.
 Salaries and Wages Historically, salaries on average have grown between 2%-3% year over year. Due to this we will be utilizing a 2.0% growth factor for Salaries and Wages.
 State Foundation Payments With growth being limited and the government not increasing base funding we are not increasing state funding

Purchased Services

Rent Per an upcoming lease agreement with Charter Development, we expect no movement in our rent expense.
 Utilities Historically, utilities on average have grown between 2%-3% year over year. Due to this we will be utilizing a 3% growth factor for all utility expenses.
 Other Facility Costs We have seen an average of 1.5% increase in this expense over the past five years. We are budgeting for a 3% increase in the next five years. These expenses are Janitorial, Repairs & Maintenance, Security
 Insurance We expect insurance to increase by 3% year over year.
 Management Fee N/A
 Sponsor Fee The sponsor fee will stay steady at 3%.
 Audit Fees The school contracts with Massa Financial for Fiscal/Treasurer services and the contract is a flat yearly rate. Also, included is costs for the annual audit.
 Contingency
 Transportation Historically we have seen a 3% average increase year over year for Transportation. We expect a 3% growth factor in transportation for our forecast
 Food Service Historically, Food Service on average have grown between 2%-3% year over year. Due to this we will be utilizing a 3% growth factor for all Food Service expenses.
 Legal Historically, Legal expenses on average have grown between 2%-3% year over year. Due to this we will be utilizing a 3% growth factor for all Legal expenses.
 Marketing We will be utilizing a 3% growth factor for all marketing expenses.
 Consulting The school

Debt

Debt Status The school currently has no debt and is projecting no debt for FY20-24.

IRN No. 133538

Community School Budget

County: Summit

The Edge Academy
Budget for Fiscal Year 2021

Function	Instruction 1000	Support Services 2100-2200	Administrative Services 2300 -2400	Fiscal/Business Services 2500-2600	Operations & Maintenance 2700	Pupil Transportation 2800	Support/Food Services 2900-3100	Extracurricular Activities 4000	Facilities/ Construction Services 5000	All Other Expense 6000-7000	Total
Object	A	B	C	D	E	F	G	H	I	J	K
Salaries 100	\$ 1,060,083.00		\$ 97,474.00								\$ 1,157,557.00
Retirement Fringe Benefits 200	\$ 264,943.00		\$ 15,645.00								\$ 280,588.00
Purchased Services 400	\$ 102,178.00	\$ 47,775.00	\$ 92,509.00	\$ 83,000.00	\$ 444,297.00		\$ 169,000.00				\$ 938,759.00
Supplies 500	\$ 86,303.00										\$ 86,303.00
Capital Outlay 600											\$ -
Other 800	\$ 7,000.00			\$ 6,300.00							\$ 13,300.00
Total	\$ 1,520,507.00	\$ 47,775.00	\$ 205,628.00	\$ 89,300.00	\$ 444,297.00	\$ -	\$ 169,000.00	\$ -	\$ -	\$ -	\$ 2,476,507.00

Budget Per Pupil

Estimated Student Enrollment	230	\$6,610.90	\$207.72	\$894.03	\$388.26	\$1,931.73	\$0.00	\$734.78	\$0.00	\$0.00	\$0.00	\$10,767.42
------------------------------------	-----	------------	----------	----------	----------	------------	--------	----------	--------	--------	--------	-------------

Assumption for the Fiscal Year 2021

Expected Enrollment

Grade	K	1	2	3	4	5	6	7	8	9	10	11	12
Students	40	38	38	38	38	38	0	0	0	0	0	0	0

Expected Instructors

Grade	K	1	2	3	4	5	6	7	8	9	10	11	12
Staff	4.34	4.34	4.33	4.33	4.33	4.33	0	0	0	0	0	0	0

Expected Administrative Staff

Grade	K	1	2	3	4	5	6	7	8	9	10	11	12
Staff	0.84	0.84	0.83	0.83	0.83	0.83	0	0	0	0	0	0	0

All Other Expected Staff

Grade	K	1	2	3	4	5	6	7	8	9	10	11	12
Staff	0.34	0.34	0.33	0.33	0.33	0.33	0	0	0	0	0	0	0

Expected Purchased Services

Rent	\$ 312,897.00
Utilities	\$ 51,900.00
Other Facility Costs	\$ 79,500.00
Insurance	\$ 36,000.00
Management Fee	\$ -
Sponsor Fee	\$ 58,409.00
Audit Fees	\$ 42,000.00
Contingency	\$ -
Transportation	\$ -
Food Service	\$ -
Legal	\$ 5,000.00
Marketing	\$ 5,000.00
Consulting	\$ 46,275.00
Salaries and Wages	\$ -
Employee Benefits	\$ -
Special Education Services	\$ 96,178.00
Technology Services	\$ 7,500.00
Food Services	\$ 169,000.00
Other	\$ 29,100.00
Total	\$ 938,759.00

Fiscal Year 2021-2025 Projected Debt

Description	Beginning Year Balance	Principle Retirement	Interest Expense	Ending Year Balance	Debitor/ Creditor
FTE Review	\$ -	\$ -	\$ -	\$ -	-
Loan A	\$ -	\$ -	\$ -	\$ -	-
Loan B	\$ -	\$ -	\$ -	\$ -	-
Line of Credit	\$ -	\$ -	\$ -	\$ -	-
Notes, Bonds	\$ -	\$ -	\$ -	\$ -	-
Capital Leases	\$ -	\$ -	\$ -	\$ -	-
Payables (Past Due 180+ days)	\$ -	\$ -	\$ -	\$ -	-
Total	\$ -	\$ -	\$ -	\$ -	

Narrative Summary

Name of sponsor: Charter School Specialist/ St. Alys
 Name of management company: Accel
 Name of treasurer: Massa Financial Solutions

FY20 - October 2019 submission

IRN No. 133538

County: Summit

Type of School: Brick and Mortar

Contract Term: June 30, 2020

The Edge Academy

Statement of Receipt, Disbursements, and Changes in Fund Cash Balances

For the Fiscal Years Ended 2017 through 2019, Actual and
the Fiscal Years Ending 2020 through 2024, Forecasted

	Actual			Forecasted				
	Fiscal Year 2017	Fiscal Year 2018	Fiscal Year 2019	Fiscal Year 2020	Fiscal Year 2021	Fiscal Year 2022	Fiscal Year 2023	Fiscal Year 2024
Operating Receipts								
State Foundation Payments (3110, 3211)	\$ 1,877,605	\$ 2,000,238	\$ 2,039,962	\$ 2,084,521	\$ 2,148,333	\$ 2,169,815	\$ 2,191,514	\$ 2,213,429
Charges for Services (1500)	-	-	-	-	-	-	-	-
Fees (1600, 1700)	3,588	-	-	-	-	-	-	-
Other (1830, 1840, 1850, 1860, 1870, 1890, 3190)	15,051	787	18,756	-	-	-	-	-
Total Operating Receipts	\$ 1,896,244	\$ 2,001,025	\$ 2,058,718	\$ 2,084,521	\$ 2,148,333	\$ 2,169,815	\$ 2,191,514	\$ 2,213,429
Operating Disbursements								
100 Salaries and Wages	\$ 1,350,858	\$ 1,253,398	\$ 1,336,057	\$ 1,167,346	\$ 1,190,693	\$ 1,214,507	\$ 1,238,797	\$ 1,263,573
200 Employee Retirement and Insurance Benefits	185,589	275,414	268,248	267,055	272,396	277,844	283,401	289,069
400 Purchased Services	610,493	721,414	895,073	934,530	953,179	972,387	992,172	1,012,550
500 Supplies and Materials	277,515	215,218	98,658	153,916	158,533	163,289	168,188	173,234
600 Capital Outlay -New	-	10,938	-	-	-	-	-	-
700 Capital Outlay - Replacement	-	-	-	-	-	-	-	-
800 Other	51,750	54,828	1,150	1,500	1,500	1,545	1,591	1,639
819 Other Debt	-	-	-	-	-	-	-	-
Total Operating Disbursements	\$ 2,476,205	\$ 2,531,211	\$ 2,599,187	\$ 2,524,346	\$ 2,576,302	\$ 2,629,573	\$ 2,684,149	\$ 2,740,065
Excess of Operating Receipts Over (Under) Operating Disbursements	\$ (579,961)	\$ (530,186)	\$ (540,469)	\$ (439,825)	\$ (427,970)	\$ (459,758)	\$ (492,635)	\$ (526,636)
Nonoperating Receipts/(Disbursements)								
Federal Grants (all 4000 except fund 532)	\$ 265,714	\$ 386,043	\$ 428,144	\$ 416,494	\$ 420,659	\$ 424,866	\$ 429,114	\$ 433,405
State Grants (3200, except 3211)	207,980	273,030	-	-	-	-	-	-
Restricted Grants (3219, Community School Facilities Grant)	-	-	-	-	-	-	-	-
Donations (1820)	-	-	-	30,000	30,000	30,000	30,000	30,000
Interest Income (1400)	195	130	-	-	-	-	-	-
Debt Proceeds (1900)	-	-	-	-	-	-	-	-
Debt Principal Retirement	-	-	-	-	-	-	-	-
Interest and Fiscal Charges	12	-	(5,540)	(5,700)	(5,871)	(6,047)	(6,229)	(6,415)
Transfers - In	-	-	-	-	-	-	-	-
Transfers - Out	-	-	-	-	-	-	-	-
Total Nonoperating Revenues/(Expenses)	\$ 473,901	\$ 659,203	\$ 422,604	\$ 440,794	\$ 444,788	\$ 448,818	\$ 452,886	\$ 456,990
Excess of Operating and Nonoperating Receipts Over/(Under) Operating and Nonoperating Disbursements	\$ (106,060)	\$ 129,017	\$ (117,864)	\$ 969	\$ 16,818	\$ (10,939)	\$ (39,750)	\$ (69,646)
Fund Cash Balance Beginning of Fiscal Year	\$ 304,775	\$ 198,715	\$ 327,732	\$ 209,867	\$ 210,837	\$ 227,655	\$ 216,716	\$ 176,967
Fund Cash Balance End of Fiscal Year	\$ 198,715	\$ 327,732	\$ 209,867	\$ 210,837	\$ 227,655	\$ 216,716	\$ 176,967	\$ 107,323

Assumptions

	Actual			Forecasted				
	Fiscal Year 2017	Fiscal Year 2018	Fiscal Year 2019	Fiscal Year 2020	Fiscal Year 2021	Fiscal Year 2022	Fiscal Year 2023	Fiscal Year 2024
Staffing/Enrollment								
Total Student FTE	248	242	239	245	250	250	250	250
Minimum Enrollment					240	240	240	240
Maximum Enrollment (Building Max)					294	294	294	294
Instructional Staff	24	25	25	25	26	26	26	26
Administrative Staff	6	6	5	5	5	5	5	5
Other Staff	0	0	2	2	2	2	2	2
Purchased Services								
Rent	\$ 312,897	\$ 312,897	\$ 312,897	\$ 312,897	\$ 312,897	\$ 312,897	\$ 312,897	\$ 312,897
Utilities	\$ 46,947	\$ 53,320	\$ 67,627	\$ 51,900	\$ 53,457	\$ 55,061	\$ 56,713	\$ 58,414
Other Facility Costs	\$ 38,034	\$ 36,485	\$ 82,427	\$ 101,040	\$ 104,071	\$ 107,193	\$ 110,409	\$ 113,721
Insurance	\$ 29,562	\$ 37,084	\$ 24,925	\$ 24,940	\$ 25,688	\$ 26,459	\$ 27,253	\$ 28,070
Management Fee	\$ -	\$ -	\$ -	\$ -	\$ -	\$ -	\$ -	\$ -
Sponsor Fee	\$ 57,136	\$ 54,395	\$ 58,433	\$ 60,696	\$ 62,517	\$ 64,392	\$ 66,324	\$ 68,314
Audit Fees	\$ -	\$ -	\$ 40,871	\$ 44,000	\$ 45,320	\$ 46,680	\$ 48,080	\$ 49,522
Contingency	\$ -	\$ -	\$ -	\$ -	\$ -	\$ -	\$ -	\$ -
Transportation	\$ 5,642	\$ 2,508	\$ 3,019	\$ 2,700	\$ 2,781	\$ 2,864	\$ 2,950	\$ 3,039
Legal	\$ 9,321	\$ 4,575	\$ 8,604	\$ 6,900	\$ 7,107	\$ 7,320	\$ 7,540	\$ 7,766
Marketing	\$ -	\$ 147	\$ 7,960	\$ 17,600	\$ 18,128	\$ 18,672	\$ 19,232	\$ 19,809
Consulting	\$ -	\$ -	\$ 21,838	\$ 16,407	\$ 16,899	\$ 17,406	\$ 17,928	\$ 18,466
Salaries and Wages	\$ -	\$ -	\$ -	\$ -	\$ -	\$ -	\$ -	\$ -
Employee Benefits	\$ -	\$ -	\$ -	\$ -	\$ -	\$ -	\$ -	\$ -
Special Education Services	\$ -	\$ -	\$ 80,553	\$ 69,600	\$ 71,688	\$ 73,839	\$ 76,054	\$ 78,335
Technology Services	\$ -	\$ -	\$ 4,856	\$ 4,350	\$ 4,481	\$ 4,615	\$ 4,753	\$ 4,896
Food Services	\$ 165,105	\$ 164,658	\$ 161,038	\$ 199,000	\$ 204,970	\$ 211,119	\$ 217,453	\$ 223,976
Other	\$ -	\$ -	\$ 20,024	\$ 22,500	\$ 23,175	\$ 23,870	\$ 24,586	\$ 25,324
Total	\$ 664,644	\$ 666,069	\$ 895,073	\$ 934,530	\$ 953,179	\$ 972,387	\$ 992,172	\$ 1,012,550
Financial Metrics								
Debt Service Payments	\$ (12)	\$ -	\$ 5,540	\$ 5,700	\$ 5,871	\$ 6,047	\$ 6,229	\$ 6,415
Debt Service Coverage	8839.33	0.00	-20.28	1.17	3.86	-0.81	-5.38	-9.86
Growth in Enrollment	-8.82%	-2.42%	-1.24%	2.51%	2.04%	0.00%	0.00%	0.00%
Growth in New Capital Outlay	0.00%	0.00%	-100.00%	0.00%	0.00%	0.00%	0.00%	0.00%
Growth in Operating Receipts	-14.51%	5.53%	2.88%	1.25%	3.06%	1.00%	1.00%	1.00%
Growth in Non-Operating Receipts/Expenses	1.08%	39.10%	-35.89%	4.30%	0.91%	0.91%	0.91%	0.91%
Days of Cash	0.12	0.08	0.13	0.08	0.08	0.09	0.08	0.06
Total Expenditures per FTE	\$ 9,984.65	\$ 10,459.55	\$ 10,898.44	\$ 10,326.72	\$ 10,328.69	\$ 10,542.48	\$ 10,761.51	\$ 10,985.92

Fiscal Year 2019-2023 Projected Debt				
Beginning	Principle	Interest Expense	Ending	Debitor/
\$ -	\$ -	\$ -	\$ -	
\$ -	\$ -	\$ -	\$ -	
\$ -	\$ -	\$ -	\$ -	
\$ -	\$ -	\$ -	\$ -	
\$ -	\$ -	\$ -	\$ -	
\$ -	\$ -	\$ -	\$ -	
\$ -	\$ -	\$ -	\$ -	
\$ -	\$ -	\$ -	\$ -	
\$ -	\$ -	\$ -	\$ -	
\$ -	\$ -	\$ -	\$ -	
\$ -	\$ -	\$ -	\$ -	
\$ -	\$ -	\$ -	\$ -	
\$ -	\$ -	\$ -	\$ -	
\$ -	\$ -	\$ -	\$ -	

Assumptions Narrative Summary

The sponsor of our school is Charter School Specialist and receives a 3% fee of our State Foundation Payments. The Treasurer is Massa Financial Solutions (C. David Massa). For all non-purchased service expenses are expected to grow by 3% every year due to inflation.

Expenditure/Expense/Enrollment

Justification

- Enrollment Enrollment is budgeted to increase by 6 FTE in FY20 and then by 5 FTE in FY21 At 250 FTE the school is capped at enrollment.
- Salaries and Wages Historically, salaries on average have grown between 2%-3% year over year. Due to this we will be utilizing a 2.0% growth factor for Salaries and Wages.
- State Foundation Payments With growth being limited we are projecting state aid to increase by 1% year over year

Purchased Services

- Rent Per an upcoming lease agreement with Charter Development, we expect no movement in our rent expense.
- Utilities Historically, utilities on average have grown between 2%-3% year over year. Due to this we will be utilizing a 3% growth factor for all utility expenses.
- Other Facility Costs We have seen an average of 1.5% increase in this expense over the past five years. We are budgeting for a 3% increase in the next five years. These expenses are Janitorial, Repairs & Maintenance, Security
- Insurance We expect insurance to increase by 3% year over year.
- Management Fee N/A
- Sponsor Fee The sponsor fee will stay steady at 3%.
- Audit Fees The school contracts with Massa Financial for Fiscal/Treasurer services and the contract is a flat yearly rate. Also, included is costs for the annual audit.
- Contingency
- Transportation Historically we have seen a 3% average increase year over year for Transportation. We expect a 3% growth factor in transportation for our forecast
- Food Service Historically, Food Service on average have grown between 2%-3% year over year. Due to this we will be utilizing a 3% growth factor for all Food Service expenses.
- Legal Historically, Legal expenses on average have grown between 2%-3% year over year. Due to this we will be utilizing a 3% growth factor for all Legal expenses.
- Marketing We will be utilizing a 3% growth factor for all marketing expenses.
- Consulting The school contracts with various vendors on an as needed basis for third party consulting services
- Debt Status The school currently has no debt and is projecting no debt for FY19-23.

Debt